












# Product Range 2009



-  **Low voltage current transformers**
-  for industrial applications
-  for tariff applications
-  **Bus bar isolators/ -supports**
-  **Voltage transformers**
-  **Measuring transducers**
-  **Energy meters**
-  for industrial applications
-  for tariff applications



# CERTIFICATE

The TÜV CERT Certification Body  
of TÜV SÜD Management Service GmbH  
certifies in accordance  
with TÜV CERT procedures that

**MBS Sulzbach Messwandler GmbH**  
Eisbachstraße 51  
D-74429 Sulzbach-Laufen

has established and applies  
a Quality Management System for

Development, production and sales of measuring transducers,  
mercury meters, bus bar insulators/ holders,  
Low voltage current transformers series 0.5-split core current transformers,  
verification/ certification of electrical measuring instruments  
within the scope of the Official Testing Laboratory for Measuring Instruments.

An audit was performed, Report No. **70003062**  
Proof has been furnished that the requirements  
according to

**ISO 9001: 2000**

are fulfilled. The certificate is valid until **2009-05-01**  
Certificate Registration No. **12 100 20346**



*M. Wogel*

TÜV CERT Certification Body  
of TÜV SÜD Management Service GmbH  
Hofersstraße 65  
D-80333 München

Munich, 2006-05-17

00000000

## Type Approval Certificate



This is to certify that the undernoted product(s) has/have been tested in accordance with  
the relevant requirements of the GL Type Approval System.

Certificate No.	12 246 - 98 HH
Company	MBS AG Eisbachstraße 51 74429 Sulzbach-Laufen, GERMANY
Product Description	Low Voltage Current Transformer Plug In Type
Type	ASR 20.3, 201.3, 21.x, 22.3; ASK 21.3, 31.x, 41.x, 51.x, 61.x, 83.x, 81.4, 101.4, 103.3, 105.6, 123.3, 205.3, 231.5, 318.3, 412.4, 421.4, 541.4, 561.4
Environmental Category	C
Technical Data / Range of Application	Highest voltage for equipment : 720 V AC Rated frequency : 50 / 60 Hz Primary current I <sub>pn</sub> : 30 A up to 4000 A Secondary current I <sub>sn</sub> : 5 A or 1 A Rated short-time current I <sub>sh</sub> : 60 x I <sub>pn</sub> Accuracy class : 0.5 or 1 Primary conductor: 20 x 10 mm up to 100 x 10 mm, 2 x 20 x 10 mm up to 3 x 100 x 10 mm or 17.5 mm up to 100 mm round conductor ---x : transformers in different front-to-back sizes
Test Standard	Details according to MBS catalog Guidelines for the Performance of Type Approvals, Chapter 2, Edition 2003 IEC 185:1967 + A1:1990, DIN VDE 0414 Part 1:1994-01
Documents	Test report :IPH Berlin, Typprüfbericht Nr. 469.279.6.402 and Nr.469.593.5.323 RMS-Prüfbericht Nr. 3-03/98 and Nr. 2-06/98 Catalog MBS 1998
Remarks	None
Valid until	2013-10-16
Page	1 of 1
File No.	I.J.05
Hamburg, 2008-10-17	

Type Approval Symbol

*H. A. Tobaben*  
Heinz Tobaben

*Thomas Reimer*  
Thomas Reimer

Germanischer Lloyd

This certificate is issued on the basis of "Guidelines for the Performance of Type Approvals Part 1, Procedure"



**Dear Customer,**

realizing today, on what is apparent to others only tomorrow represents a part of the success of **MBS AG.**

We proudly present in our new catalogue our fullest product range of low voltage current transformers for industrial and tariff applications as well as our voltage transformers, measuring transducers, energy meters, and bus bar isolators and bus bar supports.

The name of MBS is symbolic for innovation and know-how "Made in Germany". For more than 30 years, our world-wide customers are taking advantage of our vast selection of product availability combined with our highest standard of quality. Our numerous international certificates and licences are mirroring MBS's standard.

Our one to one consultation is readily available to you when searching together for solutions to your requirements whilst maintaining the highest standard quality of supply according to DIN EN ISO 9001.

My colleagues and I are looking forward to working with you.

Please take advantage of our short delivery times and optimal solutions.

**MBS AG** guarantees your success.

Yours,

A handwritten signature in blue ink that reads "W. Gilgen". The signature is fluid and cursive.

Wolfgang Gilgen  
Prof. Dr. h.c.

**MBS AG****‘Sulzbach Messwandler’****Eisbachstraße 51****74429 Sulzbach-Laufen****Germany****Tel.: +49 7976 9851-0****Fax: +49 7976 9851-90****E-mail: [info@mbs-ag.com](mailto:info@mbs-ag.com)****[www.mbs-ag.com](http://www.mbs-ag.com)**

The descriptions in this catalogue are not binding.

We are not liable for any printing mistakes.

With the publication of this catalogue, any previously issued information is rendered invalid.

## Contents

About us	4
MBS distributors	9
MBS product groups summarized	12
Type annotation of MBS current transformers	14
MBS current transformers summarized	16
Current transformers – Technical characteristics	22
<b>Low voltage current transformers for industrial applications</b>	<b>29</b>
Tube current transformers	29/30
Tube current transformers, resin hardened	37
Tube current transformers for panel boards	39
Plug-in current transformers	40
Wound current transformers	99
Split core current transformers	109
Summation current transformers	113
NH-current transformers for fuse rails	119
Protection tube current transformers	125
Protection plug-in current transformers	128
Three-phase current transformer sets	157
<b>Low voltage current transformers for tariff applications</b>	<b>167</b>
Tube current transformers	167/168
Plug-in current transformers	167/170
Wound current transformers	195/196
Summation current transformers	195/197
Three-phase current transformers sets	199
<b>Accessories for low voltage current transformers</b>	<b>205</b>
Snap-on mountings	206
Copper tubes, mounting angles	206
Mounting kits, secondary caps	207
Locking pistons	207
Sealed shutters	207
Copper bus bars	208
<b>Bus bar isolators</b>	<b>211/212</b>
<b>Bus bar supports</b>	<b>211/216</b>
<b>Additional products</b>	<b>223</b>
Shunts	225
Amperemeters change-over switch	230
NEOZED fuse base, contact tongue	230
<b>Voltage transformers for low voltage</b>	<b>231</b>
1-pole isolated, 2-pole isolated	232
<b>Measuring transducers</b>	<b>237</b>
SWMU	238
NMC	241
FASK	244
EMBSIN	246
Order list	271
<b>Electronic energy meters for industrial applications</b>	<b>293</b>
Single-phase energy meters, direct measuring	294
Three-phase energy meters, direct measuring	300
Three-phase energy current transformer meters	306
Three-phase energy current transformer meters, front mounted 96 x 96 mm	315
<b>Electro-mechanical energy meters for industrial applications</b>	<b>319</b>
<b>Electronic energy meters for tariff applications (calibrated)</b>	<b>321</b>
Single-phase energy meters, direct measuring	322
Three-phase energy meters, direct measuring	325
Three-phase energy current transformer meters	338
Electro-mechanical energy meters for tariff applications	351

## About us

The Zähleranstalt Rudolf Köhler (ZARK), founded in the year 1925, was instrumental in the inauguration during 1977 through Wolfgang Gilgen, managing director and owner, in the today's very successful organization MBS Sulzbach Messwandler GmbH.

Further business involvement and investments follow at home and abroad.

**1977**



MBS is located in Baden-Württemberg, in the vicinity of Stuttgart. The organization is known very soon for the superior performance of its products, its great innovative strength, and the continuous growth of the business. MBS produces initially only a limited number of current transformers. Measuring performances, innovations, and maximal product reliability lead in a short time to obtain a greater, and growing share of the market.

**1985**

Since 1985 MBS represents „Staatlich anerkannte Prüfstelle für Messgeräte für Elektrizität EA90“ (a National testing institute for measuring instruments for electricity). This accolade was only bestowed on MBS for their continued optimal performance on measuring reliability and user friendly safety of their products.



**1987**



The first works in Sulzbach-Laufen soon reaches its capacity limit due to the marketing success, increasing sales and an ever expanding product range. MBS is compelled to enlarge their production and storage facilities. A second works is created which is adapted to cater for further eventualities.

**1995**

MBS receives the **quality certificate „DIN EN ISO 9001“** issued by TÜV Mannheim. This distinction opens the door for the worldwide activities. Already in this year MBS is exporting to more than 20 countries.



**1997**

The worldwide activities of MBS Sulzbach Messwandler GmbH are a challenge for the company administration. An architecturally challenging as well as highly functional multipurpose building is completed in the Eisbachstraße 51. Today, we find here the headquarters of the MBS group of companies.

Production and warehouse facilities are not confined just to Sulzbach-Laufen, but also extend to a neighbouring town. In Slovenia MBS MT is born to produce the cores for our current transformers.

**1998**

We receive the **„GL Type Approval Certificate“** from Germanischer Lloyd.

**2000**

MBS views the future optimistically and will consider at all times the implementation of new challenges. A fully automated production line for metal and synthetic materials is installed. Due to the constant growth in the demand for measuring transducers only the best state-of-the-art technology is acquired and implemented.



**2004**

The expansion of the product range as well as the custom made units contribute further to the sales successes.

To satisfy the demands of our customers, it is necessary to increase the production capacity. At the same time, costs in manufacturing had to be reduced. With these tasks in mind a new modern storage and logistic center is introduced at the main factory in Sulzbach-Laufen.

**2005**

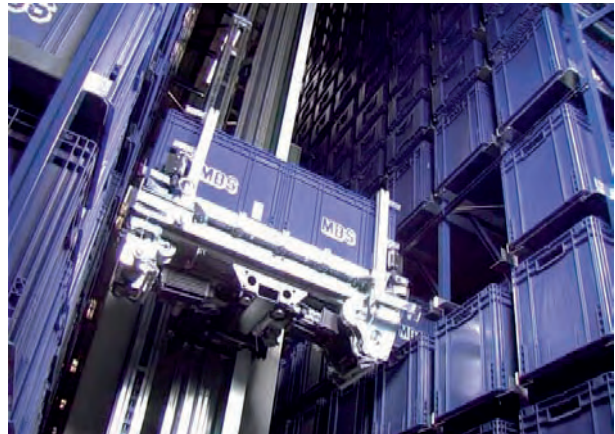
MBS again increase substantially their turnover. More and more customers believe in the product and acknowledge the high quality and professionalism of MBS.

A subsidiary is established in North Rhine-Westphalia, as well as offices in London „MBS Sulzbach Messwandler Limited“ and in Slovenia „MBS-CT d.o.o.“.

## 2006

A further expansion is being implemented for the mechanical production of synthetic materials and enlargement of the product range.

Another two-storey building is purchased complete with offices and facilities for the production of cores for the current transformers. This manufacturing site is equipped with machinery for steel band cutting of all sizes, core winding machines, core heating furnaces as well as overhead mobile cranes for transporting heavy loads.



## 2007

MBS AG is born.

A subsidiary is established in northern Germany to serve northern Europe.

Very senior engineers are employed in management to meet the ever increasing work load.

At our three production centres, situated in the Federal Republic of Germany, on an area spanning more than 12,000 m<sup>2</sup>, 4,700 transformers „Made in Europe“ are being built per day, locally to 100 % in Baden-Württemberg, in multi-shift operation.

More than 20.000 products are supplied to all continents.

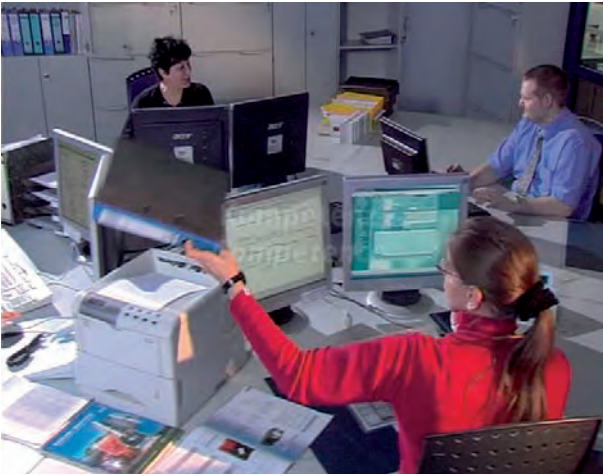


## 2009

Further current transformers were integrated in our already extensive range which we have developed in cooperation with industries known worldwide.



## Our expectations for the future



An extremely long list of orders making full use of our production capacity, ensures that we can look into a successful future.

We expect an increase in customers as well as distributors. We have to be prepared and not lose-out at what we have created.

The foundation is in place and improvements are begin. The tools for refinements are in place. An important focus is to keep our administrative staff fully informed of up-to-date computer technology, which is only one of many tasks.

Realizing today, on what others think only tomorrow is our motto. More engagement, more service, and more customer satisfaction, are at all times the goals of MBS.


The management and all employees are highly motivated, as well as customer oriented, and know the importance of service, quality responses, innovation and assisting the customer by providing the shortest delivery times whenever possible. This can only be achieved by means of hand-in-glove cooperation between the various departments. These efforts are clearly reflected in our customers in the home and export markets as well as our continuously growing customer base consisting of well-known international organizations covering industry and energy supply companies. We are proud of the results of our hands-on activities. However, the past whilst very encouraging is now consigned to history.

Please visit our **MBS homepage:**  
[www.mbs-ag.com](http://www.mbs-ag.com)





## Headquarters

 **MBS AG**  
'Sulzbach Messwandler'  
Eisbachstraße 51  
74429 Sulzbach-Laufen  
Germany  
Tel.: +49 7976 9851-0  
Fax: +49 7976 9851-90  
E-mail: info@mbs-ag.com

**Works 2:**  
Eisbachstraße 33  
74429 Sulzbach-Laufen  
Germany

**Works 3:**  
BWS GmbH & Co. KG  
Eugen-Hahn-Straße 35  
73565 Spraitbach  
Germany

**MBS AG**  
'Sulzbach Messwandler'  
Northern Europe  
Am Seedeich 31-32  
27472 Cuxhaven  
Germany  
Tel.: +49 4721 399039  
Fax: +49 4721 399047  
E-mail: info@mbs-ag.com

 **MBS Sulzbach Messwandler Ltd**  
Hans Gerlach  
P.O.Box 31635, London W11 3WF  
England  
Tel.: +44 20 77273254  
Fax: +44 20 72219445  
E-mail: Mbshans@aol.com

**Domestic**
**Baden-Württemberg**
**Baden**

Henry Wollschläger  
 Industrievertretung-Elektrotechnik  
 Seckacher Str. 158  
 68259 Mannheim  
 Tel.: +49 621 7140-427  
 Fax: +49 621 7140-527  
 E-mail:  
 buerowollschlaeger@t-online.de

**Württemberg**

MDB Blechschmidt  
 Weißer Weg 30  
 74417 Gschwend  
 Tel.: +49 7972 72066  
 Fax: +49 7972 6398  
 E-mail:  
 mdb@mdb-blechschmidt.de

**Bayern**
**Franken, Niederbayern, Oberpfalz**

Ing.-Büro Beyer  
 Elektroingenieurbüro  
 Hauptstr. 33  
 91094 Langensendelbach  
 Tel.: +49 9133 5983  
 Fax: +49 9133 9877  
 E-mail: info@ibbeyer.de

**Südbayern**

Ing. Adolf Müller GmbH  
 Industrievertretungen  
 Elly-Staegmeyer-Straße 15  
 80999 München  
 Tel.: +49 89 8126-044  
 Fax: +49 89 8126-925  
 E-mail: info@ingam.de

**Berlin**

Ingenieurbüro  
 Günter Hentschel  
 Paul-Lincke-Ufer 39/40  
 10999 Berlin  
 Tel.: +49 30 617895-0  
 Fax: +49 30 617895-11  
 E-mail: info@hentschel-vertrieb.de

**Brandenburg**

Ingenieurbüro  
 Günter Hentschel  
 Paul-Lincke-Ufer 39/40  
 10999 Berlin  
 Tel.: +49 30 617895-0  
 Fax: +49 30 617895-11  
 E-mail: info@hentschel-vertrieb.de

**Bremen**

Ingenieurbüro Breuell  
 Techn. Vertretungen GmbH  
 Grützmühlenweg 40  
 22339 Hamburg  
 Tel.: +49 40 538092-10  
 Fax: +49 40 538092-85  
 E-mail: info@breuell.de

**Hamburg**

Ingenieurbüro Breuell  
 Techn. Vertretungen GmbH  
 Grützmühlenweg 40  
 22339 Hamburg  
 Tel.: +49 40 538092-10  
 Fax: +49 40 538092-85  
 E-mail: info@breuell.de

**Hessen**

H.-J. Ehrlich KG  
 Automation + Energietechnik  
 Kurmainzer Str.45  
 65929 Frankfurt/Main  
 Tel.: +49 69 860066-0  
 Fax: +49 69 860066-30  
 E-mail: info@ehrlich-kg.de

**Mecklenburg-Vorpommern**

Ingenieurbüro Breuell  
 Techn. Vertretungen GmbH  
 Grützmühlenweg 40  
 22339 Hamburg  
 Tel.: +49 40 538092-10  
 Fax: +49 40 538092-85  
 E-mail: info@breuell.de

**Niedersachsen**

Fritsche Industrievertretungen  
 GmbH  
 Großhorst 15  
 30916 Isernhagen  
 Tel.: +49 5136 8893-0  
 Fax: +49 5136 8893-20  
 E-mail: info@fritschegmbh.de

**Nordrhein-Westfalen**

A + H  
 Vertriebsgesellschaft für Geräte  
 der Steuer- und Regeltechnik mbH  
 & Co. KG  
 Borner Str. 31  
 42897 Remscheid  
 Tel.: +49 2191 9376-0  
 Fax: +49 2191 9376-76  
 E-mail: info@auh-vertrieb.de

**Saarland**

Henry Wollschläger  
 Industrievertretung-Elektrotechnik  
 Seckacher Str. 158  
 68259 Mannheim  
 Tel.: +49 621 7140-427  
 Fax: +49 621 7140-527  
 E-mail:  
 buerowollschlaeger@t-online.de

Bereich: EVU  
 KDK Dornscheidt GmbH  
 Gewerbegebiet Oberpleis  
 In der Brückenwiese 7  
 53639 Königswinter  
 Tel.: +49 2244 91994-0  
 Fax: +49 2244 91994-14  
 E-mail: info@kdk-dornscheidt.com

**Rheinland-Pfalz**

Henry Wollschläger  
 Industrievertretung-Elektrotechnik  
 Seckacher Str. 158  
 68259 Mannheim  
 Tel.: +49 621 7140-427  
 Fax: +49 621 7140-527  
 E-mail:  
 buerowollschlaeger@t-online.de

H.-J. Ehrlich KG  
 Automation + Energietechnik  
 Kurmainzer Str.45  
 65929 Frankfurt/Main  
 Tel.: +49 69 860066-0  
 Fax: +49 69 860066-30  
 E-mail: info@ehrlich-kg.de

**Sachsen**

TML GmbH  
 Industrievertretungen  
 Mommsenstr. 2  
 04329 Leipzig  
 Tel.: +49 341 252449-0  
 Fax: +49 341 252449-19  
 E-mail: info@tml-gmbh.de

**Sachsen-Anhalt**

TML GmbH  
 Industrievertretungen  
 Mommsenstr. 2  
 04329 Leipzig  
 Tel.: +49 341 252449-0  
 Fax: +49 341 252449-19  
 E-mail: info@tml-gmbh.de

**Schleswig-Holstein**

Ingenieurbüro Breuell  
 Techn. Vertretungen GmbH  
 Grützmühlenweg 40  
 22339 Hamburg  
 Tel.: +49 40 538092-10  
 Fax: +49 40 538092-85  
 E-mail: info@breuell.de

**Thüringen**

Industrievertretung  
 Gebr. Göritz GmbH  
 Feldstr. 1  
 99334 Ichtershausen  
 Tel.: +49 3628 62917-0  
 Fax: +49 3628 640284  
 E-mail: Gebr.Goeritz@gmx.de






## Europe

 **Austria**  
Fischmeister Handelsges. mbH  
Herzogstr. 58  
4060 Leonding  
Tel.: +43 70 651642-0  
Fax: +43 70 651642-20  
E-mail: office@fischmeister.at

 **Belgium**  
Verdoolaeye NV  
Meet- en regeltechniek  
Noorderlaan 117  
2030 Antwerpen  
Tel.: +32 35 411111  
Fax: +32 35 410635  
E-mail: info@verdoolaeye.be


 **Bulgaria**  
GTT Engineering Ltd.  
10 Yuriy Venelin str.  
9004 Varna  
Tel.: +359 52 636728  
Fax: +359 52 602393  
E-mail: office@gtt-eng.net


 **Czech Republic**  
GHV Trading spol.s r.o  
Kounicova 67a  
602 00 Brno  
Tel: +420 541 2355-32, -33, -34  
Fax: +420 541 235387  
E-mail: ghv@ghvtrading.cz

 **Croatia**  
Tomas & Co.  
Kopilica 9  
21000 Split  
Tel.: +385 21 490643  
Fax: +385 21 490642  
E-mail: tomas-co@st.t-com.hr

 **Denmark**  
DEIF A/S  
Frisenborgvej 33  
7800 Skive  
Tel.: +45 9614 9614  
Fax: +45 9614 9615  
E-mail: deif@deif.com

 **Estonia**  
Klinkmann Eesti As  
Mehaanika 2 B  
10602 Tallinn  
Tel.: +372 668 4500  
Fax: +372 668 4501  
E-mail:  
klinkmann.est@klinkmann.ee

 **Finland**  
Sähkölehto OY  
Holkkitie 14  
00880 Helsinki  
Tel.: +358 97 746420  
Fax: +358 97 591071  
E-mail: office@sahkolehto.fi

 **Greece**  
OY KLINKMANN  
P.O.Box 38  
00371 Helsinki  
Tel.: +358 9 540 4940  
Fax: +358 9 541 3541  
E-mail: automation@klinkmann.fi

 **Greece**  
2KAPPA LTD  
Sofokli Venizelou 13  
54628 Menemeni Thessaloniki  
Tel.: +30 2310 775510-13  
Fax: +30 2310 775514-15  
E-mail: 2kappa@pel.forthnet.gr

**VIMKA Ltd**  
Neoktista Aspropyrgou  
19300 Aspropyrgos Attikis/Athens  
Tel.: +30 210 5590870, 5590759  
Fax: +30 210 5590832  
E-mail: vimka@internet.gr

 **Hungary**  
Duvalex BT für Handel +  
Dienstleistungen  
Szárny u. 6  
1173 Budapest  
Tel.: +36 12 572217  
Fax: +36 12 572217  
E-mail: duvalex@mail.externet.hu


**0,4 KV Kereskedelmi Kft.**  
Táblás utca 39  
1097 Budapest  
Tel.: +36 12 811850  
Fax: +36 12 811851  
E-mail: 04kv@04kv.hu

 **Latvia**  
Klinkmann Lat Ltd.  
Ganib dambis 2a  
1045 Riga  
Tel.: +371 738 1617  
Fax: +371 738 2451  
E-mail: klinkmann@klinkmann.lv

 **Lithuania**  
UAB Klinkmann Lit  
Smolensko str. 10  
03201 Vilnius  
Tel.: +370 5 215 1646  
Fax: +370 5 216 2641  
E-mail: post@klinkmann.lt

**UAB Klinkmann Lit**  
Kauno str. 21A  
91558 Klaipeda  
Tel.: +370 46 310 850  
Fax: +370 46 310 850  
E-mail: post@klinkmann.lt


 **Norway**  
DEIF Norge AS  
Døveveien 41  
3170 Sem  
Tel.: +47 3338 1600  
Fax: +47 3338 1601  
E-mail: norge@deif.com

 **Poland**  
ASTAT sp. z o.o.  
ul. Dabrowskiego 441  
60-451 Poznan  
Tel.: +48 61 8488871  
Fax: +48 61 8488276  
E-mail: info@astat.com.pl

 **Portugal**  
SISTEMAS DE  
AUTOMAÇÃO E CONTROLO, LDA  
Rua Álvaro Ferreira Alves, 56-C  
Zona Industrial Santa Marta do  
Pinhal  
2855-591 Corroios  
Tel.: +351 21 2549280  
Fax: +351 21 2549288  
E-mail: sparra@sisacol.com

 **Romania**  
Business for Business  
Str Gara Herastrau nr. 4 - Etaj. IV  
Bucharest-Sector 2  
020334 Bucharest  
Tel.: +40 21 2329502, 2329503  
Fax: +40 21 2329294  
E-mail: office@dcb.ro

**COELCO TRADE**  
Autostrada Bucuresti-Pitesti, Km  
13.5  
Parcul Industrial "Polo  
Occidentale", Hall M  
Bucharest  
Tel.: +40 21 3100961/62  
Fax: +40 21 3100989  
E-mail: office@coelco.ro

 **Russia**  
East-West Consulting  
Am Alten Berg 7  
97996 Niederstetten  
Tel.: +49 7932 606456  
Fax: +49 7932 606458  
E-mail:  
mbs@easteuropeconsulting.com

ELECTROMASHHOLDING Ltd.  
Verhnjaja Krasnoselskaja 2  
Moscow, 107140  
Tel.: +7 495 9805516  
Fax: +7 495 9806409  
E-mail: aglu@elmash-holding.ru

ETK Joule GmbH  
Elektrodnaja Strasse, Haus 2,  
Bl. 12-14  
Moscow, 111141  
Tel.: +7 495 3631867  
Fax: +7 495 3631867  
E-mail: mail@joule.ru

 **Serbia**  
INTERTEHNIK TRADE doo  
Nebojsina 26  
11000 Belgrade  
Tel.: +381 11 2441536  
Tel.: +381 11 3835148  
Fax: +381 11 2433370  
E-mail: vkricka@intertehnik.co.rs


 **Slovenia**  
TDR Trading d.o.o.  
Ul. 10. oktobra 9  
2000 Maribor  
Tel.: +386 22 294650  
Fax: +386 22 522401  
E-mail: info@tdr-trading.si

 **Sweden**  
Beving Elektronik AB  
Box 93  
127 22 Skärholmen  
Tel.: +46 8680 1199  
Fax: +46 8680 1188  
E-mail: info@bevingelektronik.se

 **Switzerland**  
**Liechtenstein**  
WISAR Wyser + Anliker AG  
Steinackerstraße 29  
8302 Kloten  
Tel.: +41 44 81522 33  
Fax: +41 44 81522 60  
E-mail: info@wisar.ch

 **The Netherlands**  
Controlin BV  
Glasblazerstraat 1  
2984 BL Ridderkerk  
Tel.: +31 180 330522  
Fax: +31 180 330529  
E-mail: sales@controlin.nl

 **Turkey**  
ELEKTRA  
ELEKTRONIK SANAYI VE TICARET  
LTD. ŞTİ.  
SAN-BİR Boulevard 4.Region 8.Street  
No:70  
34500 Çakmaklı/ Büyükçekmece/  
Istanbul  
Tel.: +90 212 886 20 80  
Fax: +90 212 886 97 85  
E-mail: elektra@elektra.com.tr

 **Ukraine**  
OOO «Intermashtreiding»  
Kostomarowskaja Str. 4  
61002, Kharkow  
Tel./Fax: +380 57 731 96 66  
E-mail: office@imt.in.ua

 **United Kingdom**  
MBS Sulzbach Messwandler Ltd  
Hans Gerlach  
P.O.B. 31635, London W11 3WF  
Tel.: +44 20 77273254  
Fax: +44 20 72219445  
E-mail: Mbshans@aol.com

Nortonics Foxtam Limited  
Bridge Road, Camberley  
Surrey, GU15 2QR  
Tel.: +44 1276 25858  
Fax: +44 1276 25885  
E-mail:  
sales@nortonicsfoxtam.co.uk

## Outside Europe

 **Bahrain**  
TERRAMAR GmbH  
Dorotheenstr. 82  
22301 Hamburg  
Tel: +49 40 27073-0  
Fax: +49 40 27073-350  
E-mail: cfn@terramar.de

 **Costa Rica**  
Wolfgang Rodemann  
11 calle 19-64 Zona15 V.H.3  
Guatemala-Ciudad  
Guatemala C.A.  
Tel.: +502 5693 3987  
Fax: +502 2364 0940  
E-mail: wolfgangrodemann@yahoo.de

 **Egypt**  
Pyram Engineering & Trading S.A.E.  
27, Aloba St., Haram  
7, Juli 26 St.,  
Cairo  
Tel/Fax: +202 5828541  
+202 5828543  
E-mail: pyram@link.net

 **El Salvador**  
Wolfgang Rodemann  
11 calle 19-64 Zona15 V.H.3  
Guatemala-Ciudad  
Guatemala C.A.  
Tel.: +502 5693 3987  
Fax: +502 2364 0940  
E-mail: wolfgangrodemann@yahoo.de

 **Guatemala**  
Wolfgang Rodemann  
11 calle 19-64 Zona15 V.H.3  
Guatemala-Ciudad  
Guatemala C.A.  
Tel.: +502 5693 3987  
Fax: +502 2364 0940  
E-mail: wolfgangrodemann@yahoo.de

 **Honduras**  
Wolfgang Rodemann  
11 calle 19-64 Zona15 V.H.3  
Guatemala-Ciudad  
Guatemala C.A.  
Tel.: +502 5693 3987  
Fax: +502 2364 0940  
E-mail: wolfgangrodemann@yahoo.de

 **Kuwait**  
TERRAMAR GmbH  
Dorotheenstr. 82  
22301 Hamburg  
Tel: +49 40 27073-0  
Fax: +49 40 27073-350  
E-mail: cfn@terramar.de

 **Mexico**  
Wolfgang Rodemann  
11 calle 19-64 Zona15 V.H.3  
Guatemala-Ciudad  
Guatemala C.A.  
Tel.: +502 5693 3987  
Fax: +502 2364 0940  
E-mail: wolfgangrodemann@yahoo.de

 **New Zealand**  
Electrade New Zealand Ltd  
196 Marua Road  
PO Box 11-078  
Ellerslie  
Auckland  
Tel.: +64 9 525 1753  
Fax: +64 9 525 1756  
E-mail: sales@electrade.co.nz

 **Oman**  
TERRAMAR GmbH  
Dorotheenstr. 82  
22301 Hamburg  
Tel: +49 40 27073-0  
Fax: +49 40 27073-350  
E-mail: cfn@terramar.de

 **Peru**  
CEYESA  
Ingenieria Eléctrica S.A.  
Pque. Internacional de la Industria  
y Comercio  
Av. Enrique Meiggs no. 255-257  
Callao  
Tel.: +51 1451 7936 / 452-4565  
Fax: +51 1451 7272 / 451-0617  
E-mail:  
ceyasacomercial@rednextel.com.pe

 **Qatar**  
TERRAMAR GmbH  
Dorotheenstr. 82  
22301 Hamburg  
Tel: +49 40 27073-0  
Fax: +49 40 27073-350  
E-mail: cfn@terramar.de

 **Saudi Arabia**  
Specialize Symbol  
P.O. Box 515  
Riyadh 11421  
Tel.: +966 1 476 5311  
Fax: +966 1 479 3019  
E-mail:  
specializesymbol.ksa@hotmail.com

 **South Africa**  
Fleck Technologies (PTY) LTD  
7 Van der Sterr Road  
Rhodesfield extension 1, Kempton Park  
1620 Johannesburg, Gauteng Province  
Tel.: +27 11 3946308  
Fax: +27 11 3946308  
E-mail: mike.pirie@telkomsa.net

 **Sudan**  
El Watania for Engineering &  
Trading  
3-Ashraf El-Khalq Str., Lebnan  
Sq-El Mohandssen  
Giza, Egypt  
Tel.: +20 233025648  
Fax: +20 233038613  
E-mail: watnia161@hotmail.com

 **United Arab Emirates**  
GDS Gulf Dynamic  
Switchgear Co.Ltd.  
P.O.Box 6155  
Sharjah  
Tel: +971 6533 8568  
Fax: +971 6533 6383  
E-mail: info@gulfdynamic.com

Gama Electro-Mechanics Devices  
Trdg. Co. (LLC)  
P.O. Box 22185  
Sharjah  
Tel: +971 6533 5453  
Fax: +971 6533 8182  
E-mail: info@gama.ae

 **Yemen**  
Al Khaled For General Commercial  
Agencies  
P.O. Box 11153  
Sanaa  
Tel.: +967 1 513532  
Fax: +967 1 500791  
E-mail: aktc1@yahoo.com  
E-mail: dabwan101@yahoo.com.au

# MBS product groups summarized

## Low voltage current transformers for industrial applications

Class 1, 0.5, 0.2s



ASR	Tube current transformers, primary round conductor
ASG	Tube current transformers, hardened
	Tube current transformers for panel boards
ASK	Plug-in current transformers
WSK	Wound current transformers
KBU	Split core current transformers
KSU / SUSK	Summation current transformers
NH	Current transformers for fuse rails
SASR	Protection tube current transformers, primary round conductor
SASK	Protection plug-in current transformers
ASRD 14 / ASRD 210.3	Three-phase current transformer sets
ASKD / WSKD	Three-phase current transformer sets with or without base plate and neutral conductor

## Low voltage current transformers for tariff applications, calibrated or suitable for calibration

Class 0.5, 0.5s, 0.2, 0.2s



EASR	Tube current transformers, primary round conductor
EASK	Plug-in current transformers
EWSK	Wound current transformers
ESUSK	Summation current transformers
EASK(D)	Three-phase current transformer sets
EASKD / EWSKD	Three-phase current transformer sets with or without base plate and neutral conductor

## Accessories for low voltage current transformers

- Snap-on mountings
- Copper tubes
- Mounting angles, mounting kits, secondary caps
- Locking pistons
- Sealed shutters
- Copper bus bars

## Bus bar isolators / Bus bar supports



DB/P	Spacing isolators
CO/P	
CS/P	
CT/P	
CPE	
PI/P	Passing isolators
PSB	Vertical bus bar supports
GB	Mounting material, threaded bolts
SK	Hexagon spacers in brass
	Bus bar supports
	Bus bar support L- and Z-profile

### Additional products

- Shunts
- Amperemeter change-over switch
- Voltmeter change-over switch
- NEOZED-fuse base
- Contact tongue

### Voltage transformers up to 1 kV



MBEV / MBER / MBE	1-pole isolating voltage transformers
MBZV / MBZR / MBZ	2-pole isolating voltage transformers

### Measuring transducers



SWMU	Measuring transducers for AC current with integrated current transformer <ul style="list-style-type: none"> <li>■ with auxiliary voltage supply, 230 V AC</li> <li>■ with auxiliary voltage supply, 24 V DC</li> <li>■ without auxiliary voltage supply</li> </ul>
NMC	Measuring transducers for AC current, for direct notching onto MBS current transformers <ul style="list-style-type: none"> <li>■ with auxiliary voltage supply, 230 V AC, 110 V AC</li> <li>■ with auxiliary voltage supply, 24 V DC</li> <li>■ without auxiliary voltage supply</li> <li>■ measuring range 5 A or 1 A</li> </ul>
NMC-AD	Mounting adaptor for any type of current transformers
NMC-KSx	Short circuit adaptor
FASK	Current transformers with separable, flexible measuring system
EMBSIN	Measuring transducers for electrical variables <ul style="list-style-type: none"> <li>■ AC current with/without auxiliary voltage supply</li> <li>■ AC current with wide range auxiliary voltage supply, effective current value (RMS)</li> <li>■ AC voltage with/without auxiliary voltage supply</li> <li>■ AC voltage with wide range auxiliary voltage supply, effective current value (RMS)</li> <li>■ Frequency with auxiliary voltage supply</li> <li>■ Frequency difference with auxiliary voltage supply</li> <li>■ Phase angle with auxiliary voltage supply</li> <li>■ Phase angle difference with auxiliary voltage supply</li> <li>■ Power factor with auxiliary voltage supply</li> <li>■ Active power with auxiliary voltage supply</li> <li>■ Reactive power with auxiliary voltage supply</li> <li>■ Programmable measuring transducers for AC current with auxiliary voltage supply</li> <li>■ Programmable universal measuring transducers with up to 3 analogue outputs, with auxiliary voltage supply</li> </ul>

### Electronic energy meters for industrial applications



- 1-phase energy meters, direct reading
- 3-phase energy meters, direct reading
- 3-phase energy meters for current transformers
- 3-phase energy meters for current transformers, front mounted 96 x 96 mm
- Electro-mechanical energy meters

### Energy meters for tariff application (suitable for calibration)

- 1-phase energy meters, direct reading
- 3-phase energy meters, direct reading
- 3-phase energy meters for current transformers
- Electro-mechanical energy meters

## Type annotation of MBS current transformers

Our production exclusively comprises low voltage current transformers of the 0.5 series with a max. operating voltage up to 0.72 kV, acc. to DIN VDE 0414, part 1, DIN 42600 and DIN EN 60044/1, edition 12/2003 as well as the regulation VBG 4. For the DIN specification, the most recent information is at all times applicable.

### Our delivery programm comprises:

#### Low voltage current transformers for industrial applications

<b>ASR</b>	<b>Tube current transformers</b> for primary nominal currents from 30 A up to 600 A, secondary nominal currents 5 A or 1 A, optional secondary change-over function, classes 0.5 and 1, optional with copper tube or snap-on mounting
<b>ASG</b>	<b>Tube current transformers</b> for primary nominal currents from 50 A up to 300 A, secondary nominal currents 5 A or 1 A, class 1, with fixed secondary conductors, 2.5 mm <sup>2</sup> connections for nominal wire cross section, measuring system resin hardened  <b>Tube current transformers for panel boards</b> for 50 A up to 1250 A with 1...3 measuring systems integrated in one housing
<b>ASK</b>	<b>Plug-in current transformers</b> for primary nominal currents from 30 A up to 7500 A, secondary nominal currents 5 A or 1 A, optional for dual or triple secondary change-over function, classes 0.2, 0.5 and 1, without primary conductor, but with foot angle, isolator protection cap, and bus bar mounting screws, alternatively with chrome plated. Copper bus bar, conforming to the bus bar window, inclusive of screws DIN 933, complete with nuts, U-discs and springs for the mounting onto bus bars, or similar components
<b>WSK</b>	<b>Wound current transformers</b> for primary nominal currents from 1 A up to 150 A, secondary nominal currents 5 A or 1 A, classes 0.5 and 1, with primary winding and primary connectors instead of a continuous bus bar
<b>KBU</b>	<b>Split core current transformers</b> for primary nominal currents from 100 A up to 5000 A, secondary nominal currents 5 A or 1 A, classes 0.5 and 1, with a separable measuring system for an easy fitment into an already existing installation, without additional mounting requirements. The locking mechanism of the current transformers is to be opened for the installation and is to be closed when the unit is in place, an audible click ensures that the circuit is closed. This unit is ready for operating after the secondary conductors have been connected
<b>KSU / SUSK</b>	<b>Summation current transformers</b> for primary nominal currents from 5 A up to 1 A, secondary nominal currents 5 A or 1 A, classes 0.5 and 1. The numerals following the letter indicate the quantity of how many primary circuits can be connected. Up to 8 connections are possible
<b>NH</b>	<b>Current transformers for fuse rails</b> for primary nominal currents from 100 A up to 600 A, secondary nominal currents 5 A or 1 A, optional secondary change-over switch function, class 3, secondary connections in excess of 4 mm require jacks, for direct mounting onto the contact rail of low voltage-high performance fuses, integrated in the NH fuse set, available in sizes NH 1, NH 2 and NH 3
<b>SASR / SASK</b>	<b>Protection current transformers</b> for primary nominal currents from 50 A up to 2000 A, secondary nominal currents 5 A or 1 A, classes 5P5, 10P5, 5P10, and 10P10. Additional sizes are available upon request.
<b>ASRD / ASK(D) / WSKD / ASKD</b>	<b>Three-phase current transformers</b> for primary nominal currents from 3 x 50 A up to 3 x 750 A, secondary nominal currents 5 A or 1 A, classes 0.5 and 1, optional dual secondary change-over function

Custom-build units correspond in their construction form to the above mentioned technical norms.

**Optimal solution for the application of tube- and plug-in current transformers for low nominal currents**

**Bushing type current transformers**

With low measuring currents up to approximately 50 A it is possible to use a single-phase plug-in current transformer instead of the normally used wound current transformer. The prerequisite of course is, that the primary nominal current of the current transformer corresponds to an integral multiple of the measuring currents. The primary winding will in this case be threaded once or repeatedly through the primary conductor opening.

Primary ct nominal current A	Number of threads	Primary nominal current to be measured A
50	1	50
	2	25
	5	10
	10	5
100	1	100
	2	50
	4	25
	5	20
	10	10
	20	5
150	1	150
	2	75
	3	50
	5	30
	6	25
	10	15
	15	10

**Low voltage current transformers for tariff applications**

**EASR**

**Tube current transformers** for primary nominal currents from 75 A up to 600 A, secondary nominal current 5 A or 1 A, classes 0.2, 0.5s and 0.5 with type approval by PTB Braunschweig for application for tariff purposes.

**EASK**

**Plug-in current transformers** for primary nominal currents from 50 A up to 3200 A, secondary nominal current 5 A or 1 A, classes 0.2, 0.5s, and 0.5 with type approval for the application for tariff purposes.

**EWSK**

**Wound current transformers** for the primary nominal current from 25 A up to 150 A, secondary nominal currents 5 A or 1 A, classes 0.2, 0.5s and 0.5 with type approval for the application for tariff purposes, with primary winding and primary connection terminals instead of a primary conductor opening.

**ESUSK**

**Summation current transformers** for primary nominal currents 5 A, secondary nominal currents 5 A, class 0.2, with type approval for the application for tariff purposes. The numerals following the letter indicate the number of how many primary circuits can be connected, up to 8 connections are possible.

**EASK(D) / EWSKD / EASKD**

**Three-phase current transformers** for primary nominal currents from 3 x 50 A up to 3 x 750 A, secondary nominal currents 5 A or 1 A, classes 0.2, 0.5s and 0.5, optional for dual secondary change-over function with type approval for the application for tariff purposes, for space-saving installation in energy distribution, current transformer set, mounted with primary connecting bus bars and integrated protection cover.

**Note:**

All current transformers for tariff application have been tested at the **Physikalisch Technische Bundesanstalt Braunschweig (PTB) (National Institute of Natural and Engineering Sciences)**. This classification is visual on our name plate.

To differentiate between our current transformers we have arranged for the letter "E" to be set in front of all other references.

**MBS Current Transformers Summarized**

Accuracy classes for sec. 5 A and sec. 1 A with information of max. burden in VA

**Tube Current Transformers**

**Plug-in Current Transformers**

Page	30	31	32	33	34	35	36	38	39	42	43	44	45	46	47	48	49	51	53	55	Page	
	<b>ASR</b> <b>14.3</b> (*)	ASR 20.3 (*)	ASR 201.3 (*)	ASR 21.3 (*)	ASR 21.5	ASR 22.3 (*)	ASR 42.45	ASG 210.3	<b>ASG</b> <b>106</b>	AS 176.3	ASK 176.3	ASK 205.3 (*)	ASK 21.3 (*)	ASK 231.5	ASK 31.3 (*)	ASK 318.3 (*)	ASK 31.4 (*)	ASK 31.5 (*)	ASK 31.6	ASK 41.3 (*)		
Primary nominal current	<b>NEW</b>								<b>NEW</b>												Primary nominal current	
A	1	0.5	1	3	0.5	1	3	1	0.5	1	3	0.5	1	3	0.5	1	3	0.5	1	3	A	
1																						1
2.5																						2.5
5																						5
10																						10
15																						15
20																						20
25																						25
30	1																				1.5	30
40	1						1													1	2.5	40
50	1.5		1		1									1.5	1.25		1		1.5	2.5	2.5	50
60	1.5		1	1.25		1	1.25						1	1.5	1	1.25	1		2.5	2.5	2.5	60
75	1.5		1.5		1.5						1.5		1.5	1	2.5	1.25	2.5	1.5	2.5	2.5	5	75
80			1.5		1.5								1.25	2.5	2.5	5	2.5	2.5	2.5	5	10	80
100		2.5	2.5		2.5	2.5		1	2.5	5	2.5	5		2.5	5	2.5	2.5	2.5	5	5	5	100
125		2.5	3.75		2.5	3.75			2.5	5				2.5	5							125
150		2.5	3.75		2.5	3.75		1.5	5	10	5	5		2.5	5	5	5	2.5	2.5	2.5	7.5	150
200		5	5		5	5		2.5	10	15	5	10		5	5	5	5	5	10	10	15	200
250		5	7.5		5	7.5		5	10	15	10	15		5	10	15	5	10	15	15	15	250
300		5	7.5		5	7.5		5	15	15	10	15		5	10	15	5	10	15	15	15	300
400					10	15	15	10	15	10	15	10		10	10	15	10	10	10	15	30	400
500					10	15	15	10	15	15	10	15		10	15	10	15	10	10	15	30	500
600					10	15	15	10	15	15	10	15		10	15	10	15	15	15	15	30	600
750									15						10	10	15	15	15	15	30	750
800									30													800
1000									30													1000
1200																						1200
1250																						1250
1500																						1500
1600																						1600
1800																						1800
2000																						2000
2500																						2500
3000																						3000
3200																						3200
4000																						4000
5000																						5000
6000																						6000
7500																						7500
primary conductor in mm												20 x 5	20 x 10	30 x 10	30 x 10	31 x 18	30 x 10	30 x 10	30 x 10	30 x 10	40 x 12	primary conductor in mm
round conductor in mm	14	21	21	22.5	21	22.5	42	106				17.5	19.2	28	26	26	28	28	23	26	round conductor in mm	
transform. width in mm	45	45	44	49.5	50	61	71	190				49.5	61	50	61	61	61	61	95	61	transform. width in mm	

CTs with 1 up to 3 different measuring systems upon request; for detailed information see page 39

see also page 20

(\*) For the above mentioned summarized current transformers, snap-on mountings are available for fitment onto 35 mm DIN-rails (DIN 50022).

**Accessories**

Foot- and bus bar mounting screws complete with isolating caps (shock-proof) are included in the supplies. Sealed shutters, copper tubes, snap-on mountings and copper bus bars are available upon request. The transformers are being supplied with integrated secondary locking caps, (exceptions: ASK 31.6, ASK 41.6, ASK 51.6, ASK 61.6, WSK 31.5, WSK 70.6, ASR 201.3).

Plug-in current transformers class 0.2s which can be supplied upon request: ASR 22.3, ASK 21.3, ASK 31.3, ASK 31.4, ASK 31.5, ASK 41.4, ASK 541.4, ASK 51.4, ASK 61.4, ASK 81.4, ASK 105.6, ASK 123.3, ASK 130.3, ASK 130.5

MBS Current Transformers Summarized

Plug-in Current Transformers

Page	57	58	60	61	63	66	67	69	70	72	74	75	76	77	80	84	86	87	88	89	Page				
	ASK 421.4	ASK 41.4 (*)	ASK 41.5 (*)	ASK 412.4	ASK 41.6	ASK 541.4	ASK 51.4	ASK 51.6	ASK 561.4	ASK 61.4	ASK 61.6	ASK 63.4	ASK 63.6	ASK 81.4	ASK 83.4	ASK 101.4	ASK 103.3	ASK 103.41	ASK 105.6	ASK 105.6 N					
Primary nominal current	Accuracy classes for sec. 5 A and sec. 1 A with information of max. burden in VA																				Primary nominal current				
	NEW		NEW		NEW		NEW		NEW		NEW		NEW		NEW		NEW		NEW						
A	0.5	1	3	0.5	1	0.5	1	0.5	1	0.5	1	0.5	1	0.5	1	0.5	1	0.5	1	0.5	1	A			
1																						1			
2.5																						2.5			
5																						5			
10																						10			
15																						15			
20																						20			
25																						25			
30		1							1.5													30			
40	1.5								2.5													40			
50	1.5	2.5		1.5	1.5	1.5	1.5	2.5	2.5													50			
60	1.5	3.75		1.5	2.5	1.5	1.5	2.5	1.5	2.5												60			
75	2.5	5		2.5	2.5	2.5	5	5	2.5	2.5												75			
80	2.5	5		2.5	2.5	2.5	5	5	2.5	5												80			
100	5	10		2.5	3.75	2.5	3.75	1.5	3.75	10	10	5	10	2.5	2.5	5	5					100			
125	5	10		5	5				5	10												125			
150	5	10		5	5	7.5	7.5	2.5	5	15	15	5	10	2.5	2.5	10	10					150			
200	5	15		5	10	7.5	10	2.5	10	15	15	15	15	5	5	10	10					200			
250	10	15		5	10	10	15	5	10	15	15	15	15	5	5	10	15					250			
300	10	15		10	15	15	15	5	15	15	15	15	15	5	5	10	15					300			
400	15	30		10	15	15	15	10	15	15	15	10	15	10	15	15	30	5	10	10	10	15	30	400	
500	15	30		15	15	15	15	10	15	15	15	15	30	5	15	15	15	15	30	5	10	5	10	500	
600				15	15	15	15	10	15	30	30	30	30	15	15	15	30	10	15	15	30	10	15	600	
750				15	15	15	15	15	30	30	30	30	30	10	15	15	30	10	15	15	30	10	15	750	
800				10	30	15	15	15	30	30	30	30	30	15	30	15	45	15	30	15	30	15	30	800	
1000				15	30	15	15		30	45	15	30	15	30	15	30	30	45	15	30	15	30	15	30	1000
1200														15	30	30	45	15	30	30	30	30	45	1200	
1250														15	30	30	45	15	30	30	30	30	45	1250	
1500														30	30	30	45	15	15	15	30	15	45	1500	
1600														30	30	30	45	15	15	15	30	15	45	1600	
1800														15	15			15	30	15	45			1800	
2000														15	15	30	30	15	45	15	30	30	45	2000	
2500														15	30	30	45	30	45			30	45	2500	
3000																		30	45			30	45	3000	
3200																								3200	
4000																						30	45	4000	
5000																						30	45	5000	
6000																								6000	
7500																								7500	
primary conductor	20x10	40x10	40x10 or 2x30x5	40x12	40x12	40x10	50x12	50x12	60x10	63x10	60x10	60x30	60x30	80x10	84x34	100x10	2x100x10	103x41	100x55	100x55	primary conductor				
in mm		2x30x5	2x30x5	30x15	30x15	2x30x5	2x40x10	40x30	2x50x10	2x50x10	50x30	50x40		2x60x10		2x80x10	3x80x10				in mm				
round conductor in mm	20	32	32	30.5	32	32	44	40	44	44	40	44	30	55	34	70	85	40	55	55	round conductor in mm				
transform. width in mm	71	71	71	71	95	86	86	95	86	96	95	96	88	120	96	130	172	99	129	129	transform. width in mm				

see also page 20

(\*) For the above mentioned summarized current transformers, snap-on mountings are available for fitment onto 35 mm DIN-rails (DIN 50022).

**Accessories**

Foot- and bus bar mounting screws complete with isolating caps (shock-proof) are included in the supplies. Sealed shutters, copper tubes, snap-on mountings and copper bus bars are available upon request. The transformers are being supplied with integrated secondary locking caps, (exceptions: ASK 31.6, ASK 41.6, ASK 51.6, ASK 61.6, WSK 31.5, WSK 70.6, ASR 201.3).

Plug-in current transformers class 0.2s which can be supplied upon request: ASR 22.3, ASK 21.3, ASK 31.3, ASK 31.4, ASK 31.5, ASK 41.4, ASK 541.4, ASK 51.4, ASK 61.4, ASK 81.4, ASK 105.6, ASK 123.3, ASK 130.3, ASK 130.5

MBS Current Transformers Summarized

Plug-in Current Transformers								Wound Current Transformers							Split Core Current Transformers				Summation Current Transformers				Page	
Page	90	91	92	94	95	96	97	101	102	103	104	105	106	107	110	110	111	111	116	117	120	Page		
	ASK 123.3	ASK 127.4	ASK 127.6	ASK 128.4	ASK 129.10	ASK 130.3	ASK 130.5 (*)	WSK 30 (*)	WSK 40	WSK 40 N	WSK 60	WSK 70.6	WSK 70.6 N	WSK 31.5	KBU 23	KBU 58	KBU 812	KBU 816	KSU 2...3	SUSK 3...8	NH			
Primary nominal current	Accuracy classes for sec. 5 A and sec. 1 A with information of max. burden in VA																							
	A	0.5	1	0.5	1	0.5	1	0.5	1	0.5	1	0.5	1	0.5	1	0.5	1	0.5	1	0.5	1	current		
1								2.5	5	15	15									15	30	15	30	
2.5								2.5	5	15	15												2.5	
5								2.5	5	15	15		10	15						15	30	15	30	
10								2.5	5	15	15		10	15									10	
15								2.5	5	15	15		10	15									15	
20								2.5	5	15	15		10	15									20	
25									15	15		10	15	10	15	15	15						25	
30									10	10	10	10	15	10	15	10	15	15	15				30	
40									10	10				10	15	10	15	15	15				40	
50									10	10				10	15	10	15	15	15		current circuits	current circuits	50	
60														10	15	10	15	15	15				60	
75														10	15	10	15	15	15				75	
80														10	15	10	15	15	15				80	
100														10	15	10	15	15	15	1.25			100	
125														15	15								125	
150														15	15					1.5			150	
200																			1.5				200	
250																			1.5	1	1.5	1	1.5	
300						5	5	10	10										1.5	3.75	1.5	2.5	1.5	2.5
400				2.5	5	10	10	10	10										2.5	5	1.5	2.5	1.5	2.5
500				2.5	5	10	10	15	15											2.5	5	2.5	5	
600				2.5	5	10	15	15	15											2.5	5	2.5	5	
750				2.5	5	15	15	15	15											2.5	5	2.5	7.5	
800				5	10															2.5	5	2.5	7.5	
1000	10	10	10	10	5	10	10	15	5	15	15	30	30	30					5	10	5	10	10	15
1200	15	15	15	15	10	15	10	15	10	15	15	30	30	30										1200
1250	15	15	30	30	30	30	10	15	10	15	15	30	30	30										1250
1500	15	30	30	30	30	30	15	30	30	30	30	30	30	30										1500
1600		30	30	30			30	30	30	30	30	30	30	30										1600
1800	15	30	30	30	30	30																		1800
2000	30	45	30	45	30	45	15	30	30	30														2000
2500	30	45	45	45	30	45	15	30	45	45														2500
3000	30	45			30	45			30	30														3000
3200									30	45														3200
4000	30	45			30	45			45	45														4000
5000					30	45			30															5000
6000					30	45			45	45														6000
7500					45	45																		7500
primary conductor in mm	123x30 3x100x10	120x70	120x72	128x38	120x90	130x25	130x30								20x30	50x80	80x120	80x160					primary conductor in mm	
round conductor in mm	100	70	72	38	90	25	30								20	50	80	80					round conductor in mm	
transform. width in mm	172	159	205	100	250	180	180	61	71	71	71	60	60	70	93	125	155	195	57	65			transform. width in mm	

see also page 21

(\*) For the above mentioned summarized current transformers, snap-on mountings are available for fitment onto 35 mm DIN-rails (DIN 50022).

Accessories

Foot- and bus bar mounting screws complete with isolating caps (shock-proof) are included in the supplies. Sealed shutters, copper tubes, snap-on mountings and copper bus bars are available upon request. The transformers are being supplied with integrated secondary locking caps, (exceptions: ASK 31.6, ASK 41.6, ASK 51.6, ASK 61.6, WSK 31.5, WSK 70.6, ASR 201.3).

Plug-in current transformers class 0.2s which can be supplied upon request: ASR 22.3, ASK 21.3, ASK 31.3, ASK 31.4, ASK 31.5, ASK 41.4, ASK 541.4, ASK 51.4, ASK 61.4, ASK 81.4, ASK 105.6, ASK 123.3, ASK 130.3, ASK 130.5

MBS Current Transformers Summarized

Protection Current Transformers

Page	127	128	129	130	134	135	136	138	142	144	146	150	152	154	155	Page																																						
	SASR 22.3 (*)	SASK 21.3 (*)	SASK 31.5 (*)	SASK 31.6	SASK 421.4	SASK 41.4	SASK 41.6	SASK 41.10	SASK 541.4	SASK 51.4	SASK 51.6	SASK 61.4	SASK 61.10	SASK 63.6	SASK 105.6																																							
Primary nominal current	Accuracy classes for sec. 5 A and sec. 1 A with information of max. burden in VA															Primary nominal current																																						
A	SP5	10P5	SP5	10P5	SP5	10P5	SP10	10P10	SP4	SP5	10P5	SP5	10P5	SP5	10P5	SP10	10P10	SP5	10P5	SP10	10P10	SP5	10P5	SP10	10P10	SP5	10P5	SP5	10P5	A																								
50						2.5	2.5																								50																							
60						2.5	2.5	1.5	1.5																						60																							
75								1																							75																							
80						1	2.5	2.5		1.5																					80																							
100		1			1.5	1.5	5	5	1.5	2.5									2.5	2.5	1.5	1.5	10	15				5	1.5	1.5	100																							
120																				1	1										120																							
125	1.5	1.5	1	1.5	1.5	1.5														1	1										125																							
150	1.5	1.5	1.5	1.5	1.5	1.5	7.5	7.5	2.5	2.5										1	1.5	5	5	2.5	2.5	15	15			2.5	2.5	150																						
200	1.5	1.5	1.5	1.5	1.5	2.5	10	10	2.5	5	2.5	2.5	2.5	1.5	1.5	7.5	7.5	2.5	2.5	15	15	7.5	10	2.5	2.5			1	1.5	5	5	1.5	1.5	1.5	1.5	200																		
250	1.5	1.5			2.5	2.5	10	10	5	5	2.5	2.5	2.5	2.5	1.5	10	10	2.5	5	15	15	10	15	2.5	2.5			1.5	1.5	2.5	5	7.5	2.5	2.5	1.5	1.5	10	10	5	7.5	2.5	2.5	250											
300	1.5	1.5			2.5	2.5	10	10	5	5	2.5	2.5	2.5	2.5	2.5	10	10	5	5	15	15	10	15	2.5	5	1.5	1.5	1.5	2.5	7.5	7.5	2.5	2.5	2.5	2.5	2.5	15	15	7.5	10	2.5	2.5	300											
400					2.5	2.5	15	15	5	5	2.5	2.5	2.5	2.5	2.5	10	10	7.5	7.5	15	15	15	15	15	5	5	1.5	1.5	1.5	2.5	7.5	7.5	2.5	2.5	2.5	2.5	15	15	15	15	5	5	400											
500					2.5	2.5	15	15	7.5	7.5									2.5	2.5	10	10	10	10	15	15	15	15	5	7.5	2.5	2.5	1.5	2.5	10	10	2.5	2.5	15	15	15	15	5	5	500									
600					2.5	2.5	15	15	7.5	10									2.5	2.5	10	10	7.5	7.5	15	15	15	15	5	7.5	2.5	2.5	1.5	2.5	10	10	2.5	2.5	5	5	15	15	15	15	5	5	5	5	600					
750					1.5	5																																										750						
800																																																	800					
1000																																																	1000					
1200																																																		1200				
1250																																																		1250				
1500																																																			1500			
1600																																																				1600		
1800																																																				1800		
2000																																																				2000		
2500																																																				2500		
3000																																																					3000	
4000																																																					4000	
5000																																																					5000	
6000																																																						6000
7500																																																					7500	
primary conductor		20 x 10	30 x 10		30 x 10		20 x 10	40 x 10	40 x 12		40 x 10	40 x 10	50 x 12	50 x 12	60 x 10	60 x 10	60 x 30	100 x 55																																		primary conductor		
in mm			2x20x10		20x13		2x30x5	30x15				2x30x5	2x40x10	40x30	2x50x10	0x30																																			in mm			
round conductor	22.5	19.2	28		23		20	32	32		32	32	44	40	44	30	30	55																																round conductor				
in mm																																																					in mm	
transform. width	61	61	61		95		71	71		95		150	86	86	95	96	150	88	129																																transform. width			
in mm																																																					in mm	

(\*) For the above mentioned summarized current transformers, snap-on mountings are available for fitment onto 35 mm DIN-rails (DIN 50022).

**Accessories**

Foot- and bus bar mounting screws complete with isolating caps (shock-proof) are included in the supplies. Sealed shutters, copper tubes, snap-on mountings and copper bus bars are available upon request. The transformers are being supplied with integrated secondary locking caps, (exceptions: ASK 31.6, ASK 41.6, ASK 51.6, ASK 61.6, WSK 31.5, WSK 70.6, ASR 201.3).

Plug-in current transformers class 0.2s which can be supplied upon request: ASR 22.3, ASK 21.3, ASK 31.3, ASK 31.4, ASK 31.5, ASK 41.4, ASK 541.4, ASK 51.4, ASK 61.4, ASK 81.4, ASK 105.6, ASK 123.3, ASK 130.3, ASK 130.5

### MBS Current Transformers Summarized

#### Current Transformers for Tariff Application

Page	168	169	170	171	172	173	174	176	177	178	179	180	181	184	Page														
Primary nominal current	<b>EASR</b> <b>14.3</b> (*)	EASR 22.3 (*)	EASK 21.3 (*)	EASK 31.3 (*)	EASK 31.4 (*)	EASK 31.5 (*)	EASK 31.6	EASK 41.4 (*)	<b>EASK</b> <b>41.5</b> (*)	EASK 41.6	EASK 541.4	EASK 51.4	EASK 51.6	EASK 61.4	Primary nominal current														
	Accuracy classes for sec. 5 A and sec. 1 A with information of max. burden in VA																												
	<b>NEW</b>					<b>NEW</b>																							
A	0.2	0.5(s)	0.2	0.5(s)	0.2	0.5(s)	0.2	0.5(s)	0.2(s)	0.5(s)	0.2	0.5(s)	0.2	0.5(s)	0.2	0.5(s)	0.2	0.5(s)	0.2	0.5(s)	0.2	0.5(s)	0.2	0.5(s)	0.2	0.5(s)	A		
1																											1		
2.5																											2.5		
5																											5		
10																											10		
15																											15		
20																											20		
25																											25		
30																											30		
40																											40		
50										2.5																	50		
60																											60		
75		1.5								2.5	5				2.5	5	2.5										75		
80		1.5								2.5					2.5												80		
100	1.5	1.5	1.5	2.5	1.5	2.5	1.5	2.5	2.5	2.5	2.5	5	5	10	1.5	2.5	1.5	2.5	2.5	10	2.5	5		2.5	2.5	5	100		
120	1.5	2.5																										120	
125	2.5	2.5															2.5	2.5									125		
150	2.5	2.5	2.5	5	2.5	5	1.5	2.5	2.5	5	5	5	5	15	2.5	5	2.5	5	5	15	5	10	1.5	2.5	5	10	150		
200		5	5	5	5	5	5	5	5	10	10	15	5	5	5	5	5	5	15	10	15	5	5	5	10	2.5	2.5	200	
250		5	5	5	5	5	5	5	5	10	15	10	15	5	5	10	10	10	15	10	15	5	5	10	15	5	5	250	
300		5	10	5	10	5	5	10	10	10	15	10	30	5	10	10	15	15	15	15	15	5	5	10	15	5	10	300	
400		10	10	10	10	5	5	10	10	10	15	15	30	10	10	10	15	15	15	15	15	30	10	10	10	15	10	400	
500		10	10	10	10	5	5	10	10	10	15	15	30	15	15	10	15	15	15	15	15	30	10	10	10	15	10	500	
600		10	10			5	5	10	15	10	15	15	30	15	15	15	15	15	15	15	15	30	15	15	15	15	15	600	
750					5	5	10	15	10	15	15	30	10	15	15	15	15	15	15	30	15	30	15	15	15	15	15	750	
800																	15	15										800	
1000																	15	15	15	30	15	30	15	15	15	30	10	30	1000
1200																											15	30	1200
1250																										15	30	1250	
1500																										15	30	1500	
1600																												1600	
1800																												1800	
2000																												2000	
2400																												2400	
2500																												2500	
3000																												3000	
3200																												3200	
4000																												4000	
5000																												5000	
6000																												6000	
7500																												7500	
primary conductor in mm				20 x 10	30 x 10	30 x 10	30 x 10	30 x 10	40 x 10	40 x 10	40 x 12	40 x 10	50 x 12	50 x 12	60 x 10													primary conductor in mm	
round conductor in mm	14	22.5	19.2	26	28	28	23	32	32	32	32	44	40	44														round conductor in mm	
transformer width in mm	44	61	61	61	61	61	95	71	71	95	86	86	95	96														transformer width in mm	

(\*) For the above mentioned summarized current transformers, snap-on mountings are available for fitment onto 35 mm DIN-rails (DIN 50022).

**Accessories**

Foot- and bus bar mounting screws complete with isolating caps (shock-proof) are included in the supplies. Sealed shutters, copper tubes, snap-on mountings and copper bus bars are available upon request. The transformers are being supplied with integrated secondary locking caps, (exceptions: ASK 31.6, ASK 41.6, ASK 51.6, ASK 61.6, WSK 31.5, WSK 70.6, ASR 201.3). Plug-in current transformers class 0.2s which can be supplied upon request: ASR 22.3, ASK 21.3, ASK 31.3, ASK 31.4, ASK 31.5, ASK 41.4, ASK 541.4, ASK 51.4, ASK 61.4, ASK 81.4, ASK 105.6, ASK 123.3, ASK 130.3, ASK 130.5

**MBS Current Transformers Summarized**

Current Transformers for Tariff Application

Page	185	186	187	190	191	192	193	196	197	Page
	EASK 61.6	EASK 63.6	EASK 81.4	EASK 105.6	EASK 123.3	EASK 130.3	EASK 130.5	EWSK 31.5	ESUSK 2...8	
Primary nominal current	Accuracy classes for sec. 5 A and sec. 1 A with information of max. burden in VA								Primary nominal current	
A	0.2 0.5(s)	0.2 0.5(s)	0.2 0.5(s)	0.2 0.5(s)	0.2 0.5(s)	0.2 0.5(s)	0.2 0.5(s)	0.2 0.5(s)	0.2	A
1										1
2.5										2.5
5									10	5
10										10
15										15
20										20
25								10 15		25
30								10 15		30
40								10 15		40
50								10 15		50
60								10 15		60
75								10 15		75
80										80
100								10 15		100
120										120
125										125
150								10 15		150
200	2.5 5									200
250	5 10	2.5 5								250
300	10 15	5 10								300
400	10 15	10 10	5 10			2.5 5	2.5 10			400
500	10 15	10 15	10 10			2.5 5	2.5 10			500
600	10 30	15 15	10 15	5 5		5 5	5 10			600
750	15 15	15 30	10 15	10 10		10 5	10 15			750
800										800
1000	15 30	15 30	10 15	15 15	5 10	5 15	15 30			1000
1200	15 30	15 30	10 15	15 15	10 15	10 15	15 30			1200
1250	15 30	15 30	15 15	15 30	15 15	15 15	15 30			1250
1500	15 30	15 30	15 15	30 30	15 30	15 30	15 30			1500
1600				30 30	15 30	15 30	15 30			1600
1800										1800
2000				30 30	15 30		30 30			2000
2400							30 30			2400
2500				30 30	15 30		30 30			2500
3000				30 30	30 45		30 30			3000
3200										3200
4000										4000
5000										5000
6000										6000
7500										7500
primary conductor	60 x 10	60 x 30	80 x 10	100 x 55	123 x 30	130 x 25	130 x 30			primary conductor
in mm			60 x 30							in mm
round conductor			2x60x10		3x100x10					round conductor
in mm	40	30		55	100	25	30			in mm
transformer width										transformer width
in mm	95	88	120	129	172	180	180	70	65	in mm

(\*) For the above mentioned summarized current transformers, snap-on mountings are available for fitment onto 35 mm DIN-rails (DIN 50022).  
**Accessories**  
 Foot- and bus bar mounting screws complete with isolating caps (shock-proof) are included in the supplies. Sealed shutters, copper tubes, snap-on mountings and copper bus bars are available upon request. The transformers are being supplied with integrated secondary locking caps, (exceptions: ASK 31.6, ASK 41.6, ASK 51.6, ASK 61.6, WSK 31.5, WSK 70.6, ASR 201.3).  
 Plug-in current transformers class 0.2s which can be supplied upon request: ASR 22.3, ASK 21.3, ASK 31.3, ASK 31.4, ASK 31.5, ASK 41.4, ASK 541.4, ASK 51.4, ASK 61.4, ASK 81.4, ASK 105.6, ASK 123.3, ASK 130.3, ASK 130.5

# Current transformers – Technical characteristics

Current transformers are special transformers for the proportional transformation of high currents into directly measurable values. Their construction and physical operating principle enables a galvanic separation of the primary circuit from the measured circuit, thereby providing a protection for sequentially connected instruments in the event of a fault.

<b>Rated limit current</b> [I <sub>PL</sub> ]	value of the lowest primary current where, by the secondary measuring burden, the total deviation of the current transformer for measuring purposes is equal to or greater than 10 %.						
<b>Rated current intensity</b> [I <sub>N</sub> ]	is the noted specified value of the primary and secondary current on the rating plate. Standardized primary nominal currents have the following values: 5 A, 10 A, 15 A, 20 A, 25 A, 30 A, 40 A, 50 A, 60 A, 75 A, 100 A with a decadic multiple of the previously mentioned value to a max. of 7500 A. Standardized secondary nominal currents have the values 5 A and 1 A.						
<b>Rated power</b>	the value of the apparent power (in a VA specified power factor), which the current transformer is intended to supply to the secondary circuit and rated burden at the rated secondary current.						
<b>Earthing of secondary terminals</b>	according to VDE 0141, section 5.3.4., current- and voltage transformers have to be earthed, starting from U <sub>m</sub> = 3.6 kV. With low voltage (up to U <sub>m</sub> – 1.2 kV) no earthing is required, as long as the transformer housings have no visible exposed metal surfaces.						
<b>Phase displacement error</b> [δ]	signifies the phase shift of the primary current and the secondary current. The direction of the indicator is arranged in such a way, that with an optimum produced current transformer the phase displacement error is equal to zero (IEV 321-01-23 modified). The phase displacement error is to be regarded as positive when the indicator of the secondary current is ahead compared to the indicator of the primary current. The phase displacement error is specified in minutes or hundredths of a radiant. Note: Strictly speaking this definition is only valid for sinus type currents.						
<b>Accuracy class</b>	the denotation for a current transformer whose measuring deviation remains below the prescribed operating condition.						
<b>Total measuring deviation (Current error)</b>	is the effective value in stationary position, and the difference between: a) the momentary value of the primary current and b) the momentary value of the measuring transmission of the multiplied actual secondary current, whereby the positive indicators of the primary and secondary current correspond to the accord for the connection denotation. The total deviation F <sub>1</sub> is generally rendered in the percentages of the effective value of the primary current, as per the following mathematical equation.						
$F_1 = \frac{100}{I_p} \sqrt{\frac{1}{T} \int_0^T (K_N i_s - i_p)^2 dt}$							
<table border="0" style="width: 100%;"> <tr> <td style="width: 50%;">F<sub>1</sub> = total measuring deviation in %</td> <td style="width: 50%;">i<sub>p</sub> = momentary value of the primary current</td> </tr> <tr> <td>K<sub>N</sub> = rated measuring transmission</td> <td>i<sub>s</sub> = momentary value of the secondary current</td> </tr> <tr> <td>I<sub>p</sub> = effective value of the primary current</td> <td>T = duration of period</td> </tr> </table>		F <sub>1</sub> = total measuring deviation in %	i <sub>p</sub> = momentary value of the primary current	K <sub>N</sub> = rated measuring transmission	i <sub>s</sub> = momentary value of the secondary current	I <sub>p</sub> = effective value of the primary current	T = duration of period
F <sub>1</sub> = total measuring deviation in %	i <sub>p</sub> = momentary value of the primary current						
K <sub>N</sub> = rated measuring transmission	i <sub>s</sub> = momentary value of the secondary current						
I <sub>p</sub> = effective value of the primary current	T = duration of period						
<b>Max. voltage for electrical equipment U<sub>m</sub></b>	this denotes the highest constant permitted value for phase to phase voltage for which the current transformers isolation is rated.						
<b>Burden</b>	the impedance of the secondary current is declared in ohms and power factor. The burden is usually expressed as the apparent power in voltamperes, absorbed at a specified power-factor and at the rated secondary current.						
<b>Rated burden</b>	the value of the burden upon which the accurate requirements of this specifications are based.						
<b>Rated surge current</b> [I <sub>DYN</sub> ]	peak value of the primary current, whose electro-mechanical impact is resisted by the current transformer with short circuited secondary winding. The value of the nominal search current I <sub>DYN</sub> has to be 2.5 x I <sub>TH</sub> . Only when there is a deviation from this value, the rating plate has to state I <sub>DYN</sub> .						
<b>Actual transformation ration</b>	is the ratio of the primary nominal current to the secondary current. It is specified as an unabridged break on the rating plate.						

**Open circuit voltage of current transformers**

current transformers, which are not directly encumbered with a burden, are generally secondarily short circuited. A secondary open current transformer operates like a loaded one with an almost infinitely high burden. The curve shape of the secondary current is extremely deformed and under certain conditions voltage surges occur which can be harmful to human beings. The amount of the induced "loss motion" depends on the core cross-section and the number of secondary turns. For MBS current transformers of lower ratings and with a nominal transmission ratio up to 500/5, the peak value of this voltage is  $\hat{U} \leq 200 \text{ V}$ . For reasons of hazard protection and to prevent magnetization of the iron core, an open secondary circuit is to be avoided.

**Bus bar cross section**

the openings of our individual plug-in transformers for the acceptance of primary bus bars or their cross-sections – even when supplied with copper bus bars – are not decisive for the dimensioning of the bus bar units. The cross section of the bus bar is permitted to be smaller over a short distance in the transformer area, provided the adjacent bus bar cross sections are dimensioned in such a manner that any possible excess heat can easily be absorbed.

**Special configurations**

saturation transformers	upon request
tropicalized versions	upon request
primary nominal currents deviating from the standard series	upon request
secondary change-over units	refer to the relevant types of ct's
deviating frequency (16 2/3 Hz up to 400 Hz)	upon request
resin hardened for extreme mechanical demands (shakeproof)	upon request

**Current error**

is the percentage deviation of the nominal transmission multiplied by the secondary current from that of the primary current. The current error is calculated positively, should the actual value of the secondary current exceed the nominal value.

$$F_I = \frac{I_S K_N - I_P}{I_P} 100 \%$$

$F_I$ = current error in %	$I_S$ = secondary current in A (effective value)
$I_P$ = primary current in A (effective value)	$K_N$ = rated measuring ratio

**Thermal nominal continuous rated current  $[I_b]$**

is the primary current which allows the continuous operation of the current transformer. When using this current value, the temperature of the secondary wiring must not exceed the prescribed values mentioned in the actual technical norms. These values are in direct relation to the isolation material class. Should a thermal rated current be defined which is larger than the primary rated current, the preference values of 120 %, 150 % and 200 % should reflect those of the primary rated current.

**Thermal rated short-time current  $[I_{TH}]$**

this value indicates the effective value of the primary current which the current transformers can withstand with short circuited secondary winding. Other rated measuring values as 1s, e.g. 0.5s, 2s and 3s are acceptable. The thermal short time rated current  $I_{th}$  has to be stated for each current transformer.

**Over-current rated limiting factor (FS)**

is the ratio of the limit rated current to the primary rated current.  
 Note 1: It ought to be noted that the actual over-load rated current is influenced by the burden.  
 Note 2: Should the primary winding of the current transformer be short-circuited, the safety is greatest, when the value of the over-load current limit factor "FS" is small.  
 The excess current limiting factor is indicated on the rating plate of a measuring transformer with a nominal value after the letters "FS".

The specification "FS 5" signifies that the total measurement deviation of the current transformer with 5 times the primary nominal current arising from the magnetic saturation of the iron core amounts at least up to 10 %.


**Important:**

All MBS current transformers are in accordance with DIN EN 60044/1 for a thermal nominal current of  $I_d = 1.0 \times I_N$ .

## MBS current transformer range for tariff applications

In addition to a comprehensive selection of standard current transformers in the accuracy classes 0.5 and 1, MBS AG manufactures an extensive product range of tariff transformers for currents between 25 A and 3200 A in the classes 0.2s, 0.2, 0.5s, and 0.5.

These approved current transformers have the national certificate of Germany and of several European countries.

The current transformers which have been approved by the Physikalisch Technische Bundesanstalt (PTB) Braunschweig (an authorized German testing laboratory) are recognizable by a stylized  plus a construction series number. An "E" is placed before the usual MBS type mark.

The calibration of the transformers is documented by an official lead seal as well as an additional affixed yellow calibration stamp. The fees for the calibration are calculated in accordance with the applicable official regulation.

The calibration of the transformers is performed upon request at the **"Staatlich anerkannte Prüfstelle für Messgeräte für Elektrizität EA90"** State Approved Testing Laboratories for Measuring Appliances for Electricity EA90 as represented by MBS AG.

## Configuration of MBS low voltage current transformers

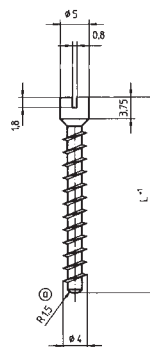
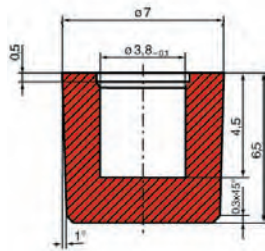
All at MBS AG manufactured low voltage current transformers correspond to DIN VDE 0414/1; DIN 42600; and DIN EN 60044/1 edition 12/2003 as well as regulation VBG 4.

### Characteristics of the current transformers:

- unbreakable plastic housings
- black polycarbonate
- flame resistant
- self-extinguishing
- transformer housings are ultrasonically welded
- nickel-plated secondary terminals with plus-minus nickel-plated screw M 5x10 mm
- integrated secondary locking caps.

**Foot angle and bus bar mounting screws with isolating protection caps** (protection-proof) are supplied free of charge. All transformers are suitable for use on massive primary conductors as well as on flexible isolated copper strips.

Isolating protecting cap



M 1:1



Bus bar mounting screw, screw length (L) 25, 32, 36, 46, 54, 80 mm, torque 0.5 Nm

### General technical specifications:

<b>Nominal frequency</b>	50 Hz (16 <sup>2</sup> /3 Hz up to 400 Hz upon request)
<b>Isolation class</b>	E
<b>Thermal nominal short-time current</b>	$I_{th} = 60 \times I_N$
<b>Maximum operating voltage</b>	$U_m \leq 0.72 \text{ kV}$
<b>Over-current limiting factor</b>	FS 5 or FS 10 correct value see name plate other values upon request
<b>Secondary nominal current</b>	5 A or 1 A
<b>Operating temperature</b>	$-5 \text{ °C} \leq \vartheta \leq +40 \text{ °C}$
<b>Storage temperature</b>	$-25 \text{ °C} \leq \vartheta \leq +70 \text{ °C}$

## Error limit values for measuring transformers for classes 0.2 .... 3 according to DIN IEC 60044/1

Class accuracy	Current error $\pm \partial_F$ by					Phase displacement error $\pm \partial_F$ by				
	1.2 I <sub>N</sub> 1.0 I <sub>N</sub>	0.2 I <sub>N</sub>	0.1 I <sub>N</sub>	0.05 I <sub>N</sub>	0.01 I <sub>N</sub>	1.2 I <sub>N</sub> 1.0 I <sub>N</sub>	0.2 I <sub>N</sub>	0.1 I <sub>N</sub>	0.05 I <sub>N</sub>	0.01 I <sub>N</sub>
	%	%	%	%	%	min	min	min	min	min
0.2	0.2	0.35		0.75		10	15		30	
0.2s	0.2	0.2		0.35	0.75	10	10		15	30
0.5	0.5	0.75		1.5		30	45		90	
0.5s	0.5	0.5		0.75	1.5	30	30		45	90
1	1	1.5		3		60	90		180	
3	3					120.0*				

\* by 0.5 I<sub>N</sub> and thermal nominal continuous current

## Error limit values for current transformers for protection applications

Class accuracy	Current error $\pm F_i$ by				Phase displacement error $\pm F_i$ by			
	1.0 I <sub>N</sub> and thermal nominal continuous current	0.5 I <sub>N</sub>	0.2 I <sub>N</sub>	0.05 I <sub>N</sub>	1.0 I <sub>N</sub> and thermal nominal continuous current	0.5 I <sub>N</sub>	0.2 I <sub>N</sub>	0.05 I <sub>N</sub>
	%	%	%	%				
5 P ...	1		1.5	3	60		90	120
10 P ...	3	3			120	120		

Current error F<sub>g</sub> at nominal error current limit and nominal burden class 5P ... ≤ 5 %  
class 10P ... ≤ 10 %

## Maximum permissible current of copper bus bars Dimensions and current values according to DIN 43671

Bus bar cross section	1 bus bar	2 bus bars	3 bus bars
20 x 10	427 A	825 A	1180 A
30 x 05	379 A	672 A	896 A
30 x 10	573 A	1060 A	1480 A
40 x 05	482 A	836 A	1090 A
40 x 10	715 A	1290 A	1770 A
50 x 10	852 A	1510 A	2040 A
60 x 10	985 A	1720 A	2300 A
80 x 10	1240 A	2110 A	2790 A
100 x 10	1490 A	2480 A	3260 A
bus bar surface		clear	

Above values are valid for continuous current burden at approx. 30 °C ambient temperature.

## Markings of the current transformers connection terminals

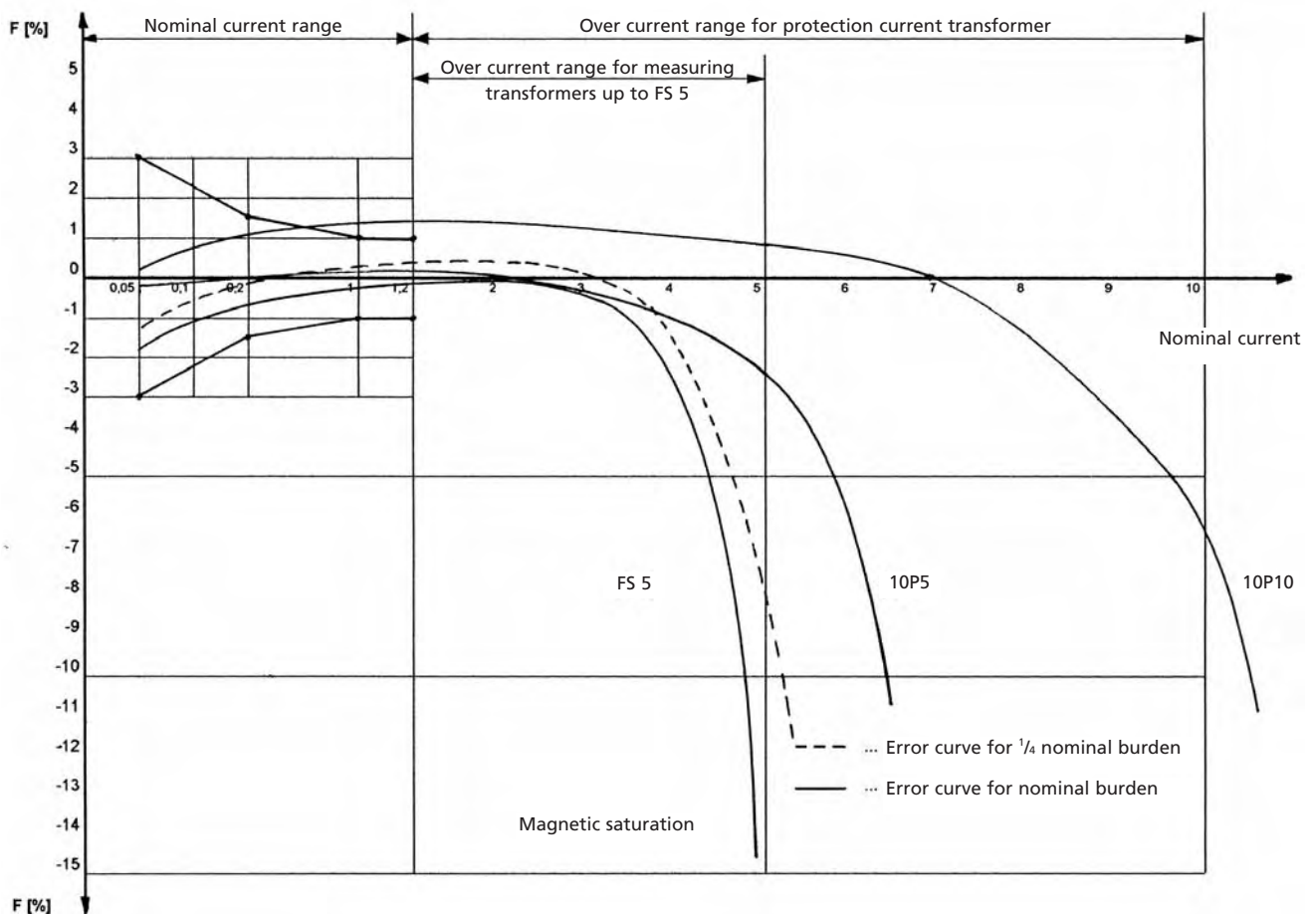
The connections of all primary windings are marked with capital letters "K-P<sub>1</sub>", and "L-P<sub>2</sub>".

The connections of all secondary windings are marked with the corresponding lower case letters "k-s<sub>1</sub>" and "l-s<sub>2</sub>".

By current transformers with a multiple secondary windings the winding end is marked "I", followed by the prefix letter "I<sub>1</sub>", the windings with a decreasing number of windings are sequentially numbered "2", "3" etc.

By current transformers with a multiple of independent primary windings, the terminals of the individual windings are distinguishable from the additional capital letters set before "K" and "L" and the additional capital letters "A", "B", "C" etc.; i.e. "AK" – "AL" for the highest primary circuit, "BK" – "BL" for the second primary circuit etc.; or on each terminal pair the transmission or the ratio transmission of the individual primary windings to each other is to be specified.

## Error curves of low voltage current transformers



## Power requirements of measuring units and relays

Two main requirements are cited by the user for the principle demands of current transformers:

- a high degree of measuring precision in the range of nominal current
- a protection function in the over-load range

In order to fulfill these demands it is necessary for the assumed nominal power of a current transformer to fully achieve the actual power requirements of the prescribed measurements.

In ascertaining the actual power requirements, consideration is to be given to power losses of the appliances to be connected, as well as to the losses of the measuring conductor.

### Power requirements of typical measuring units

Current meter soft ironed up to 100 mm Ø	0.700	–	1.500 VA
Rectifier current meter	0.001	–	0.250 VA
Multi-range current meter	0.005	–	5.000 VA
Current recorder	0.300	–	9.000 VA
Bimetal current meter	2.500	–	3.000 VA
Power meter	0.200	–	5.000 VA
Power recorder	3.000	–	12.000 VA
Power factor meter	2.000	–	6.000 VA
Power factor recorder	9.000	–	16.000 VA
Energy meter (current path)	0.400	–	1.000 VA
Relay			14.000 VA
N-relay			
Over current relay	0.200	–	6.000 VA
Over current time relay	3.000	–	6.000 VA
Direction relay			10.000 VA
Bimetal relay	7.000	–	11.000 VA
Distance relay	1.000	–	30.000 VA
Differential relay	0.200	–	2.000 VA
	1.000	–	15.000 VA
Transformer current trip switch	5.000	–	150.000 VA
Controler	5.000	–	180.000 VA

### Power consumption of copper wires

$$P = \frac{I^2 \times 2l}{q_{cu} \times 56} \text{ [VA]}$$

$I$  = secondary nominal current  
 $l$  = distance in m  
 $q_{cu}$  = wire cross section in mm<sup>2</sup>

Comment: With a joint three phase current return conductor the values of P are halved.

#### Chart for values referring to 5 A

Nominal cross section	1 m	2 m	3 m	4 m	5 m	6 m	7 m	8 m	9 m	10 m
2.5 mm <sup>2</sup>	0.36	0.71	1.07	1.43	1.78	2.14	2.50	2.86	3.21	3.57
4.0 mm <sup>2</sup>	0.22	0.45	0.67	0.89	1.12	1.34	1.56	1.79	2.01	2.24
6.0 mm <sup>2</sup>	0.15	0.30	0.45	0.60	0.74	0.89	1.04	1.19	1.34	1.49
10.0 mm <sup>2</sup>	0.09	0.18	0.27	0.36	0.44	0.54	0.63	0.71	0.80	0.89

#### Chart for values referring to 1 A

Nominal cross section	10 m	20 m	30 m	40 m	50 m	60 m	70 m	80 m	90 m	100 m
1.0 mm <sup>2</sup>	0.36	0.71	1.07	1.43	1.78	2.14	2.50	2.86	3.21	3.57
2.5 mm <sup>2</sup>	0.14	0.29	0.43	0.57	0.72	0.86	1.00	1.14	1.29	1.43
4.0 mm <sup>2</sup>	0.09	0.18	0.27	0.36	0.45	0.54	0.63	0.71	0.80	0.89
6.0 mm <sup>2</sup>	0.06	0.12	0.18	0.24	0.30	0.36	0.42	0.48	0.54	0.60
10.0 mm <sup>2</sup>	0.04	0.07	0.11	0.14	0.18	0.21	0.25	0.29	0.32	0.36

## Tube current transformers, series ASR



[www.mbs-ag.com](http://www.mbs-ag.com)

# Low voltage current transformers for industrial applications

## Tube current transformers

**ASR 14.3**

**NEW**

Round conductor  
Transformer width

Ø 14 mm  
45 mm



**ASR 20.3**

Round conductor  
Transformer width

Ø 21 mm  
45 mm



**ASR 201.3**

without locking cap

Round conductor  
Transformer width

Ø 21 mm  
44 mm



**ASR 21.3**

Round conductor  
Transformer width

Ø 22.5 mm  
49.5 mm



**ASR 21.5**

Round conductor  
Transformer width

Ø 21 mm  
50 mm



**ASR 22.3**

**ASR 22.3 2U**

Round conductor  
Transformer width

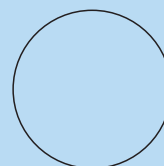
Ø 22.5 mm  
61 mm



**ASR 42.45**

Round conductor  
Transformer width  
Transformer depth

Ø 42 mm  
71 mm  
45 mm

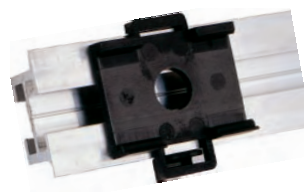
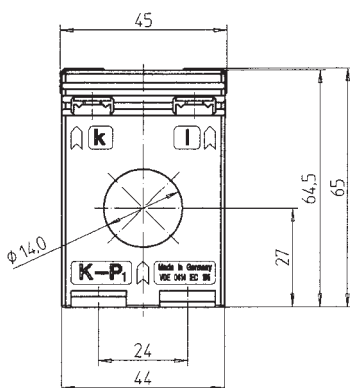
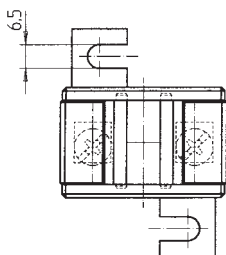
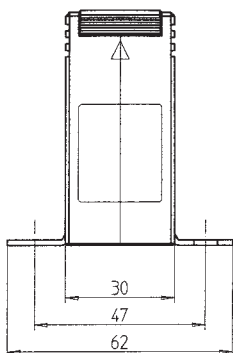


# ASR 14.3

Tube current transformer



Secondary current		5A		1A	
Primary current	Burden	Accuracy class		Accuracy class	
		1	0.5	1	0.5
A	VA	Art.-no.	Art.-no.	Art.-no.	Art.-no.
30	1	26080		26280	
40	1	26081		26281	
50	1.5	26082		26282	
60	1.5	26083		26283	
75	1.5	26084		26284	

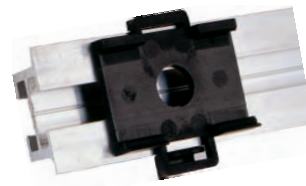
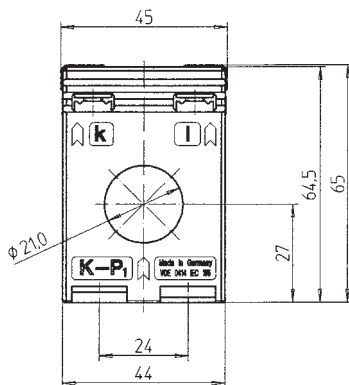
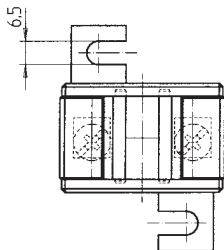
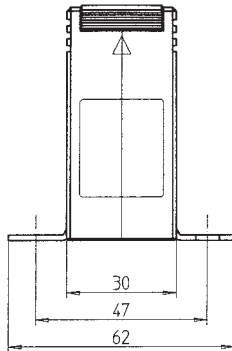


Snap-on mounting

Primary conductor	
Round conductor	Ø 14.0 mm
Transformer width	45 mm
Snap-on mounting	<b>Art.-no. 55013</b> see page 206
Sealed shutter	—
Copper tubes	see page 206
Current transformer for tariff applications	see page 168

# ASR 20.3

## Tube current transformer



Snap-on mounting

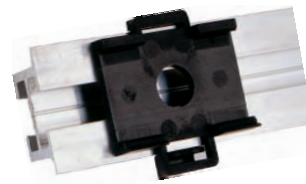
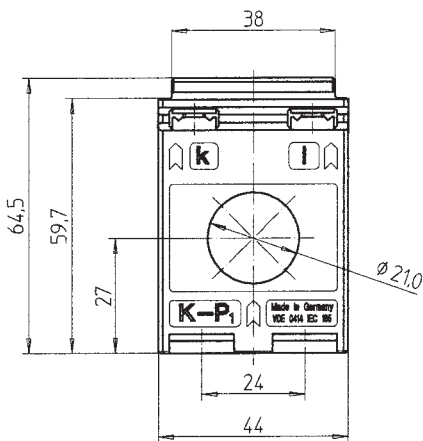
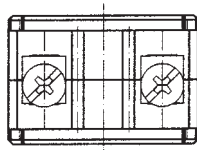
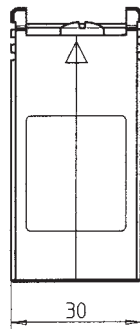
Secondary current		5A			1A		
Primary current A	Burden VA	Accuracy class			Accuracy class		
		3	1	0.5	3	1	0.5
		Art.-no.	Art.-no.	Art.-no.	Art.-no.	Art.-no.	Art.-no.
50	1	26027			26227		
60	1		26028			26228	
	1.25	26029			26229		
75	1.25		26030			26230	
	1.5		26031			26231	
80	1.25		26032			26232	
	1.5		26033			26233	
100	1.5		26034	26011		26234	26211
	2.5		26035			26235	
125	1.5		26036	26013		26236	26213
	2.5		26037			26237	
	3.75		26038		26238		
150	1.5		26039	26015		26239	26215
	2.5		26040	26016		26240	26216
	3.75		26041			26241	
200	1.5		26042	26017		26242	26217
	2.5		26043	26018		26243	26218
	3.75					26244	26219
250	2.5		26045	26020		26245	26220
	5		26046	26021		26246	26221
300	2.5		26048	26022		26248	26222
	5		26049	26023		26249	26223

Primary conductor	
Round conductor	Ø 21.0 mm
Transformer width	45 mm
Snap-on mounting	<b>Art.-no. 55013</b> see page 206
Sealed shutter	—
Copper tubes	see page 206



# ASR 201.3

Tube current transformer



Snap-on mounting

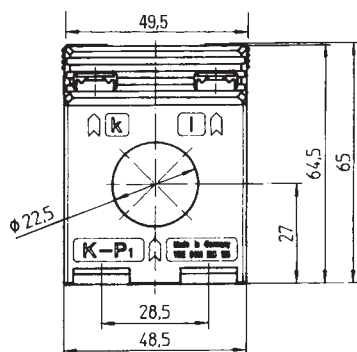
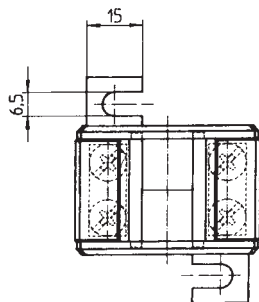
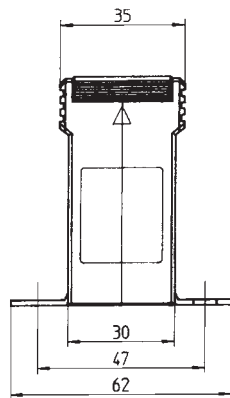
Secondary current		5A			1A		
Primary current A	Burden VA	Accuracy class			Accuracy class		
		3	1	0.5	3	1	0.5
		Art.-no.	Art.-no.	Art.-no.	Art.-no.	Art.-no.	Art.-no.
50	1	27027			27227		
60	1		27028			27228	
	1.25	27029			27229		
75	1.25		27030			27230	
	1.5		27031			27231	
80	1.25		27032			27232	
	1.5		27033			27233	
100	1.5		27034	27011		27234	27211
	2.5		27035			27235	
125	1.5		27036	27013	27238	27236	27213
	2.5		27037	27014		27237	27214
	3.75		27038				
150	1.5		27039	27015		27239	27215
	2.5		27040	27016		27240	27216
	3.75		27041			27241	
200	1.5		27042	27017		27242	27217
	2.5		27043	27018		27243	27218
	3.75		27044	27019		27244	27219
250	2.5		27045	27020		27245	27220
	5		27046	27021		27246	27221
300	2.5		27048	27022		27248	27222
	5		27049	27023		27249	27223

Primary conductor	
Round conductor	Ø 21.0 mm
Transformer width	44 mm
Snap-on mounting	<b>Art.-no. 55013</b> see page 206
Sealed shutter	—
Copper tubes	see page 206

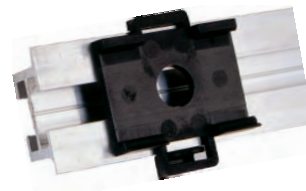


# ASR 21.3

Tube current transformer



Secondary current		5A	1A
Primary current A	Burden VA	Accuracy class	Accuracy class
		1	1
		Art.-no.	Art.-no.
100	1	1023	1223
150	1.5	1024	1224
200	1.5	1026	1226
	2.5	1027	1227
250	1.5	1028	1228
	2.5	1029	1229
	5	1030	1230
300	1.5	1031	1231
	2.5	1032	1232
	5	1033	1233
400	2.5	1034	1234
	5	1035	1235
	10	1036	1236
500	2.5	1037	1237
	5	1038	1238
	10	1039	1239
600	2.5	1040	1240
	5	1041	1241
	10	1042	1242



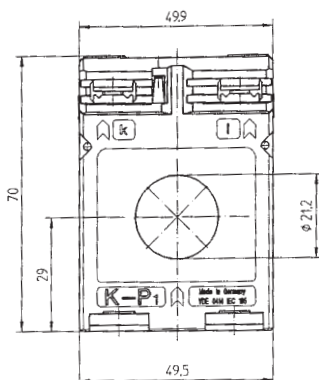
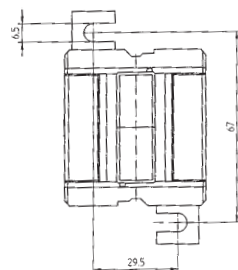
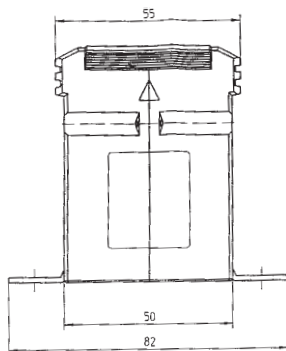
Snap-on mounting

Primary conductor	
Round conductor	$\phi 22.5$ mm
Transformer width	49.5 mm
Snap-on mounting	<b>Art.-no. 55014</b> see page 206
Sealed shutter	—
Copper tubes	see page 206



# ASR 21.5

## Tube current transformer



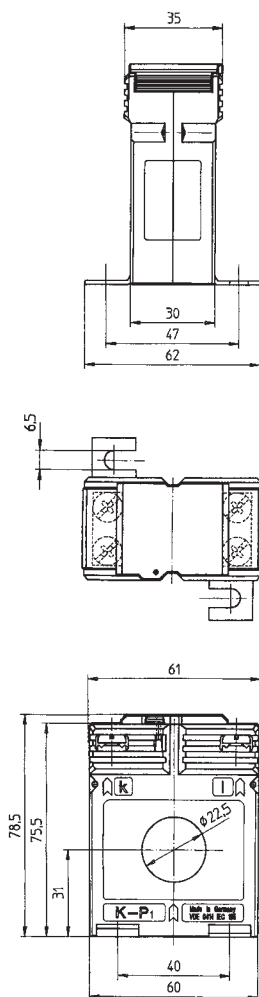
Secondary current		5A		1A	
Primary current A	Burden VA	Accuracy class		Accuracy class	
		1	0.5	1	0.5
		Art.-no.	Art.-no.	Art.-no.	Art.-no.
50	1.5	93050	93011	93250	93211
	2.5	93051			
60	1.5	93052	93012	93252	93212
	2.5	93053		93253	
	3.75	93054		93254	
75	1.5	93055	93013	93255	93213
	2.5	93056		93256	
	3.75	93057		93257	
80	1.5	93058	93014	93258	93214
	2.5	93059		93259	
	5	93060		93260	
100	1.5	93061	93015	93261	93215
	2.5	93062	93016	93262	93216
	5	93063		93263	
125	1.5	93064	93017	93264	93217
	2.5	93065	93018	93265	93218
	5	93066		93266	
150	2.5	93067	93019	93267	93219
	5	93068	93020	93268	93220
	10	93069		93269	
200	2.5	93070	93021	93270	93221
	5	93071	93022	93271	93222
	10	93072	93023	93272	93223
	15	93073		93273	
250	2.5	93074	93024	93274	93224
	5	93075	93025	93275	93225
	10	93076	93026	93276	93226
	15	93077		93277	
300	2.5	93078	93027	93278	93227
	5	93079	93028	93279	93228
	10	93080	93029	93280	93229
	15	93081	93030	93281	93230
400	2.5	93082	93031	93282	93231
	5	93083	93032	93283	93232
	10	93084	93033	93284	93233
	15	93085	93034	93285	93234
500	2.5	93086	93035	93286	93235
	5	93087	93036	93287	93236
	10	93088	93037	93288	93237
	15	93089	93038	93289	93238
600	2.5	93090	93039	93290	93239
	5	93091	93040	93291	93240
	10	93092	93041	93292	93241
	15	93093	93042	93293	93242

Primary conductor	
Round conductor	Ø 21.0 mm
Transformer width	50 mm
Snap-on mounting	—
Sealed shutter	—
Copper tubes	see page 206



# ASR 22.3

Tube current transformer



Secondary current		5A			1A	
Primary current A	Burden VA	Accuracy class			Accuracy class	
		1	0.5	0.2s	1	0.5
		Art.-no.	Art.-no.	Art.-no.	Art.-no.	Art.-no.
40	1	3034			3234	
50	1	3035			3235	
	1.5	3036			3236	
60	1	3037			3237	
	1.5	3038			3238	
75	1.5	3039			3239	
	2.5	3040			3240	
80	1.5	3041			3241	
	2.5	3042			3242	
100	1.5	3043	3011		3243	3211
	2.5	3044	3134		3244	3334
	3.75	3045			3245	
150	1.5	3046	3012	V04-1604C	3246	3212
	2.5	3047	3013	V04-1604D	3247	3213
	5	3048	3138		3248	3338
200	1.5		3014			3214
	2.5	3049	3015	V04-1704D	3249	3215
	5	3050	3016	V04-1704F	3250	3216
	10	3051			3251	
250	1.5		3017			3217
	2.5	3052	3018	V04-1804D	3252	3218
	5	3053	3019	V04-1804F	3253	3219
	10	3054	3020		3254	3220
	15	3055			3255	
300	2.5	3056	3022	V04-1904D	3256	3222
	5	3057	3023	V04-1904F	3257	3223
	10	3058	3024		3258	3224
	15	3059			3259	
400	2.5	3060	3025	V04-2004D	3260	3225
	5	3061	3026	V04-2004F	3261	3226
	10	3062	3027		3262	3227
	15	3063			3263	
500	2.5	3064	3028	V04-2104D	3264	3228
	5	3065	3029	V04-2104F	3265	3229
	10	3066	3030	V04-2104H	3266	3230
	15	3067			3267	
600	2.5	3068	3031	V04-2204D	3268	3231
	5	3069	3032	V04-2204F	3269	3232
	10	3070	3033	V04-2204H	3270	3233
	15	3071			3271	

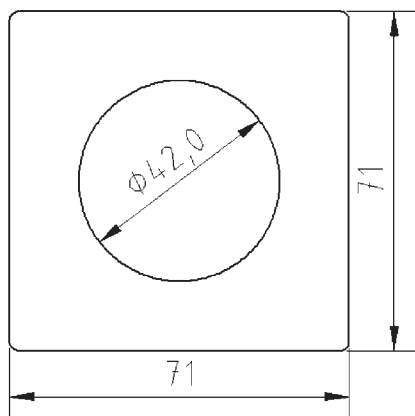
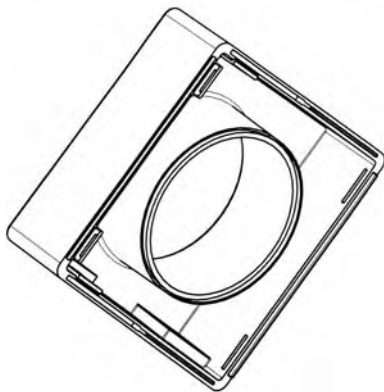
# ASR 22.3 2u

Primary conductor	
Round conductor	Ø 22.5 mm
Transformer width	61 mm
Snap-on mounting	<b>Art.-no. 53011</b> see page 206
Sealed shutter	<b>Art.-no. 59040</b> see page 207
Copper tubes	see page 206
Protection tube current transformer	see page 127
Current transformer for tariff applications	see page 169

Secondary current		5A	1A
Primary current A	Burden VA	Accuracy class	Accuracy class
		1	1
		Art.-no.	Art.-no.
200-100	5-2.5	3111	3311
300-150	5-2.5	3112	3312
	10-5	3113	3313
400-200	5-2.5	3114	3314
	10-5	3115	3315
500-250	5-2.5	3116	3316
	10-5	3117	3317
600-300	5-2.5	3118	3318
	10-5	3119	3319

# ASR 42.45

## Tube current transformer



Secondary current		5A	1A
Primary current A	Burden VA	Accuracy class	Accuracy class
		1	1
		Art.-no.	Art.-no.
150	1.5	26500	26600
	2.5	26501	26601
200	1.5	26502	26602
	2.5	26503	26603
	5	26504	26604
250	1.5	26505	26605
	2.5	26506	26606
	5	26507	26607
	7.5	26508	26608
300	2.5	26509	26609
	5	26510	26610
	10	26511	26611
400	2.5	26512	26612
	5	26513	26613
	10	26514	26614
500	2.5	26515	26615
	5	26516	26616
	10	26517	26617
	15	26518	26618
600	2.5	26519	26619
	5	26520	26620
	10	26521	26621
	15	26522	26622
750	2.5	26523	26623
	5	26524	26624
	10	26525	26625
	15	26526	26626
800	5	26527	26627
	10	26528	26628
	15	26529	26629
	30	26530	26630
1000	5	26531	26631
	10	26532	26632
	15	26533	26633
	30	26534	26634

Connection cable 2.5 mm<sup>2</sup>, 400 mm long.

The wire ends are complete with multi-bush wire ends.

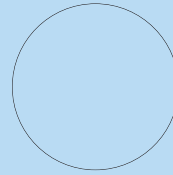
Primary conductor	
Round conductor	Ø 42 mm
Transformer width	71 mm
Transformer depth	45 mm
Snap-on mounting	—
Sealed shutter	—

# Tube current transformers

## ASG 210.3

resin hardened

Round conductor  
Transformer width



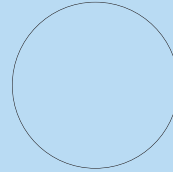
Ø 21 mm  
44 mm

## ASG 106

**NEW**

resin hardened

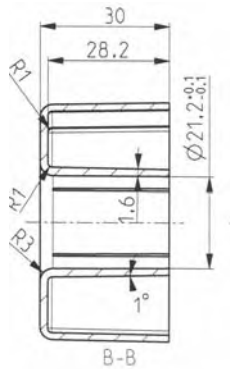
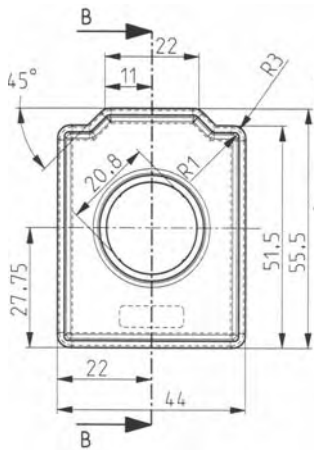
Round conductor  
Transformer width



Ø 106 mm  
190 mm

# ASG 210.3

Tube current transformer  
resin hardened



Secondary current		5A		1A	
Primary current A	Burden VA	Accuracy class		Accuracy class	
		3	1	3	1
		Art.-no.	Art.-no.	Art.-no.	Art.-no.
50	1	27500		27600	
60	1		27501		27601
	1.25	27502		27602	
75	1.25		27503		27603
	1.5		27504		27604
80	1.25		27505		27605
	1.5		27506		27606
100	1.5		27507		27607
	2.5		27508		27608
125	1.5		27509		27609
	2.5		27510		27610
	3.75		27511		27611
150	1.5		27512		27612
	2.5		27513		27613
	3.75		27514		27614
200	1.5		27515		27615
	2.5		27516		27616
	5		27517		27617
250	2.5		27518		27618
	5		27519		27619
	7.5		27520		27620
300	2.5		27521		27621
	5		27522		27622
	7.5		27523		27623

Connection cable 2.5 mm<sup>2</sup>, 400 mm long.

Primary conductor	—
Round conductor	Ø 21 mm
Transformer width	44 mm
Snap-on mounting	—
Sealed shutter	—
Copper tubes	see page 206

# ASG 106

## Tube current transformer for panel boards



### Features/benefits

- tube current transformer with 1...3 measuring systems integrated in one housing
- rated voltage 0.72 kV / 3 kV
- primary current range 50 A ... 1250 A
- secondary currents 1 A or 5 A
- nominal burden 2.5 VA up to 30 VA
- accuracy classes 0.2 / 0.5 / 0.5s / 1 / 5P / 10P
- thermal nominal continuous current  $1.2 \times I_N$
- it is possible to integrate into one housing a combination of measuring transformers and protection transformers
- measuring systems with hardened Polyurethan resin
- reliable results under extreme mechanical and climatic conditions
- a choice of 4 types of housings with different depths to accommodate special demands
- reduction of external wiring by means of fixed flexible connection terminals

### Application

Current transformers of the type ASG 106 have been designed to cater for panel boards. Solidly installed flexible terminal connections as well as a large primary conductor opening with a 106 mm diameter, ensure a time saving and an easy assembly. The modular arrangement of the transformer make it possible to use a multiple of different types of current transformers in one housing.

### Technical data ASG 106

Type	Low voltage current transformer, single-phase		Short time excess current	1.5 x $I_N$ / 60 min
	Measuring system with Polyurethan resin, UL94-VO, hardened			2.0 x $I_N$ / 30 min
Housing material	ABS / UL94-VO		Thermal nominal short time current	$I_{TH} = 25 \text{ kA} / 3 \text{ sec.}$ (other values upon request)
Max. operating voltage $U_m$	0.72 kV		Nominal dynamic short time current	$I_{DYN} = 60 \times I_N, 1 \text{ sec; max. } 100 \text{ kA}$
Isolation test voltage	3 kV $U_{EFF.}$ ; 50 Hz; 1 min.		Temperature environmental range	$-5 \text{ }^\circ\text{C} < \vartheta < +60 \text{ }^\circ\text{C}$
Rated-held-short time alternating voltage (coil test)	3 kV		Max. permissible excess temperature of the primary current	70 $^\circ\text{C}$
Nominal rated frequency	50 Hz, other frequencies upon request		Isolation class	"E"
Secondary connection cable	flexible copper wire, 4.0 mm <sup>2</sup> , HO7V-K1X4, length 3.6 m		Climatic condition	suitable for tropical climates
Primary rated current intensity	50 ... 1250 A		Constant technical standards	DIN EN 60044/1 (issue 12/2003) DIN VDE 0414/1
Secondary rated current intensity	5 A or 1 A		Dimensions: b x h x d	190 x 190 x (50,100,170,214*) mm
Secondary rated assumed data burden	2.5 ... 15 VA	2.5 ... 30 VA	Primary conductor guide	diameter 106 mm
Accuracy classes	0.2    0.5    1			
	10P10 ... 30	5P10 ... 30		
Overload current limiting factor	FS 5 or FS 10			
Thermal continuous rated current intensity	$I_D = 1.2 \times I_N,$ other values upon request			

\* Depth dependent on the number and type of the chosen measuring system

# Low voltage current transformers for industrial applications

## Plug-in current transformers

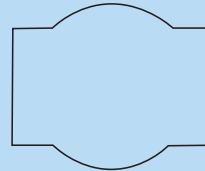
<b>AS 176.3</b>	Primary conductor Round conductor Transformer width		17 x 6 mm Ø 15 mm 45 mm
<b>ASK 176.3</b>	Primary conductor Round conductor Transformer width		17 x 6 mm Ø 15 mm 45 mm
<b>ASK 205.3</b>	Primary conductor Round conductor Transformer width		20 x 5 mm Ø 17.5 mm 49.5 mm
<b>ASK 21.3</b>	Primary conductor Round conductor Transformer width		20 x 10 mm Ø 19.2 mm 61 mm
<b>ASK 231.5</b>	Primary conductor Round conductor Transformer width		30 x 10 mm Ø 28 mm 50 mm
<b>ASK 31.3</b> <b>ASK 31.3 2u</b>	Primary conductor  Round conductor Transformer width		30 x 10 mm 2 x 20 x 10 mm Ø 26 mm 61 mm

# Low voltage current transformers for industrial applications

## Plug-in current transformers

### ASK 318.3

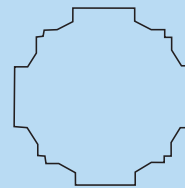
Primary conductor  
Round conductor  
Transformer width



31 x 18 mm  
Ø 26 mm  
61 mm

### ASK 31.4 ASK 31.4 2u ASK 31.4 3u

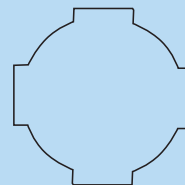
Primary conductor  
Round conductor  
Transformer width



30 x 10 mm  
2 x 20 x 10 mm  
Ø 28 mm  
61 mm

### ASK 31.5 ASK 31.5 2u

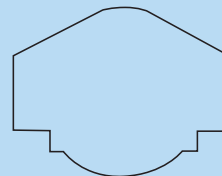
Primary conductor  
Round conductor  
Transformer width



30 x 10 mm  
2 x 20 x 10 mm  
Ø 28 mm  
61 mm

### ASK 31.6

Primary conductor  
Round conductor  
Transformer width



30 x 10 mm  
20 x 13 mm  
Ø 23 mm  
95 mm



# (E)AS 176.3

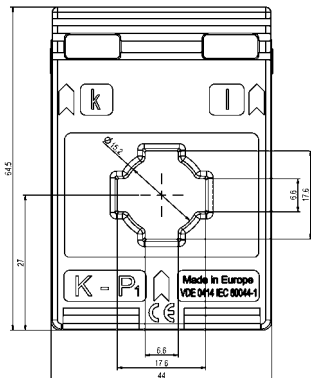
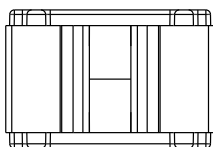
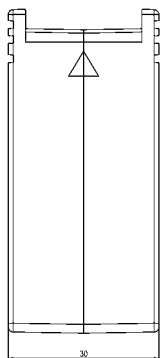
Plug-in current transformer

**AS 176.3 – industrial application**

Secondary current		5A			1A		
Primary current A	Burden VA	Accuracy class			Accuracy class		
		3	1	0.5	3	1	0.5
		Art.-no.	Art.-no.	Art.-no.	Art.-no.	Art.-no.	Art.-no.
75	1,5	1030007001			1030207001		
100	2		1030006001			1030206001	
125	2		1030006002			1030206002	
150	1,5			1030005001			1030205001
150	2,5		1030006003			1030206003	
160	2,5		1030006004			1030206004	
200	2,5		1030006005	1030005002		1030206005	1030205002
250	2,5			1030005003			1030205003
250	3,75		1030006006			1030206006	

**EAS 176.3 – tariff application**

150	1,5			1030505001			1030705001
200	2,5			1030505002			1030705002
250	3,75			1030505003			1030705003





# (E)ASK 176.3

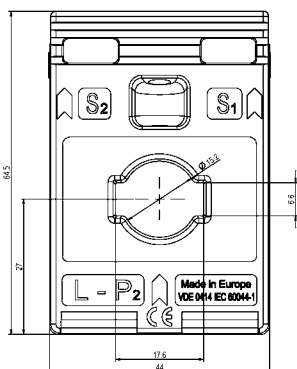
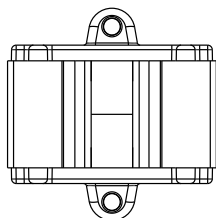
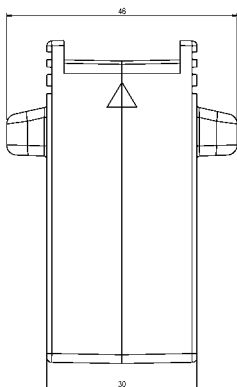
Plug-in current transformer

**ASK 176.3 – industrial application**

Secondary current		5A			1A		
Primary current A	Burden VA	Accuracy class			Accuracy class		
		3	1	0.5	3	1	0.5
		Art.-no.	Art.-no.	Art.-no.	Art.-no.	Art.-no.	Art.-no.
75	1,5	1020007001			1020207001		
100	2		1020006001			1020206001	
125	2		1020006002			1020206002	
150	1,5			1020005001			1020205001
150	2,5		1020006003			1020206003	
160	2,5		1020006004			1020206004	
200	2,5		1020006005	1020005002		1020206005	1020205002
250	2,5			1020005003			1020205003
250	3,75		1020006006			1020206006	

**EASK 176.3 – tariff application**

150	1,5			1020505001			1020705001
200	2,5			1020505002			1020705002
250	3,75			1030505003			1020705003

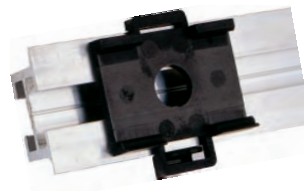
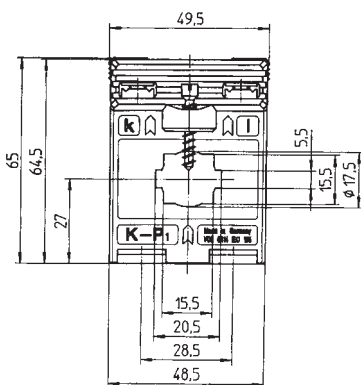
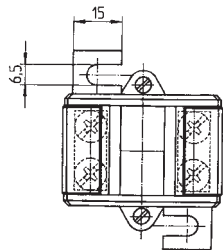
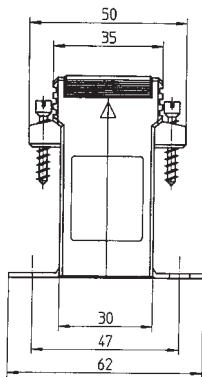




# ASK 205.3

Plug-in current transformer

Secondary current		5A	1A
Primary current A	Burden VA	Accuracy class	Accuracy class
		1	1
		Art.-no.	Art.-no.
60	1	2019	2219
75	1	2020	2220
80	1.25	2021	2221
	1.5	2023	2223
100	1.25	2022	2222
	1.5	2025	2225
150	1.5	2024	2224
	2.5	2025	2225
200	1.5	2026	2226
	2.5	2027	2227
250	2.5	2028	2228
	5	2029	2229
300	2.5	2030	2230
	5	2031	2231
400	2.5	2032	2232
	5	2033	2233
	10	2034	2234

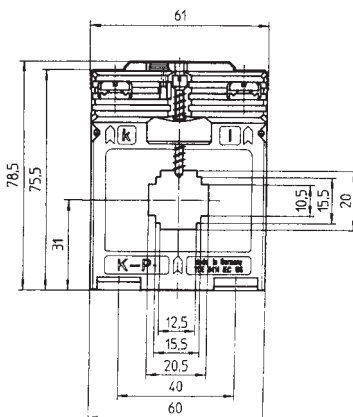
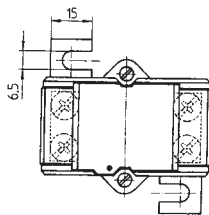
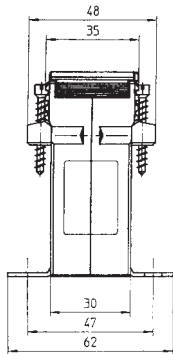


Snap-on mounting

Primary conductor	20 x 5 mm
Round conductor	Ø 17.5 mm
Transformer width	49.5 mm
Snap-on mounting	<b>Art.-no. 55014</b> see page 206
Sealed shutter	—

# ASK 21.3

## Plug-in current transformer

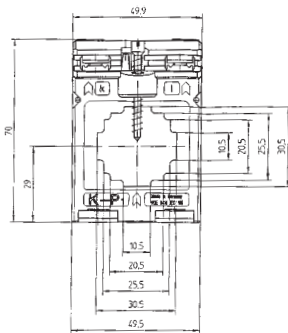
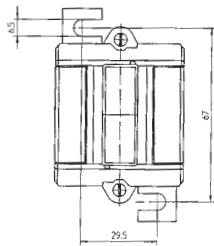
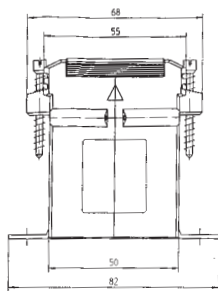


Secondary current		5A			1A	
Primary current A	Burden VA	Accuracy class			Accuracy class	
		1	0.5	0.2s	1	0.5
		Art.-no.	Art.-no.	Art.-no.	Art.-no.	Art.-no.
40	1	6034			6234	
50	1	6035			6235	
	1.5	6036			6236	
60	1	6037			6237	
	1.5	6038			6238	
75	1.5	6039			6239	
	2.5	6040			6240	
80	1.5	6041			6241	
	2.5	6042			6242	
100	1.5	6043	6011		6243	6211
	2.5	6044	6111		6244	6311
	3.75	6077			6277	
150	1.5	6046	6012	V10-1604C	6246	6212
	2.5	6047	6013	V10-1604D	6247	6213
	5	6048	6074		6248	6274
200	1.5		6014			6214
	2.5	6049	6015	V10-1704D	6249	6215
	5	6050	6016	V10-1704F	6250	6216
	10	6051			6251	
250	1.5		6017			6217
	2.5	6052	6018	V10-1804D	6252	6218
	5	6053	6019	V10-1804F	6253	6219
	10	6054	6020		6254	6220
	15	6055			6255	
300	2.5	6056	6022	V10-1904D	6256	6222
	5	6057	6023	V10-1904F	6257	6223
	10	6058	6024		6258	6224
	15	6059			6259	
400	2.5	6060	6025	V10-2004D	6260	6225
	5	6061	6026	V10-2004F	6261	6226
	10	6062	6027		6262	6227
	15	6063			6263	
500	2.5	6064	6028	V10-2104D	6264	6228
	5	6065	6029	V10-2104F	6265	6229
	10	6066	6030		6266	6230
	15	6067			6267	
600	2.5	6068	6031		6268	6231
	5	6069	6032		6269	6232
	10	6070	6033		6270	6233
	15	6071			6271	

Primary conductor	20 x 10 mm
Round conductor	Ø 19.2 mm
Transformer width	61 mm
Snap-on mounting	<b>Art.-no. 53011</b> see page 206
Sealed shutter	<b>Art.-no. 59040</b> see page 207
Protection plug-in current transformer	see page 128
Current transformer for tariff applications	see page 170

# ASK 231.5

Plug-in current transformer



Secondary current		5A		1A	
Primary current A	Burden VA	Accuracy class		Accuracy class	
		1	0,5	1	0,5
		Art.-no.	Art.-no.	Art.-no.	Art.-no.
50	1	92050		92250	
	1,25	92051		92251	
60	1	92052		92252	
	1,25	92053		92253	
75	1,25	92054		92254	
80	1,25	92056		92256	
100	1,5	92059		92259	
125	1,5	92062		92262	92220
150	1.5	92065		92265	92223
	2.5	92066		92266	
200	2.5	92068	92026	92268	92226
	5	92069		92269	
250	2.5	92071	92028	92271	92228
	5	92072	92029	92272	92229
300	2.5	92074	92030	92274	92230
	5	92075		92275	
400	2.5	92077	92032	92277	92232
	5	92078	92033	92278	92233
500	2.5	92081	92035	92281	92235
	5	92082	92036	92282	92236
	10	92083		92283	
600	2.5	92085	92038		
	5	92086	92039		
	10	92087			

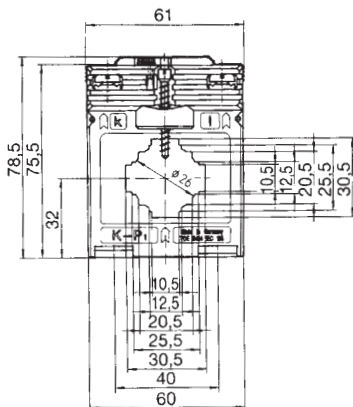
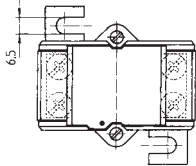
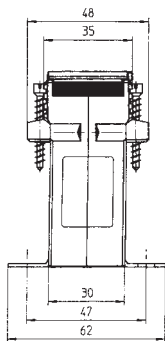
Primary conductor	30 x 10 mm
Round conductor	Ø 28.0 mm
Transformer width	50 mm
Snap-on mounting	—
Sealed shutter	—



# ASK 31.3

Plug-in current transformer

Secondary current		5A			1A	
Primary current A	Burden VA	Accuracy class			Accuracy class	
		1	0,5	0,2s	1	0,5
		Art.-no.	Art.-no.	Art.-no.	Art.-no.	Art.-no.
50	1	7038			7238	
60	1	7039			7239	
75	1	7040			7240	
	1.5	7041			7241	
80	1.5	7042			7242	
	2.5	7043			7243	
	2.5	7044	7011		7244	7211
100	2.5	7045	7012		7245	7212
	1.5	7046	7013	V11-1604C	7246	7213
150	2.5	7047	7014		7247	7214
	1.5	7048	7015		7248	7215
200	2.5	7049	7016	V11-1704D	7249	7216
	5	7050	7017		7250	7217
	1.5	7051	7018		7251	7218
250	2.5	7052	7019	V11-1804D	7252	7219
	5	7053	7020	V11-1804F	7253	7220
	10	7054			7254	
	1.5	7055	7021		7255	7221
300	2.5	7056	7022	V11-1904D	7256	7222
	5	7057	7023	V11-1904F	7257	7223
	10	7058			7258	7224
	1.5	7059			7259	
400	2.5	7060	7025	V11-2004D	7260	7225
	5	7061	7026	V11-2004F	7261	7226
	10	7062	7027		7262	7227
	2.5	7063	7028	V11-2104D	7263	7228
500	5	7064	7029	V11-2104F	7264	7229
	10	7065	7030		7265	7230
	2.5	7066	7031	V11-2204D	7266	7231
600	5	7067	7032	V11-2204F	7267	7232
	10	7068	7033		7268	7233
	15	7069	7034		7269	7234
	2.5	7070	7035	V11-2304D	7270	7235
750	5	7071	7036	V11-2304F	7271	7236
	10	7072	7037		7272	7237



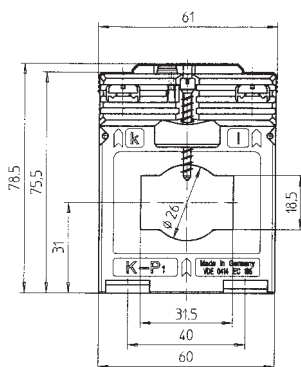
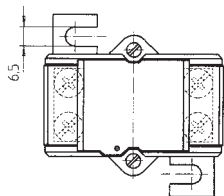
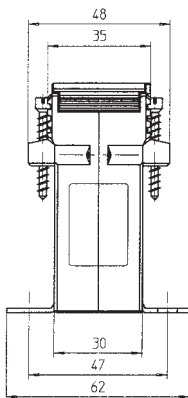
# ASK 31.3 2u

Primary conductor	30 x 10 mm 2 x 20 x 10 mm
Round conductor	Ø 26 mm
Transformer width	61 mm
Snap-on mounting	<b>Art.-no. 53011</b> see page 206
Sealed shutter	<b>Art.-no. 59040</b> see page 207
Current transformer for tariff applications	see page 171

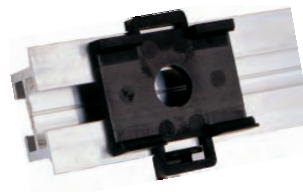
Secondary current		5A	1A
Primary current A	Burden VA	Accuracy class	Accuracy class
		1	1
		Art.-no.	Art.-no.
200-100	5-2.5	7111	7311
300-150	5-2.5	7112	7312
400-200	5-2.5	7113	7313
	10-5	7114	7314
	5-2.5	7115	7315
500-250	10-5	7116	7316
	10-5	7117	7317
600-300	15-7.5	7118	7318

# ASK 318.3

Plug-in current transformer



Secondary current		5A		1A	
Primary current A	Burden VA	Accuracy class		Accuracy class	
		1	0.5	1	0.5
		Art.-no.	Art.-no.	Art.-no.	Art.-no.
60	1	29042		29242	
75	1	29043		29243	
	1.5	29044		29244	
80	1.5	29045		29245	
	2.5	29046		29246	
100	1.5	29047	29011	29247	29211
	2.5	29048	29012	29248	29212
150	1.5	29049	29013	29249	29213
	2.5	29050	29014	29250	29214
200	2.5	29052	29016	29252	29216
	5	29053	29017	29253	29217
250	2.5	29055	29019	29255	29219
	5	29056	29020	29256	29220
	10	29057		29257	
300	2.5	29059	29023	29259	29223
	5	29060	29024	29260	29224
	10	29061		29261	
400	2.5	29063	29027	29263	29227
	5	29064	29028	29264	29228
	10	29065	29029	29265	29229
500	2.5	29066	29030	29266	29230
	5	29067	29031	29267	29231
	10	29068	29032	29268	29232
600	2.5	29069	29033	29269	29233
	5	29070	29034	29270	29234
	10	29071	29035	29271	29235
	15	29072	29036	29272	29236
750	2.5	29073	29037	29273	29237
	5	29074	29038	29274	29238
	10	29075	29039	29275	29239
	15	29076	29040	29276	29240

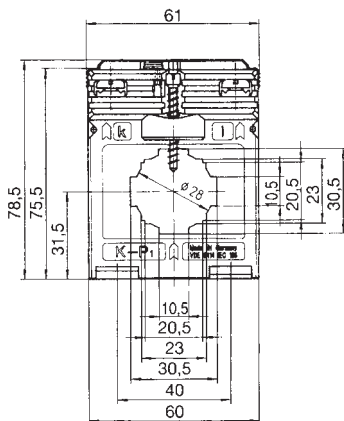
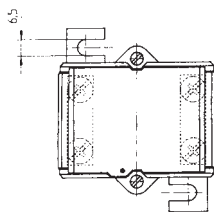
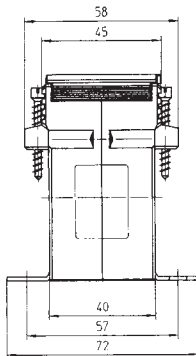


Snap-on mounting

Primary conductor	31 x 18 mm
Round conductor	Ø 26.0 mm
Transformer width	61 mm
Snap-on mounting	<b>Art.-no. 53011</b> see page 206
Sealed shutter	<b>Art.-no. 59040</b> see page 207

# ASK 31.4

## Plug-in current transformer



Primary conductor	30 x 10 mm 2 x 20 x 10 mm
Round conductor	Ø 28 mm
Transformer width	61 mm
Snap-on mounting	<b>Art.-no. 54011</b> see page 206
Sealed shutter	<b>Art.-no. 59041</b> see page 207
Current transformer for tariff applications	see page 172

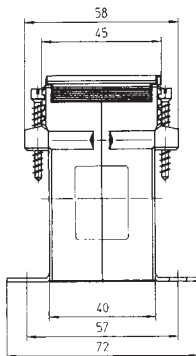
Secondary current		5A			1A	
Primary current A	Burden VA	Accuracy class			Accuracy class	
		1	0.5	0.2s	1	0.5
		Art.-no.	Art.-no.	Art.-no.	Art.-no.	Art.-no.
50	1.25	8157			8357	
	1.5	8038			8238	
60	1.25	8158			8358	
	1.5	8039			8239	
75	1.5	8041			8241	
	2.5	8042			8242	
80	1.5	8043			8243	
	2.5	8044			8244	
100	1.5	8045	8011		8245	8211
	2.5	8046	8010		8246	8210
	3.75	8152			8276	
150	1.5	8048	8012	V14-1604C	8248	8212
	2.5	8049	8013	V14-1604D	8249	8213
	5	8050	8410		8250	
200	2.5	8052	8014	V14-1704D	8252	8214
	5	8053	8015	V14-1704F	8253	8215
	10	8054			8254	
250	2.5	8055	8016	V14-1804D	8255	8216
	5	8056	8017	V14-1804F	8256	8217
	10	8057			8257	
	15	8058			8258	
300	2.5	8059	8018	V14-1904D	8259	8218
	5	8060	8019	V14-1904F	8260	8219
	10	8061	8020		8261	8220
	15	8062			8262	
400	2.5	8063	8021	V14-2004D	8263	8221
	5	8064	8022	V14-2004F	8264	8222
	10	8065	8023		8265	8223
	15	8066			8266	8224
500	2.5	8067	8025	V14-2104D	8267	8225
	5	8068	8026	V14-2104F	8268	8226
	10	8069	8027		8269	8227
	15	8070			8270	8228
600	2.5	8071	8029	V14-2204D	8271	8229
	5	8072	8030	V14-2204F	8272	8230
	10	8073	8031	V14-2204H	8273	8231
	15	8074	8032		8274	8232
750	2.5	8153	8033	V14-2304D	8353	8233
	5	8154	8034	V14-2304F	8354	8234
	10	8155	8035	V14-2304H	8355	8235
	15	8156	8036		8356	8236

Secondary change-over transformers see page 50.

Continuation from page 49

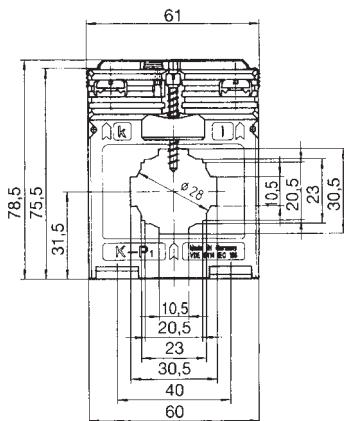
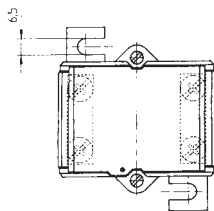
# ASK 31.4 2u

Plug-in secondary change-over current transformer

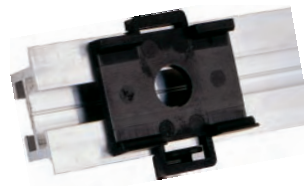


Secondary current		5A	1A
Primary current A	Burden VA	Accuracy class	Accuracy class
		1	1
		Art.-no.	Art.-no.
200-100	5-2.5	8117	8317
	10-5	8119	8319
300-150	5-2.5	8118	8318
	10-5	8121	8321
400-200	5-2.5	8120	8320
	10-5	8122	8322
500-250	5-2.5	8122	8322
	10-5	8123	8323
600-300	5-2.5	8124	8324
	10-5	8125	8325
	15-7.5	8126	8326

# ASK 31.4 3u



Secondary current		5A	1A
Primary current A	Burden VA	Accuracy class	Accuracy class
		1	1
		Art.-no.	Art.-no.
300-200-100	10-5-2.5	8137	8337
400-200-100	10-5-2.5	8138	8338
600-300-150	10-5-2.5	8139	8339
	15-10-5	8140	8340
600-400-200	10-5-2.5	8141	8341
	15-10-5	8142	8342



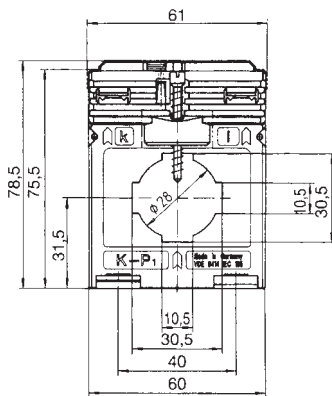
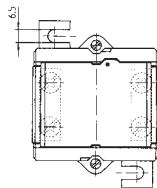
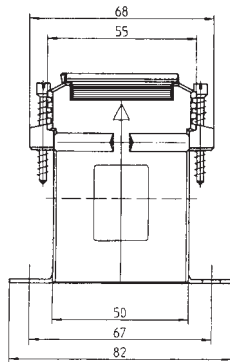
Snap-on mounting

Primary conductor	30 x 10 mm 2 x 20 x 10 mm
Round conductor	Ø 28 mm
Transformer width	61 mm
Snap-on mounting	<b>Art.-no. 54011</b> see page 206
Sealed shutter	<b>Art.-no. 59041</b> see page 207
Current transformer for tariff applications	see page 172



# ASK 31.5

Plug-in current transformer



Primary conductor	30 x 10 mm 2 x 20 x 10 mm
Round conductor	Ø 28 mm
Transformer width	61 mm
Snap-on mounting	<b>Art.-no. 55011</b> see page 206
Sealed shutter	<b>Art.-no. 59041</b> see page 207
Protection plug-in current transformer	see page 129
Current transformer for tariff applications	see page 173

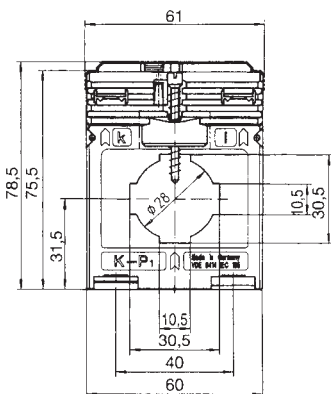
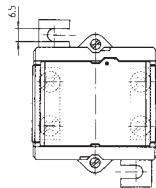
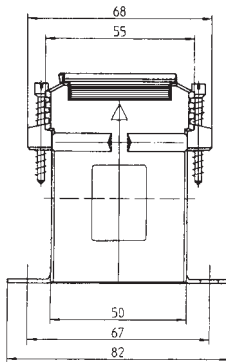
Secondary current		5A		1A	
Primary current A	Burden VA	Accuracy class		Accuracy class	
		1	0.5	1	0.5
		Art.-no.	Art.-no.	Art.-no.	Art.-no.
40	1	9043		9243	
50	1.5	9045		9245	
	2.5	9046		9246	
60	1.5	9047		9247	
	2.5	9048		9248	
75	1.5	9049	9011	9249	9211
	2.5	9050	9012	9250	9212
80	1.5	9051	9013	9251	9213
	2.5	9052	9014	9252	9214
100	1.5	9054	9015	9254	9215
	2.5	9055	9016	9255	9216
	5	9056	9017	9256	9217
150	2.5	9057	9018	9257	9218
	5	9058	9019	9258	9219
	7.5	9059		9259	
200	2.5	9060	9020	9260	9220
	5	9061	9021	9261	9221
	10	9062	9022	9262	9222
	15	9063		9263	
250	5	9064	9023	9264	9223
	10	9065	9024	9265	9224
	15	9066	9025	9266	9225
300	5	9067	9026	9267	9226
	10	9068	9027	9268	9227
	15	9069	9028	9269	9228
400	5	9070	9029	9270	9229
	10	9071	9030	9271	9230
	15	9072	9031	9272	9231
	30	9073		9273	
500	5	9074	9032	9274	9232
	10	9075	9033	9275	9233
	15	9076	9034	9276	9234
	30	9077		9277	
600	5	9078	9035	9278	9235
	10	9079	9036	9279	9236
	15	9080	9037	9280	9237
	30	9081		9281	
750	5	9082	9038	9282	9238
	10	9083	9039	9283	9239
	15	9084	9040	9284	9240
	30	9085		9285	

Secondary change-over transformers see page 52.

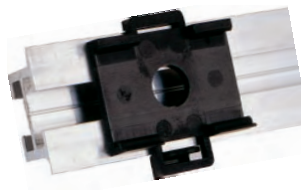
Continuation from page 51

# ASK 31.5 2u

Plug-in secondary change-over current transformer



Secondary current		5A	1A
Primary current A	Burden VA	Accuracy class	Accuracy class
		1	1
		Art.-no.	Art.-no.
150-75	5-2.5	9132	9332
	10-5	9134	9334
200-100	5-2.5	9133	9333
	10-5	9136	9336
	15-7.5	9137	9337
300-150	5-2.5	9135	9335
	10-5	9138	9338
	15-7.5	9139	9339
400-200	5-2.5	9140	9340
	10-5	9141	9341
	15-7.5	9142	9342
500-250	5-2.5	9143	9343
	10-5	9144	9344
	15-7.5	9145	9345
600-300	5-2.5	9146	9346
	10-5		
	15-7.5		



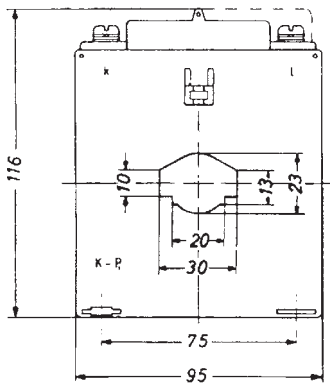
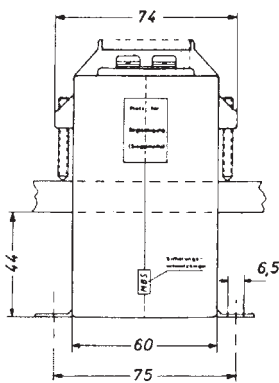
Snap-on mounting

Primary conductor	30 x 10 mm 2 x 20 x 10 mm
Round conductor	Ø 28 mm
Transformer width	61 mm
Snap-on mounting	<b>Art.-no. 55011</b> see page 206
Sealed shutter	<b>Art.-no. 59041</b> see page 207
Protection plug-in current transformer	see page 129
Current transformer for tariff applications	see page 173



# ASK 31.6

Plug-in current transformer

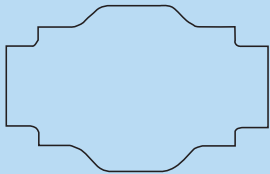
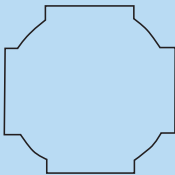
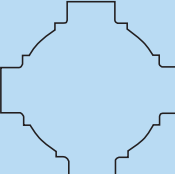
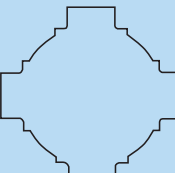
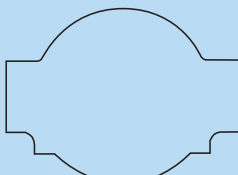
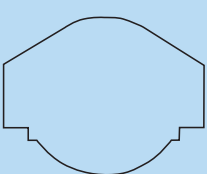


Primary conductor	30 x 10 mm 20 x 13 mm
Round conductor	Ø 23 mm
Transformer width	95 mm
Snap-on mounting	—
Sealed shutter	<b>Art.-no. 59044</b> see page 207
Protection plug-in current transformer	see page 130
Current transformer for tariff applications	see page 174

Secondary current		5A		1A	
Primary current A	Burden VA	Accuracy class		Accuracy class	
		1	0.5	1	0.5
		Art.-no.	Art.-no.	Art.-no.	Art.-no.
30	1.5	10054		10254	
40	1.5	10056		10256	
	2.5	10057		10257	
	1.5		10011		10211
50	2.5	10058	10012	10258	10212
	1.5		10013		10213
60	2.5	10059	10014	10259	10214
	3.75	10060		10260	
	2.5		10015		10215
75	5	10062	10016	10262	10216
	2.5	10061		10261	
80	5	10063	10017	10263	10217
	10	10064	10018	10264	10218
	10	10065		10265	
100	2.5	10066	10019	10266	10219
	5	10067	10020	10267	10220
	10	10068	10021	10268	10221
	15	10069		10269	
150	2.5		10022		10222
	5	10070	10023	10270	10223
	10	10071	10024	10271	10224
	15	10072	10025	10272	10225
200	2.5		10026		10226
	5	10073	10027	10273	10227
	10	10074	10028	10274	10228
	15	10075	10029	10275	10229
250	5	10076	10030	10276	10230
	10	10077	10031	10277	10231
	15	10078	10032	10278	10232
300	5	10079	10034	10279	10234
	10	10080	10035	10280	10235
	15	10081	10036	10281	10236
400	5	10082	10038	10282	10238
	10	10083	10039	10283	10239
	15	10084	10040	10284	10240
500	5	10085	10042	10285	10242
	10	10086	10043	10286	10243
	15	10087	10044	10287	10244
600	5	10088	10046	10288	10246
	10	10089	10047	10289	10247
	15	10090	10048	10290	10248
750	5	10091	10050	10291	10250
	10	10092	10051	10292	10251
	15	10093	10052	10293	10252



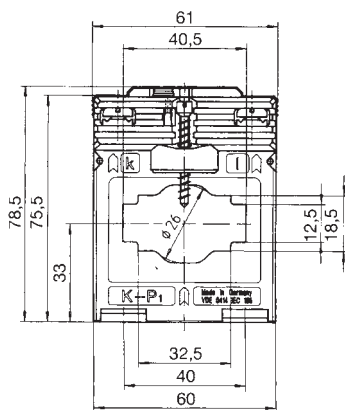
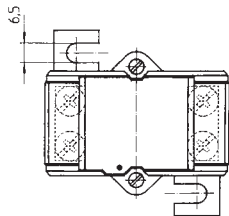
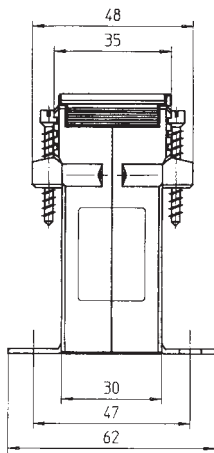
# Plug-in current transformers

<b>ASK 41.3</b>	Primary conductor		40 x 12 mm
	Round conductor		32 x 18 mm
	Transformer width		Ø 26 mm 61 mm
<b>ASK 421.4</b>	Primary conductor		20 x 10 mm
	Round conductor		Ø 20 mm
	Transformer width		71 mm
<b>ASK 41.4</b> <b>ASK 41.4 2u</b> <b>ASK 41.4 3u</b>	Primary conductor		40 x 10 mm
	Round conductor		2 x 30 x 5 mm Ø 32 mm
	Transformer width		71 mm
<b>ASK 41.5</b>	Primary conductor		40 x 10 mm
	Round conductor		Ø 32 mm
	Transformer width		71 mm
<b>ASK 412.4</b> <b>ASK 412.4 2u</b> <b>ASK 412.4 3u</b>	Primary conductor		40 x 12 mm
	Round conductor		30 x 15 mm Ø 30.5 mm
	Transformer width		71 mm
<b>ASK 41.6</b>	Primary conductor		40 x 12 mm
	Round conductor		30 x 15 mm Ø 32 mm
	Transformer width		95 mm

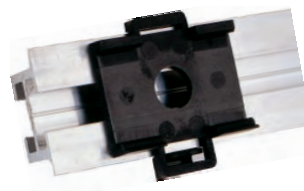


# ASK 41.3

Plug-in current transformer



Secondary current		5A	1A
Primary current A	Burden VA	Accuracy class	Accuracy class
		1	1
		Art.-no.	Art.-no.
100	1	11037	11237
	1.5	11038	11238
150	1.5	11039	11239
	2.5	11040	11240
200	1.5	11041	11241
	2.5	11042	11242
250	1.5	11043	11243
	2.5	11044	11244
	5	11045	11245
300	1.5	11046	11246
	2.5	11047	11247
	5	11048	11248
400	1.5	11049	
	2.5	11050	
	5	11051	
500	1.5	11052	
	2.5	11053	
	5	11054	
	10	11055	
600	1.5	11056	
	2.5	11057	
	5	11058	
	10	11059	
750	2.5	11060	
	5	11061	
	10	11062	
	15	11063	
800	2.5	11064	
	5	11065	
	10	11066	
	15	11067	



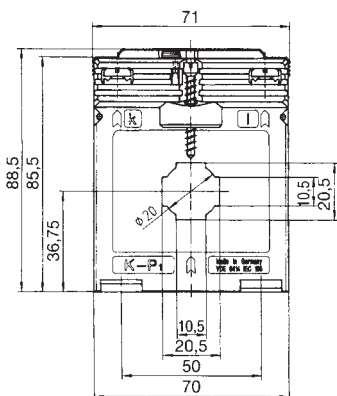
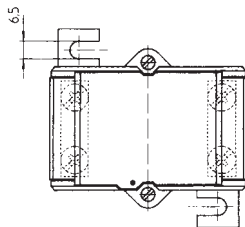
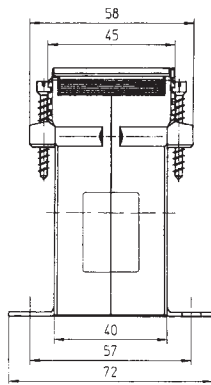
Snap-on mounting

Primary conductor	40 x 12 mm 32 x 18 mm
Round conductor	Ø 26.0 mm
Transformer width	61 mm
Snap-on mounting	<b>Art.-no. 53011</b> see page 206
Sealed shutter	<b>Art.-no. 59040</b> see page 207



# ASK 421.4

Plug-in current transformer

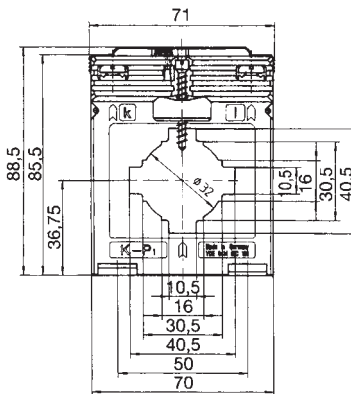
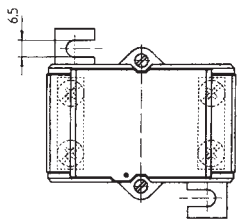
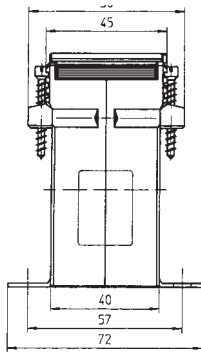


Secondary current		5A			1A		
Primary current A	Burden VA	Accuracy class			Accuracy class		
		3	1	0.5	3	1	0.5
		Art.-no.	Art.-no.	Art.-no.	Art.-no.	Art.-no.	Art.-no.
30	1	12052			12252		
40	1.5		12034			12234	
50	1.5		12035	12011		12235	12211
	2.5		12036			12236	
60	1.5		12037	12012		12237	12212
	2.5		12038			12238	
	3.75		12039			12239	
75	2.5		12040	12013		12240	12213
	5		12041			12241	
80	2.5		12042	12014		12242	12214
	5		12043			12243	
100	2.5		12044	12015		12244	12215
	5		12045	12016		12245	12216
	10		12046			12246	
125	2.5		12047	12017		12247	12217
	5		12048	12018		12248	12218
	10		12049			12249	
150	2.5			12019			12219
	5		12050	12020		12250	12220
	10		12051			12251	
200	2.5			12021			12221
	5		12053	12022		12253	12222
	10		12054			12254	
	15		12055			12255	
250	5		12056	12023		12256	12223
	10		12057	12024		12257	12224
	15		12058			12258	
300	5		12059	12025		12259	12225
	10		12060	12026		12260	12226
	15		12061			12261	
400	5			12027			12227
	10		12062	12028		12262	12228
	15		12063	12029		12263	12229
	30		12064			12264	
500	5			12030			12230
	10		12065	12031		12265	12231
	15		12066	12032		12266	12232
	30		12067			12267	

Primary conductor	20 x 10 mm
Round conductor	Ø 20 mm
Transformer width	71 mm
Snap-on mounting	—
Sealed shutter	<b>Art.-no. 59041</b> see page 207
Protection plug-in current transformers	see page 134

# ASK 41.4

## Plug-in current transformer



Primary conductor	40 x 10 mm 2 x 30 x 5 mm
Round conductor	Ø 32 mm
Transformer width	71 mm
Snap-on mounting	<b>Art.-no. 55012</b> see page 206
Sealed shutter	<b>Art.-no. 59041</b> see page 207
Protection plug-in current transformer	see page 135
Current transformer for tariff applications	see page 176

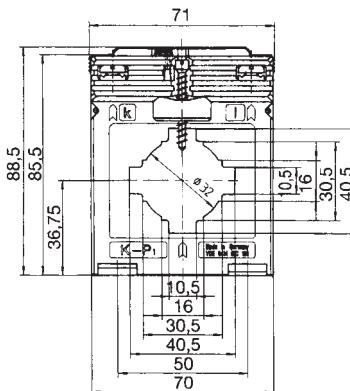
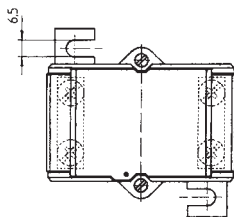
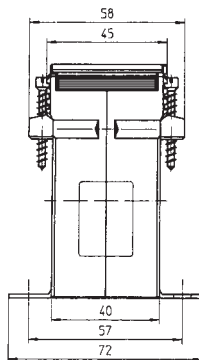
Secondary current		5A			1A	
Primary current A	Burden VA	Accuracy class			Accuracy class	
		1	0.5	0.2s	1	0.5
		Art.-no.	Art.-no.	Art.-no.	Art.-no.	Art.-no.
50	1.25	13180			13380	
	1.5	13036			13236	
60	1.25	13181			13238	
	1.5	13037			13237	
75	1.5	13039			13239	
	2.5	13040			13240	
80	1.5	13041			13241	
	2.5	13042			13242	
100	1.5	13043	13011		13243	13211
	2.5	13044	13083		13244	13283
	3.75	13179			13245	
150	1.5	13046	13012	V24-1604C	13246	13212
	2.5	13047	13013	V24-1604D	13247	13213
	5	13048	13084		13248	13284
200	1.5		13014	V24-1704C		13214
	2.5	13049	13015	V24-1704D	13249	13215
	5	13050	13085	V24-1704F	13250	13285
	10	13051			13251	
250	1.5		13016			13216
	2.5	13052	13017	V24-1804D	13252	13217
	5	13053	13086	V24-1804F	13253	13286
	10	13054			13254	
300	2.5	13055	13018	V24-1904D	13255	13218
	5	13056	13019	V24-1904F	13256	13219
	10	13057	13087		13257	13287
	15	13058			13258	
400	2.5	13059	13020	V24-2004D	13259	13220
	5	13060	13021	V24-2004F	13260	13221
	10	13061	13088	V24-2004H	13261	13288
	15	13062			13262	
500	2.5	13063	13022	V24-2104D	13263	13222
	5	13064	13023	V24-2104F	13264	13223
	10	13065	13024	V24-2104H	13265	13224
	15	13066	13089		13266	13289
600	2.5	13067	13025	V24-2204D	13267	13225
	5	13068	13026	V24-2204F	13268	13226
	10	13069	13027		13269	13227
	15	13070	13090		13270	13290
750	2.5			V24-2304D		
	5	13071	13028	V24-2304F	13271	13228
	10	13072	13029	V24-2304H	13272	13229
800	15	13073	13091		13273	13291
	5	13075	13030		13275	13230
	10	13076	13031		13276	13231
1000	15	13077			13277	
	30	13078			13278	
	5	13079	13032		13279	13232
	10	13080	13033		13280	13233
	15	13081	13034		13281	13234
	30	13082			13282	

Secondary change-over transformers see page 59.

Continuation from page 58

# ASK 41.4 2u

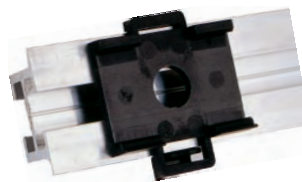
Plug-in secondary change-over current transformer



Secondary current		5A	1A
Primary current A	Burden VA	Accuracy class	Accuracy class
		1	1
		Art.-no.	Art.-no.
200-100	5-2.5	13133	13333
	10-5	13134	13334
300-150	5-2.5	13135	13335
	10-5	13136	13336
400-200	5-2.5	13137	13337
	10-5	13138	13338
500-250	5-2.5	13139	13339
	10-5	13140	13340
600-300	5-2.5	13141	13341
	10-5	13177	13342
800-400	5	13142	13343
	5-2.5	13143	13344
	10-5	13144	13344
1000-500	15-7.5	13145	13345
	5-2.5	13146	13346
	10-5	13147	13347

# ASK 41.4 3u

Secondary current		5A	1A
Primary current A	Burden VA	Accuracy class	Accuracy class
		1	1
		Art.-no.	Art.-no.
400-200-100	10-5-2.5	13163	13363
600-300-150	10-5-2.5	13164	13364
800-400-200	10-5-2.5	13165	13365
1000-500-250	10-5-2.5	13166	13366
	15-7.5-2.5	13167	13367



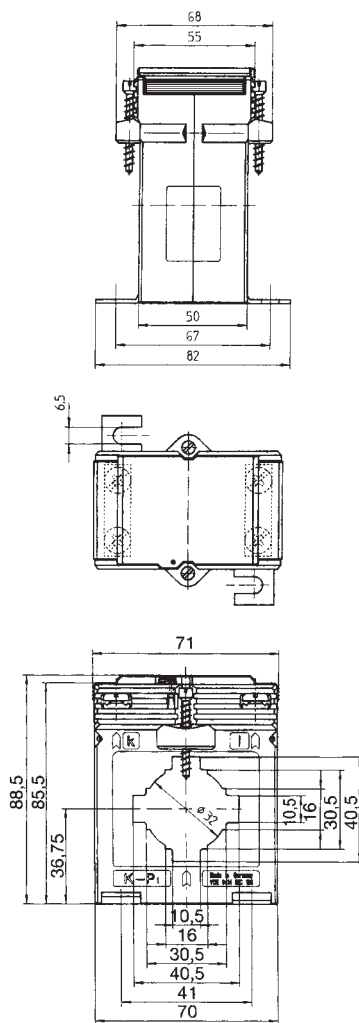
Snap-on mounting

Primary conductor	40 x 10 mm 2 x 30 x 5 mm
Round conductor	Ø 32 mm
Transformer width	71 mm
Snap-on mounting	<b>Art.-no. 55012</b> see page 206
Sealed shutter	<b>Art.-no. 59041</b> see page 207
Protection plug-in current transformer	see page 135
Current transformer for tariff applications	see page 176



# ASK 41.5

Plug-in current transformer

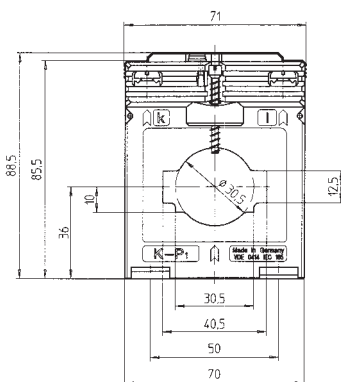
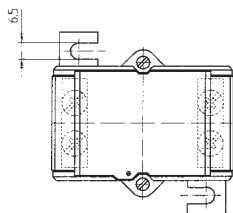
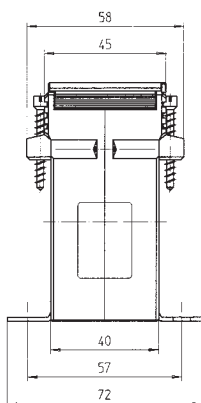


Secondary current		5A		1A	
Primary current A	Burden VA	Accuracy class		Accuracy class	
		1	0.5	1	0.5
		Art.-no.	Art.-no.	Art.-no.	Art.-no.
50	1,5	1010006001		1010206001	
60	1,5	1010006002		1010206002	
	2,5	1010006003		1010206003	
75	1,5	1010006004	1010005001	1010206004	1010205001
	2,5	1010006005	1010005002	1010206005	1010205002
80	1,5	1010006006	1010005003	1010206006	1010205003
	2,5	1010006007	1010005004	1010206007	1010205004
100	1,5	1010006008	1010005005	1010206008	1010205005
	2,5	1010006009	1010005006	1010206009	1010205006
	3,75			1010206010	
150	2,5	1010006010	1010005007	1010206011	1010205007
	5	1010006011	1010005008	1010206012	1010205008
	7,5	1010006012	1010005009	1010206013	1010205009
200	2,5	1010006013	1010005010	1010206014	1010205010
	5	1010006014	1010005011	1010206015	1010205011
	10			1010206016	1010205012
250	2,5	1010006015	1010005012	1010206017	1010205013
	5	1010006016	1010005013	1010206018	1010205014
	10	1010006017	1010005014	1010206019	1010205015
	15			1010206020	1010205016
300	2,5	1010006018	1010005015	1010206021	1010205017
	5	1010006019	1010005016	1010206022	1010205018
	10	1010006020	1010005017	1010206023	1010205019
	15	1010006021	1010005018	1010206024	1010205020
400	2,5	1010006022	1010005019	1010206025	1010205021
	5	1010006023	1010005020	1010206026	1010205022
	10	1010006024	1010005021	1010206027	1010205023
	15	1010006025	1010005022	1010206028	1010205024
500	2,5	1010006026	1010005023	1010206029	1010205025
	5	1010006027	1010005024	1010206030	1010205026
	10	1010006028	1010005025	1010206031	1010205027
	15	1010006029	1010005026	1010206032	1010205028
600	2,5	1010006030	1010005027	1010206033	1010205029
	5	1010006031	1010005028	1010206034	1010205030
	10	1010006032	1010005029	1010206035	1010205031
	15	1010006033	1010005030	1010206036	1010205032
750	2,5	1010006034	1010005031	1010206037	1010205033
	5	1010006035	1010005032	1010206038	1010205034
	10	1010006036	1010005033	1010206039	1010205035
	15	1010006037	1010005034	1010206040	1010205036
800	2,5	1010006038	1010005035	1010206041	1010205037
	5	1010006039	1010005036	1010206042	1010205038
	10	1010006040	1010005037	1010206043	1010205039
	15	1010006041	1010005038	1010206044	1010205040
1000	2,5	1010006042	1010005039	1010206045	1010205041
	5	1010006043	1010005040	1010206046	1010205042
	10	1010006044	1010005041	1010206047	1010205043
	15	1010006045	1010005042	1010206048	1010205044

Primary conductor	40 x 10 mm 2 x 30 x 5 mm
Round conductor	Ø 32 mm
Transformer width	71 mm
Snap-on mounting	<b>Art.-no. 55011</b> see page 206
Sealed shutter	<b>Art.-no. 59041</b> see page 207
Current transformer for tariff applications	see page 177

# ASK 412.4

## Plug-in current transformer



Primary conductor	40 x 12 mm 30 x 15 mm
Round conductor	Ø 30.5 mm
Transformer width	71 mm
Snap-on mounting	<b>Art.-no. 55012</b> see page 206
Sealed shutter	<b>Art.-no. 59041</b> see page 207

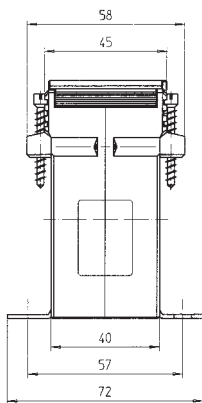
Secondary current		5A		1A	
Primary current A	Burden VA	Accuracy class		Accuracy class	
		1	0.5	1	0.5
		Art.-no.	Art.-no.	Art.-no.	Art.-no.
50	1.25	28036		28236	
	1.5	28037		28237	
60	1.25	28038		28238	
	1.5	28039		28239	
75	1.5	28040		28240	
	2.5	28041		28241	
80	1.5	28042		28242	
	2.5	28043		28243	
100	1.5	28044	28011	28244	28211
	2.5	28045		28245	
	3.75	28046		28246	
150	1.5	28047	28012	28247	28212
	2.5	28048	28013	28248	28213
	5	28049		28249	
200	2.5	28051	28015	28251	28215
	5	28052		28252	
	10	28053		28253	
250	1.5	28054	28016	28254	28216
	2.5	28055	28017	28255	28217
	5	28056	28014	28256	28214
	10	28057		28257	28087
300	2.5	28058	28018	28258	28218
	5	28059	28019	28259	28219
	10	28060		28260	
	15	28061		28261	
400	2.5	28062	28020	28262	28220
	5	28063	28021	28263	28221
	10	28064	28009	28264	28209
	15	28065		28265	
500	2.5	28066	28022	28266	28222
	5	28067	28023	28267	28223
	10	28068	28024	28268	28224
	15	28069		28269	
600	2.5	28070	28025	28270	28225
	5	28071	28026	28271	28226
	10	28072	28027	28272	28227
	15	28073		28273	
750	5	28074	28028	28274	28228
	10	28075	28029	28275	28229
	15	28076	28010	28276	28210
	30	28077		28277	
800	5	28078	28030	28278	28230
	10	28079	28031	28279	28231
	15	28080	28035	28280	28235
	30	28081		28281	

Secondary change-over transformers see page 62.

Continuation from page 61

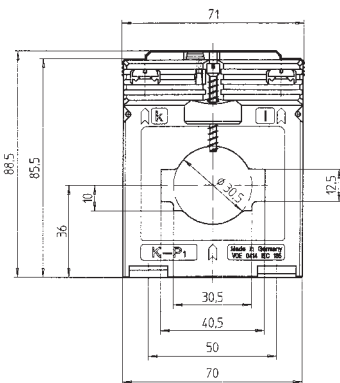
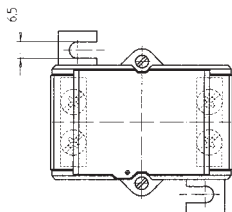
# ASK 412.4 2u

Plug-in secondary change-over current transformer

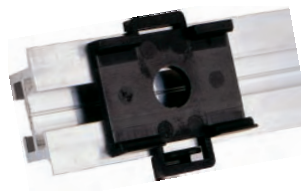


Secondary current		5A	1A
Primary current A	Burden VA	Accuracy class	Accuracy class
		1	1
		Art.-no.	Art.-no.
200-100	5-2.5	28133	28333
300-150	5-2.5	28134	28334
	10-5	28135	28335
400-200	5-2.5	28136	28336
	10-5	28137	28337
500-250	5-2.5	28138	28338
	10-5	28139	28339
600-300	5-2.5	28140	28340
	10-5	28141	28341
800-400	5-2.5	28143	28343
	10-5	28144	28344
	15-7.5	28145	28345

# ASK 412.4 3u



Secondary current		5A	1A
Primary current A	Burden VA	Accuracy class	Accuracy class
		1	1
		Art.-no.	Art.-no.
400-200-100	10-5-2.5	28163	28363
	15-7.5-2.5		
600-300-150	10-5-2.5	28164	28364
800-400-200	10-5-2.5	28165	28365



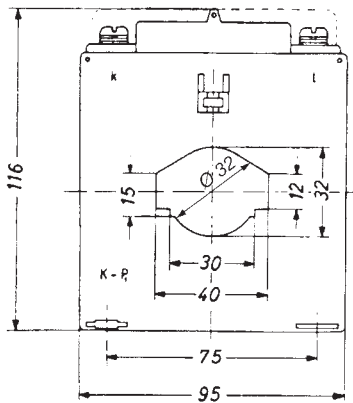
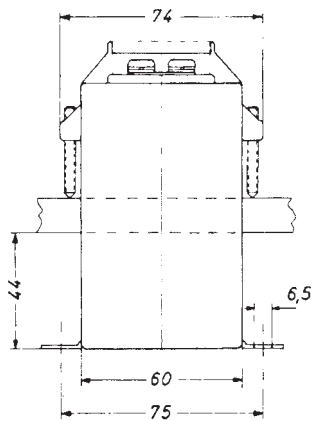
Snap-on mounting

Primary conductor	40 x 12 mm 30 x 15 mm
Round conductor	Ø 30.5 mm
Transformer width	71 mm
Snap-on mounting	<b>Art.-no. 55012</b> see page 206
Sealed shutter	<b>Art.-no. 59041</b> see page 207



# ASK 41.6

## Plug-in current transformer



Primary conductor	40 x 12 mm 30 x 15 mm
Round conductor	Ø 32 mm
Transformer width	95 mm
Snap-on mounting	—
Sealed shutter	<b>Art.-no. 59044</b> see page 207
Protection plug-in current transformer	see page 136
Current transformer for tariff applications	see page 178

Secondary current		5A		1A	
Primary current A	Burden VA	Accuracy class		Accuracy class	
		1	0.5	1	0.5
		Art.-no.	Art.-no.	Art.-no.	Art.-no.
50	1.5	14060	14011	14260	14211
	2.5	14061		14261	
60	1.5	14062	14012	14262	14212
	2.5	14063		14263	
75	1.5	14064		14264	
	2.5	14065	14013	14265	14213
	5	14066	14014	14266	14214
80	2.5	14067	14015	14267	14215
	5	14068	14016	14268	14216
100	2.5	14069	14017	14269	14217
	5	14070	14018	14270	14218
	10	14071	14019	14271	14219
150	2.5		14020		14220
	5	14072	14021	14272	14221
	10	14073	14022	14273	14222
	15	14074	14023	14274	14223
200	2.5		14024		14224
	5	14075	14025	14275	14225
	10	14076	14026	14276	14226
	15	14077	14027	14277	14227
250	2.5				14228
	5	14078	14029	14278	14229
	10	14079	14030	14279	14230
	15	14080	14031	14280	14231
300	2.5		14032		14232
	5	14081	14033	14281	14233
	10	14082	14034	14282	14234
	15	14083	14035	14283	14235
400	2.5		14036		14236
	5	14084	14037	14284	14237
	10	14085	14038	14285	14238
	15	14086	14039	14286	14239
500	2.5		14040		14240
	5	14087	14041	14287	14241
	10	14088	14042	14288	14242
	15	14089	14043	14289	14243
600	5		14044		14244
	10	14090	14045	14290	14245
	15	14091	14046	14291	14246
	30	14092	14047	14292	14247
750	5		14048		14248
	10	14094	14049	14294	14249
	15	14095	14050	14295	14250
	30	14096	14051	14296	14251
800	10	14098	14053	14298	14253
	15	14099	14054	14299	14254
	30	14100	14055	14300	14255
1000	5		14056		14256
	10	14102	14057	14302	14257
	15	14103	14058	14303	14258
	30	14104	14059	14304	14259
	45	14105		14305	



# Plug-in current transformers

## ASK 541.4

Primary conductor

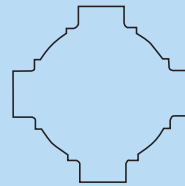
40 x 10 mm

Round conductor  
Transformer width

2 x 30 x 5 mm

Ø 32 mm

86 mm



## ASK 51.4

Primary conductor

50 x 12 mm

## ASK 51.4 2u

Round conductor

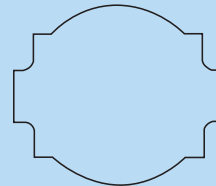
2 x 40 x 10 mm

Ø 44 mm

## ASK 51.4 3u

Transformer width

86 mm



## ASK 51.6

Primary conductor

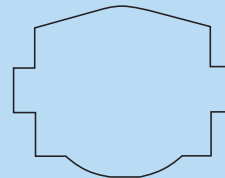
50 x 12 mm

Round conductor  
Transformer width

40 x 30 mm

Ø 40 mm

95 mm



## ASK 561.4

Primary conductor

60 x 10 mm

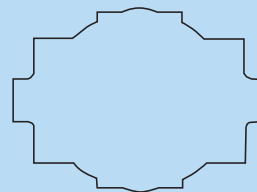
Round conductor  
Transformer width

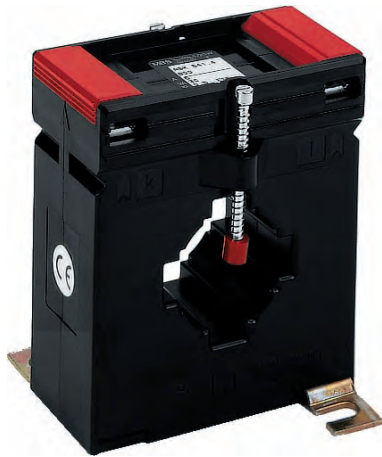
30 x 40 mm

2 x 50 x 10 mm

Ø 44 mm

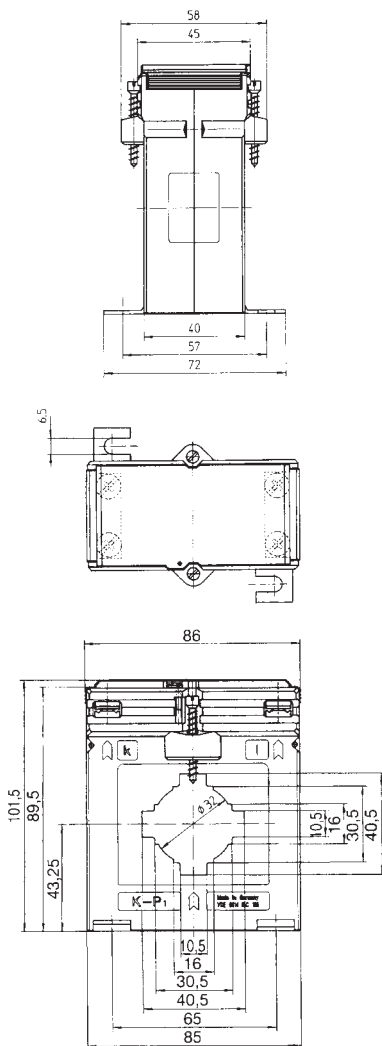
86 mm





# ASK 541.4

Plug-in current transformer



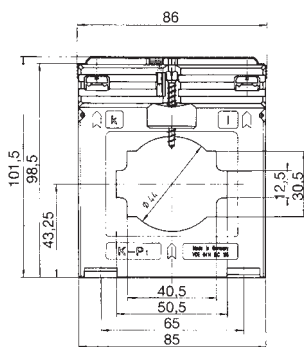
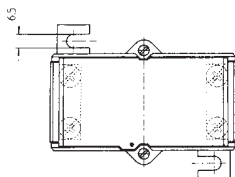
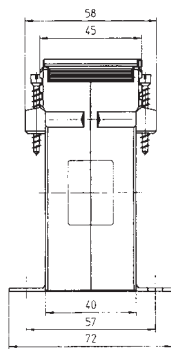
Primary conductor	40 x 10 mm 2 x 30 x 5 mm
Round conductor	Ø 32 mm
Transformer width	86 mm
Snap-on mounting	—
Sealed shutter	<b>Art.-no. 59042</b> see page 207
Protection plug-in current transformer	see page 142
Current transformer for tariff applications	see page 179

Secondary current		5A			1A	
Primary current A	Burden VA	Accuracy class			Accuracy class	
		1	0.5	0.2s	1	0.5
		Art.-no.	Art.-no.	Art.-no.	Art.-no.	Art.-no.
30	1				15248	
	1.5	15048				
40	1.5	15049			15249	
	2.5	15050			15250	
50	1.5	15051			15251	
	2.5	15052			15252	
60	1.5	15053	15013		15253	15213
	2.5	15054			15254	
75	1.5	15055	15014		15255	15214
	2.5	15056	15100		15256	15300
80	1.5	15057	15015		15257	15215
	2.5	15057	15016		15257	15216
100	1.5					
	2.5		15017			15217
	5	15059	15018		15259	15218
	10	15060			15260	
125	2.5		15019			15219
	5	15061	15020		15261	15220
	10	15062			15262	
150	2.5	15063	15021	V33-1604D	15263	15221
	5	15064	15022	V33-1604F	15264	15222
	10	15065	15343		15265	
200	2.5		15023	V33-1704D		15223
	5	15066	15024	V33-1704F	15266	15224
	10	15067	15101		15267	15301
	15	15068	15102		15268	15302
250	2.5		15025	V33-1804D		15225
	5	15069	15026	V33-1804F	15269	15226
	10	15070	15103	V33-1804H	15270	15303
	15	15071	15104		15271	15304
300	2.5		15027	V33-1904D		15227
	5	15072	15028	V33-1904F	15272	15228
	10	15073	15029	V33-1904H	15273	15229
	15	15074	15105		15274	15305
400	2.5		15030	V33-2004D		15230
	5	15075	15031	V33-2004F	15275	15231
	10	15076	15032	V33-2004H	15276	15232
	15	15077			15277	15339
500	2.5			V33-2104D		
	5		15033	V33-2104F		15233
	10	15078	15034	V33-2104H	15278	15234
	15	15079	15035	V33-2104J	15279	15235
	30	15080	15344		15280	
600	2.5			V33-2204D		
	5		15036	V33-2204F		15236
	10	15081	15037	V33-2204H	15281	15237
	15	15082	15038	V33-2204J	15282	15238
	30	15083	15039		15283	15239
750	2.5			V33-2304D		
	5			V33-2304F		
	10	15084	15040	V33-2304H	15284	15240
	15	15085	15041	V33-2304J	15285	15241
	30	15086	15042		15286	15242
800	10	15087	15043		15287	15243
	15	15088	15044		15288	15244
	30	15089	15106		15289	15306
1000	2.5			V33-2504D		
	5		15045	V33-2504F		15245
	10	15090	15046	V33-2504H	15290	15246
	15	15091	15047	V33-2504J	15291	15247
	30	15092			15292	



# ASK 51.4

Plug-in current transformer



Primary conductor	50 x 12 mm 2 x 40 x 10 mm
Round conductor	Ø 44 mm
Transformer width	86 mm
Snap-on mounting	—
Sealed shutter	<b>Art.-no. 59042</b> see page 207
Protection plug-in current transformer	see page 144
Current transformer for tariff applications	see page 180

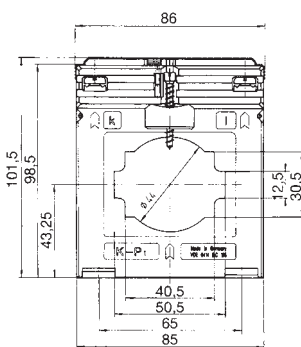
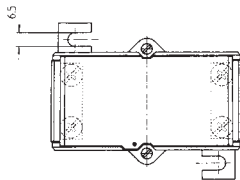
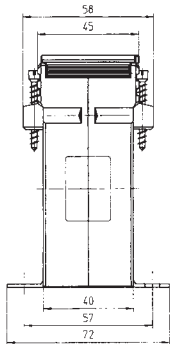
Secondary current		5A			1A	
Primary current A	Burden VA	Accuracy class			Accuracy class	
		1	0.5	0.2s	1	0.5
		Art.-no.	Art.-no.	Art.-no.	Art.-no.	Art.-no.
100	1.5	16043	16170		16243	
	2.5	16086	16171			
150	1.5	16044	16011		16244	16211
	2.5	16045	16010		16245	16210
200	1.5		16012	V34-1704C		16212
	2.5	16046	16013	V34-1704D	16246	16213
	5	16047	16152	V34-1704F	16247	16352
250	1.5		16014			16214
	2.5	16048	16015	V34-1804D	16248	16215
	5	16049	16153	V34-1804F	16249	16353
	10	16177			16390	
300	2.5	16050	16017	V34-1904D	16250	16217
	5	16051	16018	V34-1904F	16251	16218
	10	16052			16252	
400	2.5	16053	16019	V34-2004D	16253	16219
	5	16054	16020	V34-2004F	16254	16220
	10	16055	16021	V34-2004H	16255	16221
	15	16056	16201		16256	
	2.5	16057	16022	V34-2104D	16257	16222
500	5	16058	16023	V34-2104F	16258	16223
	10	16059	16024	V34-2104H	16259	16224
	15	16060	16202		16260	
600	2.5	16061	16025	V34-2204D	16261	16225
	5	16062	16026	V34-2204F	16262	16226
	10	16063	16027	V34-2204H	16263	16227
	15	16064	16154		16264	16354
750	2.5	16065	16028	V34-2304D	16265	16228
	5	16066	16029	V34-2304F	16266	16229
	10	16067	16030	V34-2304H	16267	16230
	15	16068	16203		16268	
800	5	16069	16031	V34-2404F	16269	16231
	10	16070	16032	V34-2404H	16270	16232
	15	16071	16033		16271	16233
	30	16072			16272	
1000	2.5			V34-2504D		
	5	16073	16034	V34-2504F	16273	16234
	10	16074	16035	V34-2504H	16274	16235
	15	16075	16036	V34-2504J	16275	16236
	30	16076			16276	
1200	5	16077	16037		16277	16237
	10	16078	16038		16278	16238
	15	16079	16039		16279	16239
	30	16080			16280	
1250	5	16081	16040		16281	16240
	10	16082	16041		16282	16241
	15	16083	16042		16283	16242
	30	16084			16284	

Secondary change-over transformers see page 68.

Continuation from page 67

# ASK 51.4 2u

Plug-in secondary change-over  
current transformer



Secondary current		5A	1A
Primary current A	Burden VA	Accuracy class	Accuracy class
		1	1
		Art.-no.	Art.-no.
400-200	5-2.5	16130	16330
	10-5	16131	16331
500-250	5-2.5	16132	16332
	10-5	16133	16333
600-300	5-2.5	16134	16334
	10-5	16135	16335
800-400	5-2.5	16136	16336
	10-5	16137	16337
	15-7.5	16138	16338
1000-500	5-2.5	16139	16339
	10-5	16140	16340
	15-7.5	16141	16341
1200-600	5-2.5	16142	16342
	10-5	16143	16343
	15-7.5	16144	16344
	30-15	16145	16345

# ASK 51.4 3u

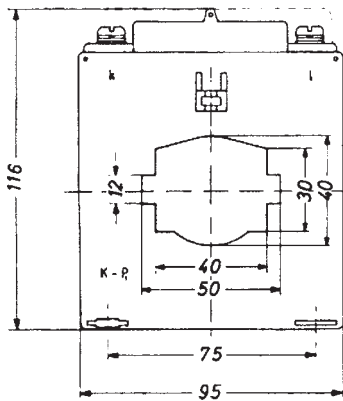
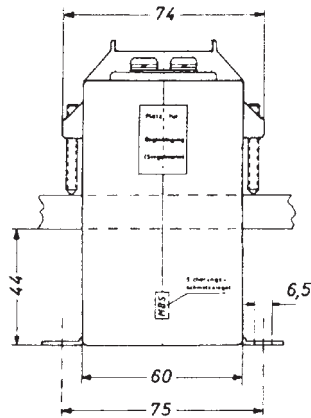
Secondary current		5A	1A
Primary current A	Burden VA	Accuracy class	Accuracy class
		1	1
		Art.-no.	Art.-no.
800-400-200	10-5-2.5	16162	16362
1000-500-250	10-5-2.5	16163	16363
	15-7.5-2.5	16164	16364
1200-600-300	10-5-2.5	16165	16365
	15-7.5-2.5	16166	16366
1200-1000-300	7.5-5-2.5	16174	16374
1000-600-400	10-5-2.5	16175	16375
1000-600-300	15-10-5	16176	16376
600-400-200	15-7.5-5	16178	16378
1000-800-600	15-10-5	16179	16379
1000-600-300	10-5-2.5	16180	16380

Primary conductor	50 x 12 mm 2 x 40 x 10 mm
Round conductor	Ø 44 mm
Transformer width	86 mm
Snap-on mounting	—
Sealed shutter	<b>Art.-no. 59042</b> see page 207
Protection plug-in current transformer	see page 144
Current transformer for tariff applications	see page 180



# ASK 51.6

Plug-in current transformer



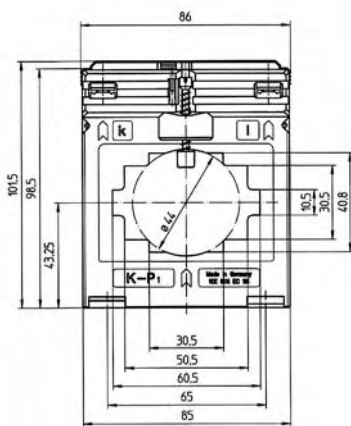
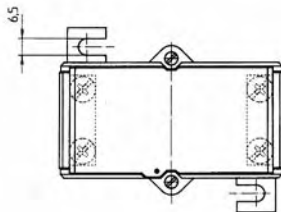
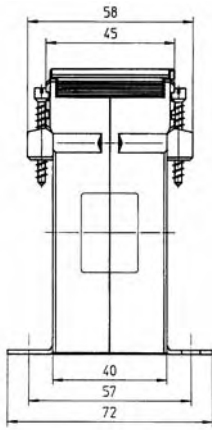
Primary conductor	50 x 12 mm 40 x 30 mm
Round conductor	Ø 40 mm
Transformer width	95 mm
Snap-on mounting	—
Sealed shutter	<b>Art.-no. 59044</b> see page 207
Protection plug-in current transformer	see page 146
Current transformer for tariff applications	see page 181

Secondary current		5A		1A	
Primary current A	Burden VA	Accuracy class		Accuracy class	
		1	0.5	1	0.5
		Art.-no.	Art.-no.	Art.-no.	Art.-no.
100	2.5	17058	17011	17258	17211
	5	17059	17012	17259	17212
150	2.5	17060	17013	17260	17213
	5	17061	17014	17261	17214
	10	17062	17015	17262	17215
200	2.5	17063	17016	17263	17216
	5	17064	17017	17264	17217
	10	17065	17018	17265	17218
250	2.5	17066	17019	17266	17219
	5	17067	17020	17267	17220
	10	17068	17021	17268	17221
	15	17069	17022	17269	17222
300	2.5		17023		17223
	5	17070	17024	17270	17224
	10	17071	17025	17271	17225
	15	17072	17026	17272	17226
400	30	17073		17273	
	2.5		17027		17227
	5	17074	17028	17274	17228
	10	17075	17029	17275	17229
	15	17076	17030	17276	17230
500	30	17077		17277	
	2.5		17031		17231
	5	17078	17032	17278	17232
	10	17079	17033	17279	17233
	15	17080	17034	17280	17234
600	30	17081		17281	
	2.5		17035		17235
	5	17082	17036	17282	17236
	10	17083	17037	17283	17237
	15	17084	17038	17284	17238
750	30	17085		17285	
	2.5		17039		17239
	5	17086	17040	17286	17240
	10	17087	17041	17287	17241
	15	17088	17042	17288	17242
800	30	17089		17289	
	10	17090	17044	17290	17244
	15	17091	17045	17291	17245
	30	17092		17292	
	45	17093		17293	
1000	5		17046		17246
	10	17094	17047	17294	17247
	15	17095	17048	17295	17248
	30	17096	17049	17296	17249
	45	17097		17297	
1200	5		17050		17250
	10	17098	17051	17298	17251
	15	17099	17052	17299	17252
	30	17100	17053	17300	17253
	45	17101		17301	
1250	5		17054		17254
	10	17102	17055	17302	17255
	15	17103	17056	17303	17256
	30	17104	17057	17304	17257
	45	17105		17305	



# ASK 561.4

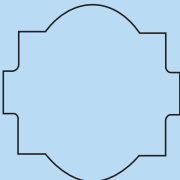
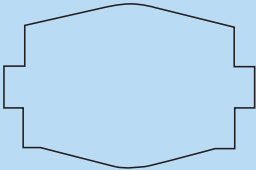
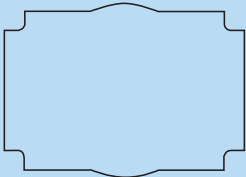

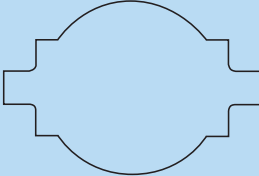

Plug-in current transformer



Secondary current		5A		1A	
Primary current A	Burden VA	Accuracy class		Accuracy class	
		1	0.5	1	0.5
		Art.-no.	Art.-no.	Art.-no.	Art.-no.
200	2.5	18036		18236	
250	2.5	18037		18237	
	5	18038		18238	
300	2.5	18039	18012	18239	18212
	5	18040	18013	18240	18213
400	2.5	18042	18014	18242	18214
	5	18043	18015	18243	18215
	10	18044		18244	
500	2.5		18016		18216
	5	18045	18017	18245	18217
	10	18046		18246	
	15	18047		18247	
600	2.5		18018		18218
	5	18048	18019	18248	18219
	10	18049	18020	18249	18220
	15	18050		18250	
750	2.5		18021		18221
	5	18051	18022	18251	18222
	10	18052	18023	18252	18223
	15	18053		18253	
800	5	18097	18024		18224
	10	18054	18025	18254	18225
	15	18055	18026	18255	18226
	30	18056		18256	
1000	5	18104	18027		18227
	10	18057	18028	18257	18228
	15	18058	18029	18258	18229
	30	18059		18259	
1200	5	18100	18030	18267	18230
	10	18060	18031	18260	18231
	15	18061	18032	18261	18232
	30	18062		18262	
1250	5	18102	18033		18233
	10	18063	18034	18263	18234
	15	18064	18035	18264	18235
	30	18065		18265	

Primary conductor	60 x 10 mm 30 x 40 mm 2 x 50 x 10 mm
Round conductor	Ø 44 mm
Transformer width	86 mm
Snap-on mounting	-
Sealed shutter	<b>Art.-no. 59042</b> see page 207

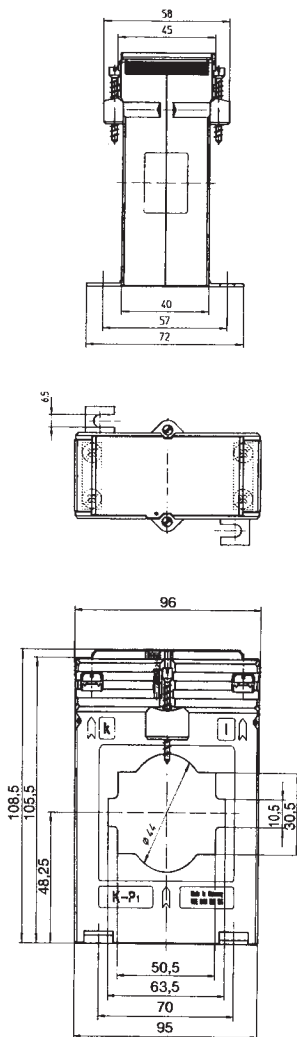
# Plug-in current transformers

<b>ASK 61.4</b>	Primary conductor		63 x 10 mm	
	<b>ASK 61.4 2u</b>		2 x 50 x 10 mm	
	<b>ASK 61.4 3u</b>		Transformer width Ø 44 mm 96 mm	
<b>ASK 61.6</b>	Primary conductor		60 x 10 mm	
	Round conductor		50 x 30 mm	
	Transformer width		Ø 40 mm 95 mm	
<b>ASK 63.4</b>	Primary conductor		60 x 30 mm	
	Round conductor		50 x 40 mm	
	Transformer width		Ø 44 mm 96 mm	
<b>ASK 63.6</b>	Primary conductor		60 x 30 mm	
	Round conductor		Ø 30 mm	
	Transformer width		88 mm	
<b>ASK 81.4</b>	Primary conductor		80 x 10 mm	
			<b>ASK 81.4 2u</b>	60 x 30 mm
			<b>ASK 81.4 3u</b>	2 x 60 x 10 mm Ø 55 mm 120 mm
<b>ASK 83.4</b>	Primary conductor		84 x 34 mm	
	Round conductor		Ø 34 mm	
	Transformer width		96 mm	



# ASK 61.4

## Plug-in current transformer



Primary conductor	63 x 10 mm 2 x 50 x 10 mm
Round conductor	Ø 44 mm
Transformer width	96 mm
Snap-on mounting	—
Sealed shutter	<b>Art.-no. 59042</b> see page 207
Protection plug-in current transformer	see page 150
Current transformer for tariff applications	see page 184

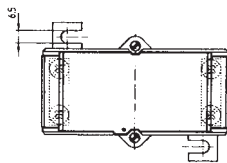
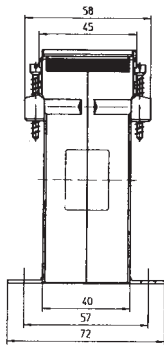
Secondary current		5A			1A	
Primary current A	Burden VA	Accuracy class			Accuracy class	
		1	0.5	0.2s	1	0.5
		Art.-no.	Art.-no.	Art.-no.	Art.-no.	Art.-no.
200	1.5	19047	19009		19247	19209
	2.5	19048	19010		19248	19210
250	1.5	19049	19011	V41-1804C	19249	19211
	2.5	19050	19012	V41-1804D	19250	19212
	5				19175	
300	1.5	19051	19013		19251	19213
	2.5	19052	19014	V41-1904D	19252	19214
	5	19053	19015	V41-1904F	19253	19215
400	1.5	19054	19016		19254	19216
	2.5	19055	19017	V41-2004D	19255	19217
	5	19056	19018	V41-2004F	19256	19218
	10	19057	19094	V41-2004H	19257	19294
500	1.5		19019			19219
	2.5	19058	19020	V41-2104D	19258	19220
	5	19059	19021	V41-2104F	19259	19221
	10	19060	19095	V41-2104H	19260	19295
	15	19061	19096		19261	19296
600	2.5	19062	19022	V41-2204D	19262	19222
	5	19063	19023	V41-2204F	19263	19223
	10	19064	19024	V41-2204H	19264	19224
	15	19065	19097	V41-2204J	19265	19297
750	2.5	19066	19025	V41-2304D	19266	19225
	5	19067	19026	V41-2304F	19267	19226
	10	19068	19027	V41-2304H	19268	19227
	15	19069	19098	V41-2304J	19269	19298
800	2.5	19070	19028		19270	19228
	5	19071	19029	V41-2404F	19271	19229
	10	19072	19030	V41-2404H	19272	19230
	15	19073	19031	V41-2404J	19273	19231
1000	2.5			V41-2504D		
	5	19074	19032	V41-2504F	19274	19232
	10	19075	19033	V41-2504H	19275	19233
	15	19076	19034	V41-2504J	19276	19234
	30	19077	19099		19277	19299
1200	2.5			V41-2604D		
	5	19078	19035	V41-2604F	19278	19235
	10	19079	19036	V41-2604H	19279	19236
	15	19080	19037	V41-2604J	19280	19237
1250	30	19081	19100		19281	19300
	5	19082	19038	V41-2704F	19282	19238
	10	19083	19039	V41-2704H	19283	19239
	15	19084	19040	V41-2704J	19284	19240
1500	30	19085	19101		19285	19301
	5	19086	19041	V41-2804F	19286	19241
	10	19087	19042	V41-2804H	19287	19242
	15	19088	19043	V41-2804J	19288	19243
	30	19089	19102		19289	19302
1600	5	19090	19044		19290	19244
	10	19091	19045		19291	19245
	15	19092	19046		19292	19246
	30	19093	19103		19293	19303

Secondary change-over transformers see page 73.

Continuation from page 72

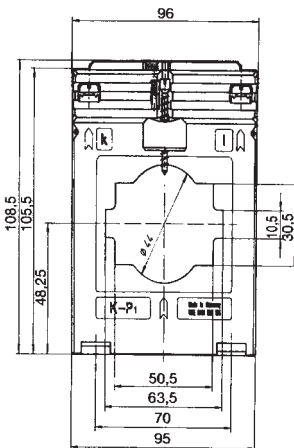
# ASK 61.4 2u

Plug-in secondary change-over  
current transformer



Secondary current		5A	1A	
Primary current A	Burden VA	Accuracy class	Accuracy class	
		1	1	
		Art.-no.	Art.-no.	
500-250	5-2.5	19141	19341	
	600-300	5-2.5	19142	19342
		10-5	19143	19343
800-400	5-2.5	19144	19344	
	10-5	19145	19345	
	15-7.5	19146	19346	
1000-500	5-2.5	19147	19347	
	10-5	19148	19348	
	15-7.5	19149	19349	
1200-600	5-2.5	19150	19350	
	10-5	19151	19351	
	15-7.5	19152	19352	
1500-750	5-2.5	19153	19353	
	10-5	19154	19354	
	15-7.5	19155	19355	
	30-15	19156	19356	
1600-800	5-2.5	19157	19357	
	10-7.5	19158	19358	
	15-7.5	19159	19359	
	30-15	19160	19360	

# ASK 61.4 3u



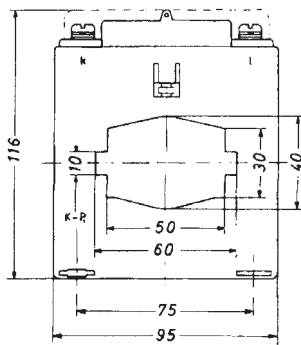
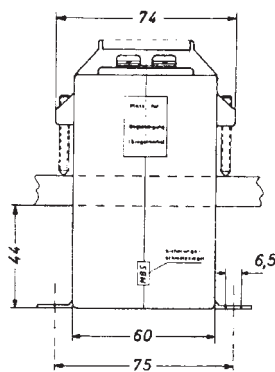
Secondary current		5A	1A
Primary current A	Burden VA	Accuracy class	Accuracy class
		1	1
		Art.-no.	Art.-no.
800-400-200	10-5-2.5	19182	19382
1000-500-250	10-5-2.5	19183	19383
	15-7.5-2.5	19184	19384
1000-600-300	10-5-2.5	19185	19385
	15-7.5-2.5	19186	19386
1200-600-300	10-5-2.5	19187	19387
	15-7.5-2.5	19188	19388
1500-750-400	10-5-2.5	19189	19389
	15-7.5-2.5	19190	19390
1600-800-400	10-5-2.5	19191	19391
	15-7.5-2.5	19192	19392
1000-600-400	10-5-2.5	19199	19399

Primary conductor	63 x 10 mm 2 x 50 x 10 mm
Round conductor	Ø 44 mm
Transformer width	96 mm
Snap-on mounting	—
Sealed shutter	<b>Art.-no. 59042</b> see page 207
Protection plug-in current transformers	see page 150



# ASK 61.6

Plug-in current transformer



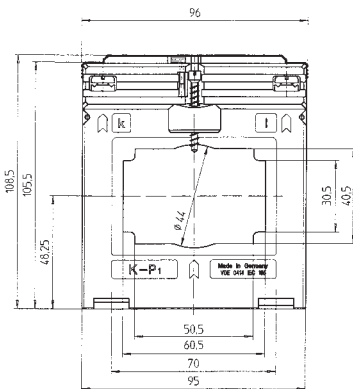
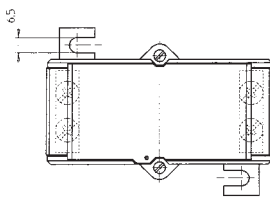
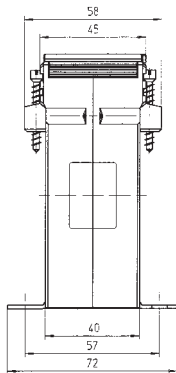
Primary conductor	60 x 10 mm 50 x 30 mm
Round conductor	Ø 40 mm
Transformer width	95 mm
Snap-on mounting	—
Sealed shutter	<b>Art.-no. 59044</b> see page 207
Current transformer for tariff applications	see page 185

Primary current A	Burden VA	Secondary current		5A		1A	
		Accuracy class		Accuracy class		Accuracy class	
		1	0.5	1	0.5	1	0.5
		Art.-no.	Art.-no.	Art.-no.	Art.-no.	Art.-no.	Art.-no.
100	1.5	20063	20011	20263	20211		
	2.5	20064		20264			
150	1.5	20065	20012	20265	20212		
	2.5	20066	20013	20266	20213		
200	2.5	20067	20014	20267	20214		
	5	20068	20015	20268	20215		
	10	20069		20269			
250	2.5	20116	20016	20321	20216		
	5	20070	20017	20270	20217		
	10	20071	20018	20271	20218		
	15	20072		20272			
300	2.5	20117	20019	20322	20219		
	5	20073	20020	20273	20220		
	10	20074	20021	20274	20221		
	15	20075	20022	20275	20222		
400	2.5	20118	20023	20323	20223		
	5	20076	20024	20276	20224		
	10	20077	20025	20277	20225		
	15	20078	20026	20278	20226		
	30	20079		20279			
500	2.5	20119	20027	20324	20227		
	5	20080	20028	20280	20228		
	10	20081	20029	20281	20229		
	15	20082	20030	20282	20230		
	30	20083		20283			
600	2.5	20120	20031	20325	20231		
	5	20084	20032	20284	20232		
	10	20085	20033	20285	20233		
	15	20086	20034	20286	20234		
	30	20087		20287			
750	2.5	20121	20035	20326	20235		
	5	20088	20036	20288	20236		
	10	20089	20037	20289	20237		
	15	20090	20038	20290	20238		
	30	20091		20291			
800	5	20092	20040	20292	20240		
	10	20093	20041	20293	20241		
	15	20094	20042	20294	20242		
	30	20095		20295			
1000	5	20122	20043	20327	20243		
	10	20096	20044	20296	20244		
	15	20097	20045	20297	20245		
	30	20098	20046	20298	20246		
	45	20099		20299			
1200	5	20123	20047	20328	20247		
	10	20100	20048	20300	20248		
	15	20101	20049	20301	20249		
	30	20102	20050	20302	20250		
	45	20103		20303			
1250	5	20124	20051	20329	20251		
	10	20104	20052	20304	20252		
	15	20105	20053	20305	20253		
	30	20106	20054	20306	20254		
	45	20107		20307			
1500	5	20125	20055	20330	20255		
	10	20108	20056	20308	20256		
	15	20109	20057	20309	20257		
	30	20110	20058	20310	20258		
	45	20111		20311			
1600	10	20112	20060	20312	20260		
	15	20113	20061	20313	20261		
	30	20114	20062	20314	20262		
	45	20115		20315			



# ASK 63.4

Plug-in current transformer



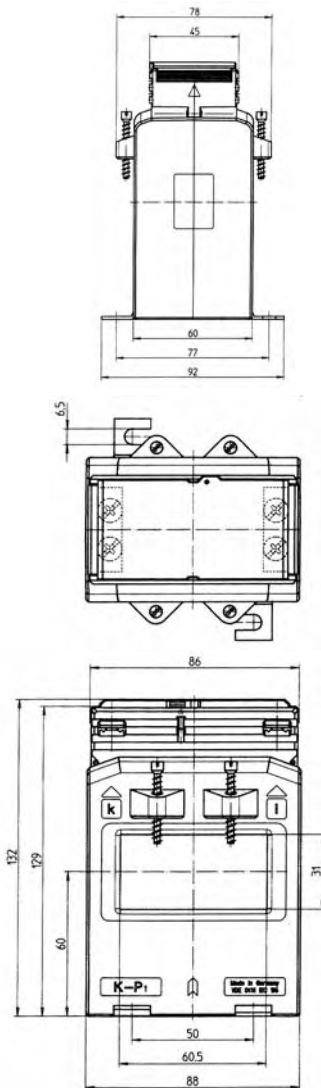
Secondary current		5A		1A	
Primary current A	Burden VA	Accuracy class		Accuracy class	
		1	0.5	1	0.5
		Art.-no.	Art.-no.	Art.-no.	Art.-no.
300	1.5	25041	25011	25241	25211
	2.5	25042	25012	25242	25212
400	2.5	25043	25013	25243	25213
	5	25044	25014	25244	25214
500	5	25045	25015	25245	25215
	10	25046		25246	
600	5	25047	25017	25247	25217
	10	25048	25018	25248	25218
	15	25049		25249	
750	5	25050	25020	25250	25220
	10	25051	25021	25251	25221
	15	25052	25022	25252	25222
800	5	25053	25023	25253	25223
	10	25054	25024	25254	25224
	15	25055	25025	25255	25225
1000	5	25056	25026	25256	25226
	10	25057	25027	25257	25227
	15	25058	25028	25258	25228
1200	5	25059	25029	25259	25229
	10	25060	25030	25260	25230
	15	25061	25031	25261	25231
1250	5	25062	25032	25262	25232
	10	25063	25033	25263	25233
	15	25064	25034	25264	25234
1500	5	25065	25035	25265	25235
	10	25066	25036	25266	25236
	15	25067	25037	25267	25237
1600	5	25068	25038	25268	25238
	10	25069	25039	25269	25239
	15	25070	25040	25270	25240
1800	5	25078	25071	25278	25271
	10	25079	25072	25279	25272
	15	25080	25073	25280	25273
2000	5	25081	25074	25281	25274
	10	25082	25076	25282	25276
	15	25083	25077	25283	25277

Primary conductor	60 x 30 mm 50 x 40 mm
Round conductor	Ø 44 mm
Transformer width	96 mm
Snap-on mounting	-
Sealed shutter	<b>Art.-no. 59042</b> see page 207



# ASK 63.6

Plug-in current transformer



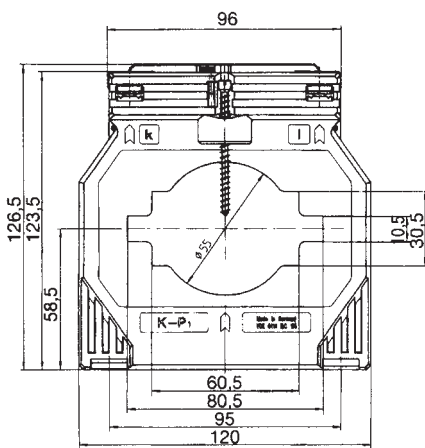
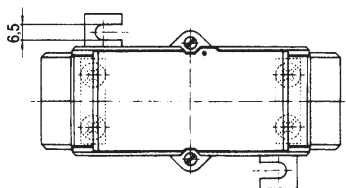
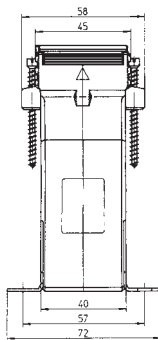
Primary conductor	60 x 30 mm
Round conductor	Ø 30 mm
Transformer width	88 mm
Snap-on mounting	—
Sealed shutter	<b>Art.-no. 59042</b> see page 207
Protection plug-in current transformer	see page 154
Current transformer for tariff applications	see page 186

Secondary current		5A		1A	
Primary current A	Burden VA	Accuracy class		Accuracy class	
		1	0.5	1	0.5
		Art.-no.	Art.-no.	Art.-no.	Art.-no.
200	1.5	85060		85260	
	2.5	85061		85261	
250	1.5	85062	85011	85262	85211
	2.5	85063	85012	85263	85212
	5				
300	1.5	85064	85013	85264	85213
	2.5	85065	85014	85265	85214
	5	85066	85015	85266	85215
	10	85067		85267	
400	2.5	85068	85017	85268	85217
	5	85069	85018	85269	85218
	10	85071			
500	2.5	85073	85021	85273	85221
	5	85074	85022	85274	85222
	10	85075		85275	
	15	85076		85276	
600	2.5	85077	85025	85277	85225
	5	85078	85026	85278	85226
	10	85079	85027	85279	85227
	15	85080		85280	
750	2.5	85081	85029	85281	85229
	5	85082	85030	85282	85230
	10	85083	85031	85283	85231
	15	85084		85284	
	30				
800	2.5	85085	85033	85285	85233
	5	85086	85034	85286	85234
	10	85087	85035	85287	85235
	15	85088	85036	85288	85236
1000	5	85089	85037	85289	85237
	10	85090	85038	85290	85238
	15	85091	85039	85291	85239
	30	85092		85292	
1200	5	85093	85041	85293	85241
	10	85094	85042	85294	85242
	15	85095	85043	85295	85243
	30	85096	85044	85296	85244
1250	5	85097	85045	85297	85245
	10	85098	85046	85298	85246
	15	85099	85047	85299	85247
	30	85100		85300	
1500	5	85101	85049	85301	85249
	10	85102	85050	85302	85250
	15	85103	85051	85303	85251
	30	85104		85304	
1600	5	85105	85053	85305	85253
	10	85106	85054	85306	85254
	15	85107	85055	85307	85255
	30	85108		85308	
2000	5	85109	85056	85309	85256
	10	85110	85057	85310	85257
	15	85111	85058	85311	85258
	30	85112	85059	85312	85259



# ASK 81.4

Plug-in current transformer



Primary conductor	80 x 10 mm 60 x 30 mm 2 x 60 x 10 mm
Round conductor	Ø 55 mm
Transformer width	120 mm
Snap-on mounting	—
Sealed shutter	<b>Art.-no. 59042</b> see page 207
Current transformer for tariff applications	see page 187

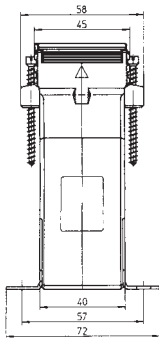
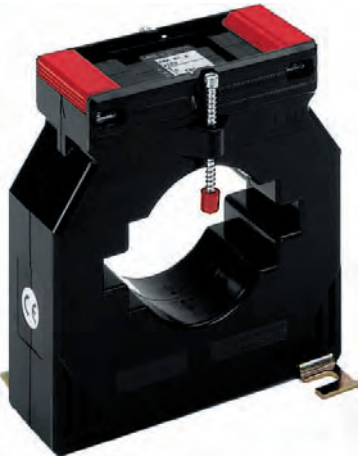
Secondary current		5A			1A	
Primary current A	Burden VA	Accuracy class			Accuracy class	
		1	0.5	0.2s	1	0.5
		Art.-no.	Art.-no.	Art.-no.	Art.-no.	Art.-no.
400	2.5	21038	21009	V47-2004D	21238	21209
	5	21039	21010	V47-2004F	21239	21210
	10		21197			
500	2.5	21040	21011	V47-2104D	21240	21211
	5	21041	21135	V47-2104F	21241	21335
	10	21042	21078		21242	21278
600	2.5	21043	21012	V47-2204D	21243	21212
	5	21044	21013	V47-2204F	21244	21213
	10	21045	21014	V47-2204H	21245	21214
750	2.5	21046	21015	V47-2304D	21246	21215
	5	21047	21016	V47-2304F	21247	21216
	10	21048	21017	V47-2304H	21248	21217
	15	21049	21079		21249	21279
800	2.5	21050	21018	V47-2404D	21250	21218
	5	21051	21019	V47-2404F	21251	21219
	10	21052	21020		21252	21220
	15	21053	21080		21253	21280
1000	2.5	21084		V47-2504D		
	5	21054	21021	V47-2504F	21254	21221
	10	21055	21022	V47-2504H	21255	21222
	15	21056	21023	V47-2504J	21256	21223
	30	21057			21257	
1200	5	21058	21024	V47-2604F	21258	21224
	10	21059	21025	V47-2604H	21259	21225
	15	21060	21026	V47-2604J	21260	21226
	30	21061			21261	
1250	5	21062	21027	V47-2704F	21262	21227
	10	21063	21028	V47-2704H	21263	21228
	15	21064	21029	V47-2704J	21264	21229
	30	21065			21265	
1500	5	21085	21030	V47-2804F		21230
	10	21066	21031	V47-2804H	21266	21231
	15	21067	21032	V47-2804J	21267	21232
	30	21068			21268	
	45	21069			21269	
1600	5	21086	21033			21233
	10	21070	21034		21270	21234
	15	21071	21035		21271	21235
	30	21072			21272	
	45	21073			21273	
2000	10	21074	21036		21274	21236
	15	21075	21037		21275	21237
	30	21076			21276	
	45	21077			21277	

Secondary change-over transformers see page 78.

Continuation from page 77

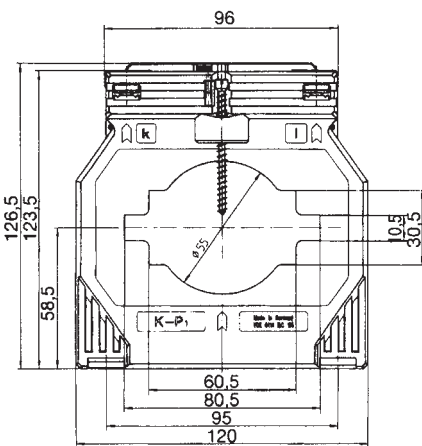
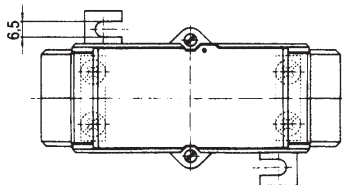
# ASK 81.4 2u

Plug-in secondary change-over current transformer



Secondary current		5A	1A
Primary current A	Burden VA	Accuracy class	Accuracy class
		1	1
		Art.-no.	Art.-no.
1000-500	10-5	21120	21320
	15-7.5	21121	21321
1200-600	10-5	21122	21322
	15-7.5	21123	21323
1500-750	10-5	21124	21324
	15-7.5	21125	21325
	30-15	21126	21326
1600-800	10-5	21127	21327
	15-7.5	21128	21328
	30-15	21129	21329
2000-1000	10-5	21130	21330
	15-7.5	21131	21331
	30-15	21132	21332

# ASK 81.4 3u



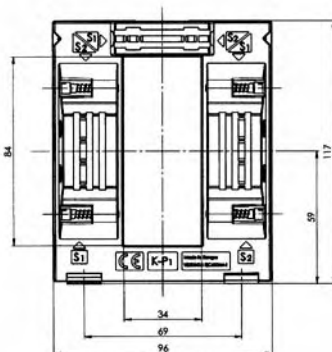
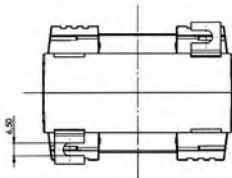
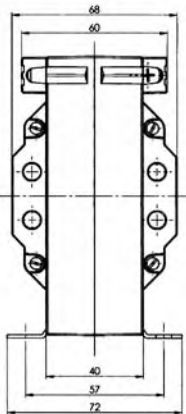
Secondary current		5A	1A
Primary current A	Burden VA	Accuracy class	Accuracy class
		1	1
		Art.-no.	Art.-no.
2000-1500-1000	30-15-10	21160	21360
2000-1000-500	30-10-5	21161	21361
1600-800-400	15-10-5	21162	21362
1500-1000-500	15-10-5	21163	21363
1200-800-600	15-10-5	21164	21364
1500-1000-750	15-10-5	21165	21365
1000-750-500	10-5-2.5	21166	21366

Primary conductor	80 x 10 mm 60 x 30 mm 2 x 60 x 10 mm
Round conductor	Ø 55 mm
Transformer width	120 mm
Snap-on mounting	—
Sealed shutter	<b>Art.-no. 59042</b> see page 207



# ASK 83.4

## Plug-in current transformer



Secondary current		5A		1A	
Primary current A	Burden VA	Accuracy class		Accuracy class	
		1	0.5	1	0.5
		Art.-no.	Art.-no.	Art.-no.	Art.-no.
300	1.5	100051-x	100011-x	100251-x	100211-x
	2.5	100052-x	100012-x	100252-x	100212-x
400	2.5	100053-x	100013-x	100253-x	100213-x
	5	100054-x	100014-x	100254-x	100214-x
500	2.5	100055-x	100015-x	100255-x	100215-x
	5	100056-x	100016-x	100256-x	100216-x
600	2.5	100057-x	100017-x	100257-x	100217-x
	5	100058-x	100018-x	100258-x	100218-x
	10	100059-x		100259-x	
750	2.5	100060-x	100019-x	100260-x	100219-x
	5	100061-x	100020-x	100261-x	100220-x
	10	100062-x	100021-x	100262-x	100221-x
	15	100063-x		100263-x	
800	2.5	100064-x	100022-x	100264-x	100222-x
	5	100065-x	100023-x	100265-x	100223-x
	10	100066-x	100024-x	100266-x	100224-x
	15	100067-x		100267-x	
1000	5	100068-x	100025-x	100268-x	100225-x
	10	100069-x	100026-x	100269-x	100226-x
	15	100070-x	100027-x	100270-x	100227-x
1200	5	100071-x	100028-x	100271-x	100228-x
	10	100072-x	100029-x	100272-x	100229-x
	15	100073-x	100030-x	100273-x	100230-x
1250	5	100074-x	100031-x	100274-x	100231-x
	10	100075-x	100032-x	100275-x	100232-x
	15	100076-x	100033-x	100276-x	100233-x
1500	5	100077-x	100034-x	100277-x	100234-x
	10	100078-x	100035-x	100278-x	100235-x
	15	100079-x	100036-x	100279-x	100236-x
1600	5	100080-x	100037-x	100280-x	100237-x
	10	100081-x	100038-x	100281-x	100238-x
	15	100082-x	100039-x	100282-x	100239-x
	30	100083-x		100283-x	
1800	10	100084-x	100040-x	100284-x	100240-x
	15	100085-x	100041-x	100285-x	100241-x
	30	100086-x		100286-x	
2000	10	100087-x	100042-x	100287-x	100242-x
	15	100088-x	100043-x	100288-x	100243-x
	30	100089-x		100289-x	
2500	10	100090-x	100044-x	100290-x	100244-x
	15	100091-x	100045-x	100291-x	100245-x
	30	100092-x		100292-x	

Connection options see page 81.

Primary conductor	84 x 34 mm
Round conductor	Ø 34 mm
Transformer width	96 mm

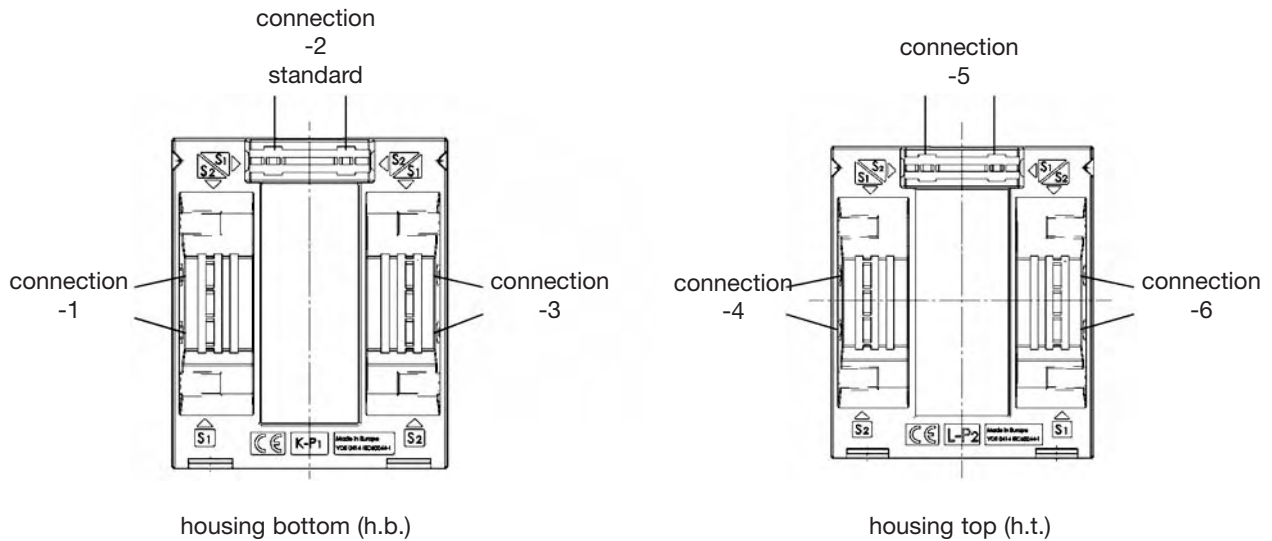


# ASK 83.4

## Plug-in current transformer

### Connection options

The plug-in current transformer ASK 83.4 is a multipurpose transformer which can be installed vertically or horizontally. There are 6 connection options to choose from.



### Order example

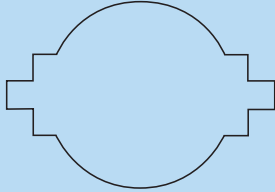
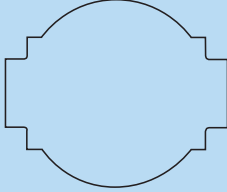
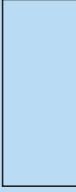
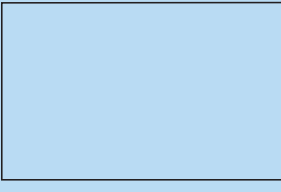

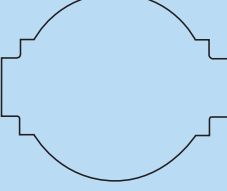
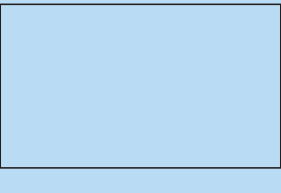

ASK 83.4 800/5 10/1

Connection option K-P<sub>1</sub> (h.b.) top

Art.-no. 100066-2



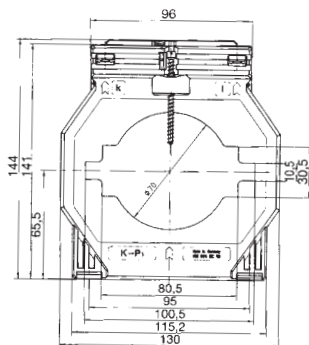
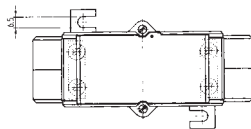
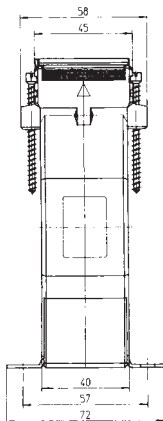
# Plug-in current transformers

<b>ASK 101.4</b> <b>ASK 101.4 2u</b>	Primary conductor		100 x 10 mm
	Round conductor Transformer width		2 x 80 x 10 mm Ø 70 mm 130 mm
<b>ASK 103.3</b>	Primary conductor		2 x 100 x 10 mm
	Round conductor Transformer width		3 x 80 x 10 mm Ø 85 mm 172 mm
<b>ASK 103.41</b> <b>ASK 103.41 2u</b>	Primary conductor		103 x 41 mm
	Round conductor Transformer width		Ø 40 mm 99 mm
<b>ASK 105.6</b>	Primary conductor		100 x 55 mm
	Round conductor Transformer width		Ø 55 mm 129 mm
<b>ASK 105.6 N</b>	Primary conductor		100 x 55 mm
	Round conductor Transformer width		Ø 55 mm 129 mm
<b>ASK 123.3</b>	Primary conductor		123 x 30 mm
	Round conductor Transformer width		3 x 100 x 10 mm Ø 100 mm 172 mm
<b>ASK 127.4</b>	Primary conductor		120 x 70 mm
	Round conductor Transformer width		Ø 70 mm 159 mm
<b>ASK 127.6</b>	Primary conductor		120 x 72 mm
	Round conductor Transformer width		Ø 72 mm 205 mm



# ASK 101.4

Plug-in current transformer



Secondary current		5A		1A	
Primary current A	Burden VA	Accuracy class		Accuracy class	
		1	0.5	1	0.5
		Art.-no.	Art.-no.	Art.-no.	Art.-no.
500	2.5		22009		22209
	5	22076	22010	22276	22210
	10	22077		22277	
600	2.5		22011		22211
	5	22038	22012	22238	22212
	10	22039	22239		
750	2.5		22013		22213
	5	22040	22014	22240	22214
	10	22041	22078	22241	22281
800	5	22042	22015	22242	22215
	10	22043	22016	22243	22216
	15	22044		22244	
1000	5	22045	22017	22245	22217
	10	22046	22018	22246	22218
	15	22047		22247	
	30	22115		22278	
1200	5	22048	22019	22248	22219
	10	22049	22020	22249	22220
	15	22050		22250	
	30	22051		22251	
1250	5	22052	22021	22252	22221
	10	22053	22022	22253	22222
	15	22054		22254	
	30	22055		22255	
1500	5	22056	22023	22256	22223
	10	22057	22024	22257	22224
	15	22058	22025	22258	22279
	30	22059		22259	
1600	5		22026		22226
	10	22060	22027	22260	22227
	15	22061	22028	22261	22228
	30	22062		22262	
	45	22063		22263	
1800	5		22029		22229
	10	22064	22030	22264	22230
	15	22065	22031	22265	22231
	30	22066		22266	
	45	22067		22267	
2000	5		22032		22232
	10	22068	22033	22268	22233
	15	22069	22034	22269	22234
	30	22070	22118	22270	22280
	45	22071		22271	
2500	5		22035		22235
	10	22072	22036	22272	22236
	15	22073	22037	22273	22237
	30	22074	22119	22274	22337
	45	22075		22275	

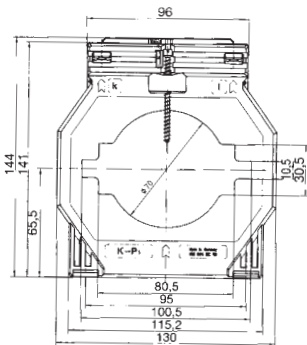
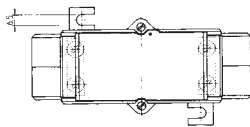
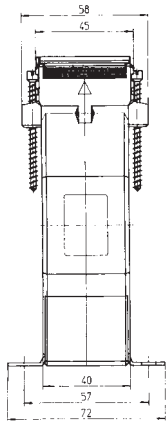
Primary conductor	100 x 10 mm 2 x 80 x 10 mm
Round conductor	Ø 70 mm
Transformer width	130 mm
Snap-on mounting	—
Sealed shutter	<b>Art.-no. 59042</b> see page 207

Secondary change-over transformers see page 85.

Continuation from page 84

# ASK 101.4 2u

Plug-in secondary change-over current transformer



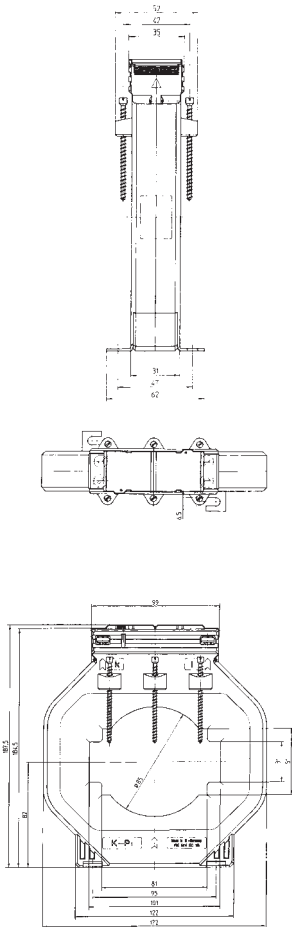
Secondary current		5A	1A
Primary current A	Burden VA	Accuracy class	Accuracy class
		1	1
		Art.-no.	Art.-no.
1200-600	10-5	22120	22320
	15-7.5	22121	22321
1500-750	10-5	22122	22322
	15-7.5	22123	22323
1600-800	10-5	22124	22324
	15-7.5	22125	22325
	30-15	22126	22326
	10-5	22127	22327
2000-1000	15-7.5	22128	22328
	30-15	22129	22329
	10-5	22130	22330
2500-1250	15-7.5	22131	22331
	30-15	22132	22332

Primary conductor	100 x 10 mm 2 x 80 x 10 mm
Round conductor	Ø 70 mm
Transformer width	130 mm
Snap-on mounting	—
Sealed shutter	<b>Art.-no. 59042</b> see page 207



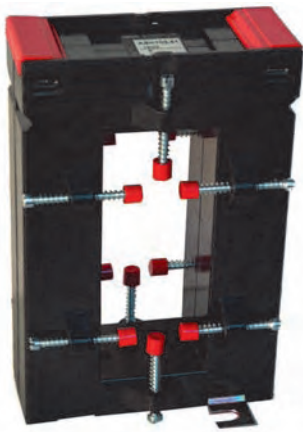
# ASK 103.3

Plug-in current transformer



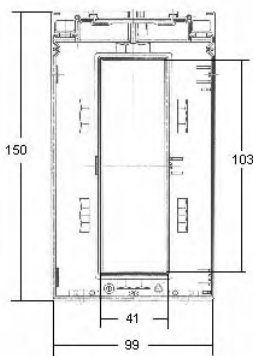
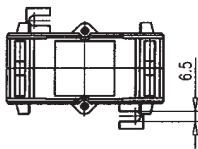
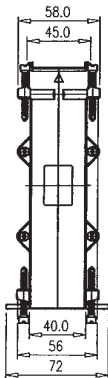
Secondary current		5A		1A	
Primary current A	Burden VA	Accuracy class		Accuracy class	
		1	0.5	1	0.5
		Art.-no.	Art.-no.	Art.-no.	Art.-no.
750	2.5		23011		23211
	5	23036		23236	
	10	23037		23237	
800	2.5		23012		23212
	5	23038	23013	23238	23213
	10	23039		23239	
	15	23040		23240	
1000	5	23041	23014	23241	23214
	10	23042	23015	23242	23215
	15	23043	23016	23243	23216
1200	5	23044	23017	23244	23217
	10	23045	23018	23245	23218
	15	23046	23019	23246	23219
	30	23047		23247	
1250	5	23048	23020	23248	23220
	10	23049	23021	23249	23221
	15	23050	23022	23250	23222
	30	23051		23251	
1500	10	23052	23023	23252	23223
	15	23053	23024	23253	23224
	30	23054		23254	
	45	23055		23255	
1600	10	23056	23025	23256	23225
	15	23057	23026	23257	23226
	30	23058		23258	
	45	23059		23259	
2000	10	23060	23027	23260	23227
	15	23061	23028	23261	23228
	30	23062	23029	23262	23229
	45	23063		23263	
2500	10	23064	23030	23264	23230
	15	23065	23031	23265	23231
	30	23066	23032	23266	23232
	45	23067		23267	
3000	10	23068	23033	23268	23233
	15	23069	23034	23269	23234
	30	23070	23035	23270	23235
	45	23071		23271	

Primary conductor	2 x 100 x 10 mm 3 x 80 x 10 mm
Round conductor	Ø 85 mm
Transformer width	172 mm
Snap-on mounting	—
Sealed shutter 2 pieces	<b>Art.-no. 59040</b> see page 207



# ASK 103.41

Plug-in current transformer



Secondary current		5A		1A	
Primary current A	Burden VA	Accuracy class		Accuracy class	
		1	0.5	1	0.5
		Art.-no.	Art.-no.	Art.-no.	Art.-no.
400	2.5	97051	97021	97251	97221
	5	97052		97252	
500	2.5	97053	97023	97253	97223
	5	97054		97254	
600	2.5	97055	97025	97255	97225
	5	97056		97256	
750	2.5	97057	97027	97257	97227
	5	97058		97258	
800	5	97059	97029	97259	97229
	10	97060		97260	
1000	10	97061	97031	97261	97231
	15	97062		97262	
1200	10	97063	97033	97263	97233
	15	97064		97264	
1250	10	97065	97035	97265	97235
	15	97066		97266	
1500	15	97067	97037	97267	97237
	30	97068		97268	
	30	97069	97039	97269	97239
2000	15	97069	97039	97269	97239
	30	97070		97270	

# ASK 103.41 2u

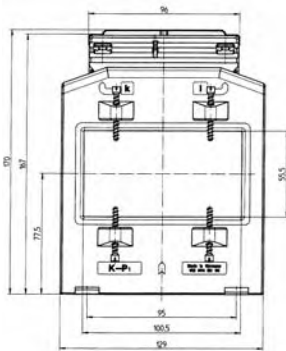
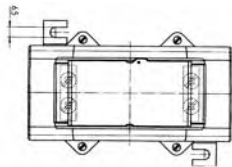
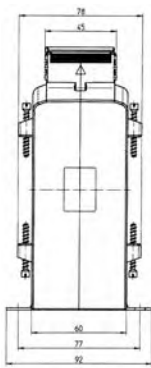
Plug-in secondary change-over current transformer

Secondary current		5A		1A	
Primary current A	Burden VA	Accuracy class		Accuracy class	
		1	0.5	1	0.5
		Art.-no.	Art.-no.	Art.-no.	Art.-no.
1000-500	5-2.5	97081	97071	97281	97271
	5-2.5	97082	97072	97282	97272
1500-750	10-5	97083	97073	97283	97273
	15-7.5	97084		97284	
2000-1000	15-7.5	97085	97075	97285	97275
	30-15	97086		97286	

Primary conductor	103 x 41 mm
Round conductor	Ø 40 mm
Transformer width	99 mm
Snap-on mounting	—
Sealed shutter	—

# ASK 105.6

## Plug-in current transformer

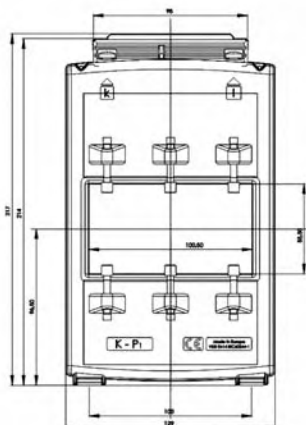
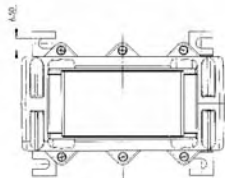
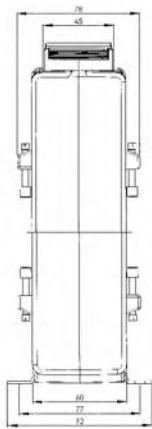


Primary conductor	100 x 55 mm
Round conductor	Ø 55 mm
Transformer width	129 mm
Snap-on mounting	—
Sealed shutter	<b>Art.-no. 59042</b> see page 207
Protection plug-in current transformer	see page 155
Current transformer for tariff applications	see page 190

Secondary current		5A			1A	
Primary current A	Burden VA	Accuracy class			Accuracy class	
		1	0.5	0.2s	1	0.5
		Art.-no.	Art.-no.	Art.-no.	Art.-no.	Art.-no.
600	2.5		86083	V55-2204D		86283
	5	86092	86084		86292	86284
	10	86093			86293	
750	2.5		86086	V55-2304D		86286
	5	86095	86087	V55-2304F	86295	86287
	10	86096	86157		86296	
800	5	86097	86089	V55-2404F	86297	86289
	10	86098	86090	V55-2404H	86298	86290
1000	2.5		86158	V55-2504D		
	5	86051	86011	V55-2504F	86251	86211
	10	86052	86159	V55-2504H	86252	
	15		86160		86299	
1200	5	86053	86013	V55-2604F	86253	86213
	10	86054	86014	V55-2604H	86254	86214
	15	86055	86015		86255	86215
1250	5	86056	86016	V55-2704F	86256	86216
	10	86057	86017	V55-2704H	86257	86217
	15	86058	86018	V55-2704J	86258	86218
	30		86162			
1500	5	86059	86019	V55-2804F	86259	86219
	10	86060	86020	V55-2804H	86260	86220
	15	86061	86021	V55-2804J	86261	86221
	30	86062	86163		86262	
1600	5	86110	86164	V55-2904F		
	10	86142	86165	V55-2904H	86331	86338
	15	86101	86149	V55-2904J	86330	86339
	30	86138	86166		86337	86340
1800	5	86063	86023		86263	86223
	10	86064	86024		86264	86224
	15	86065	86025		86265	86225
	30	86066			86266	
2000	5		86167	V55-3004F		
	10	86067	86027	V55-3004H	86267	86227
	15	86068	86028	V55-3004J	86268	86228
	30	86069	86029		86269	86229
	45	86070			86270	
2400	5		86168	V55-3104F		
	10		86169	V55-3104H		
	15		86170	V55-3104J		
	30		86171			
2500	5		86172	V55-3204F		
	10	86071	86031	V55-3204H	86271	86231
	15	86072	86032	V55-3204J	86272	86232
	30	86073	86033		86273	86233
	45	86074			86274	
3000	5		86173	V55-3304F		
	10	86075	86035	V55-3304H	86275	86235
	15	86076	86036	V55-3304J	86276	86236
	30	86077	86037		86277	86237
45	86078			86278		

# ASK 105.6 N

Plug-in current transformer

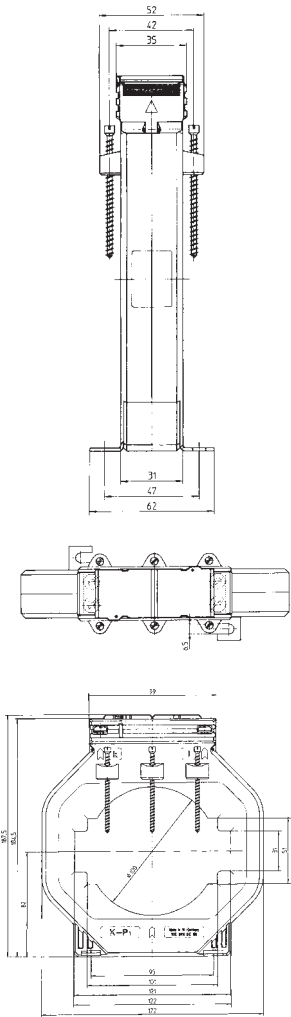


Secondary current		5A		1A	
Primary current A	Burden VA	Accuracy class		Accuracy class	
		1	0.5	1	0.5
		Art.-no.	Art.-no.	Art.-no.	Art.-no.
2500	10	86451	86481	86411	86431
	15	86452	86482	86412	86432
	30	86453	86483	86413	86433
	45	86454		86414	
3000	10	86455	86484	86415	86434
	15	86456	86485	86416	86435
	30	86457	86486	86417	86436
	45	86458		86418	
4000	10	86459	86487	86419	86437
	15	86460	86488	86420	86438
	30	86461	86489	86421	86439
	45	86462		86422	
5000	10	86463	86490	86423	86440
	15	86464	86491	86424	86441
	30	86465	86492	86425	86442
	45	86466		86426	

Primary conductor	100 x 55 mm
Round conductor	Ø 55 mm
Transformer width	129 mm
Snap-on mounting	—
Sealed shutter	<b>Art.-no. 59042</b> see page 207

# ASK 123.3

## Plug-in current transformer



Secondary current		5A			1A	
Primary current A	Burden VA	Accuracy class			Accuracy class	
		1	0.5	0.2s	1	0.5
		Art.-no.	Art.-no.	Art.-no.	Art.-no.	Art.-no.
750	2.5		24127			
	5		24128			
	10		24129			
1000	2.5		24010	V56-2504D		
	5	24037	24011	V56-2504F	24237	24211
	10	24038	24126		24238	24125
1200	5	24039	24012	V56-2604F	24239	24212
	10	24040	24013		24240	24213
	15	24041	24014		24241	24214
1250	5	24042	24015	V56-2704F	24242	24215
	10	24043	24016	V56-2704H	24243	24216
	15	24044	24017		24244	24217
1500	5	24045	24018	V56-2804F	24245	24218
	10	24046	24019	V56-2804H	24246	24219
	15	24047	24020		24247	24220
	30	24048	24130		24248	
1600	5	24112		V56-2904F		
	10	24107		V56-2904H		
	15	24113		V56-2904J		
	30	24108	24131			
1800	5	24049	24021		24249	24221
	10	24050	24022		24250	24222
	15	24051	24023		24251	24223
	30	24052			24252	
2000	5		24024	V56-3004F		24224
	10	24053	24025	V56-3004H	24253	24225
	15	24054	24026	V56-3004J	24254	24226
	30	24055	24027		24255	24227
2500	45	24056			24256	
	5		24136	V56-3204F		
	10	24057	24028	V56-3204H	24257	24228
	15	24058	24029	V56-3204J	24258	24229
3000	30	24059	24030		24259	24230
	45	24060			24260	
	5		24137	V56-3304F		
	10	24061	24031	V56-3304H	24261	24231
4000	15	24062	24032	V56-3304J	24262	24232
	30	24063	24033		24263	24233
	45	24064			24264	
	10	24065	24034		24265	24234
4000	15	24066	24035		24266	24235
	30	24067	24036		24267	24236
	45	24068			24268	

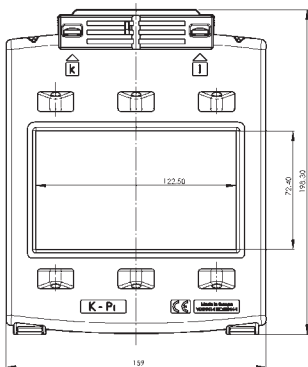
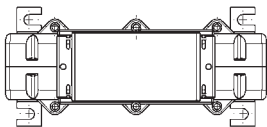
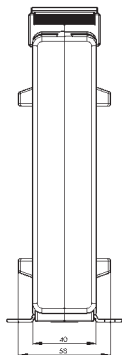
Primary conductor	123 x 30 mm 3 x 100 x 10 mm
Round conductor	Ø 100 mm
Transformer width	172 mm
Snap-on mounting	—
Sealed shutter 2 pieces	<b>Art.-no. 59040</b> see page 207
Tariff current transformer tariff applications	see page 191



# ASK 127.4

Plug-in current transformer

Secondary current		5A		1A	
Primary current A	Burden VA	Accuracy class		Accuracy class	
		1	0.5	1	0.5
		Art.-no.	Art.-no.	Art.-no.	Art.-no.
1000	5	87540	87510	87640	87610
	10	87541	87511	87641	87611
1200	5	87542	87512	87642	87612
	10	87543	87513	87643	87613
	15	87544	87514	87644	87614
1250	10	87545	87515	87645	87615
	15	87546	87516	87646	87616
	30	87547	87517	87647	87617
1500	10	87548	87518	87648	87618
	15	87549	87519	87649	87619
	30	87550	87520	87650	87620
1600	10	87551	87521	87651	87621
	15	87552	87522	87652	87622
	30	87553	87523	87653	87623
1800	10	87554	87524	87654	87624
	15	87555	87525	87655	87625
	30	87556	87526	87656	87626
2000	10	87557	87527	87657	87627
	15	87558	87528	87658	87628
	30	87559	87529	87659	87629
	45	87560	87530	87660	87630
2500	10	87561	87531	87661	87631
	15	87562	87532	87662	87632
	30	87563	87533	87663	87633
	45	87564	87534	87664	87634

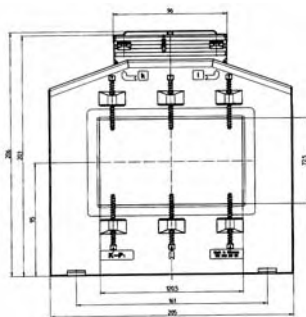
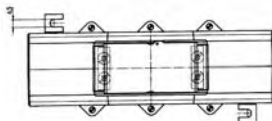
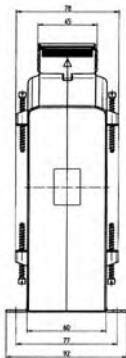


Primary conductor	120 x 70 mm
Round conductor	Ø 70 mm
Transformer width	159 mm
Snap-on mounting	—
Sealed shutter	<b>Art.-no. 59042</b> see page 207



# ASK 127.6





Plug-in current transformer



Secondary current		5A		1A	
Primary current A	Burden VA	Accuracy class		Accuracy class	
		1	0.5	1	0.5
		Art.-no.	Art.-no.	Art.-no.	Art.-no.
1000	5	87055	87011	87255	87211
	10	87056		87256	
1200	5	87057	87013	87257	87213
	10	87058	87014	87258	87214
	15	87059		87259	
1250	5	87060	87016	87260	87216
	10	87061	87017	87261	87217
	15	87062	87018	87262	87218
	30	87063	87019	87263	87219
1500	5	87064	87020	87264	87220
	10	87065	87021	87265	87221
	15	87066	87022	87266	87222
	30	87067	87023	87267	87223
1800	5	87068	87024	87268	87224
	10	87069	87025	87269	87225
	15	87070	87026	87270	87226
	30	87071	87027	87271	87227
2000	10	87072	87028	87272	87228
	15	87073	87029	87273	87229
	30	87074	87030	87274	87230
	45	87075		87275	
2500	10	87076	87032	87276	87232
	15	87077	87033	87277	87233
	30	87078	87034	87278	87234
	45	87079		87279	
3000	10	87081	87036	87281	87236
	15	87082	87037	87282	87237
	30	87083	87038	87283	87238
	45	87084		87284	
4000	10	87085	87040	87285	87240
	15	87086	87041	87286	87241
	30	87087	87042	87287	87242
	45	87088		87288	
5000	10	87089	87044	87289	87244
	15	87090	87045	87290	87245
	30	87091	87046	87291	87246
	45	87092		87292	
6000	10	87093	87048	87293	87248
	15	87094	87049	87294	87249
	30	87095	87050	87295	87250
	45	87096		87296	

Primary conductor	120 x 70 mm
Round conductor	Ø 70 mm
Transformer width	159 mm
Snap-on mounting	—
Sealed shutter	<b>Art.-no. 59042</b> see page 207

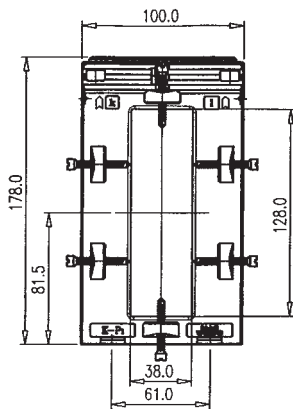
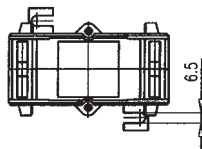
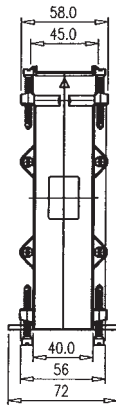
# Plug-in current transformers

<b>ASK 128.4</b>	Primary conductor Round conductor Transformer width		128 x 38 mm Ø 38 mm 100 mm
<b>ASK 129.10</b>	Primary conductor Round conductor Transformer width		120 x 90 mm Ø 90 mm 250 mm
<b>ASK 130.3</b>	Primary conductor Round conductor Transformer width		130 x 25 mm Ø 25 mm 180 mm
<b>ASK 130.5</b>	Primary conductor Round conductor Transformer width		130 x 30 mm Ø 30 mm 180 mm



# ASK 128.4

Plug-in current transformer



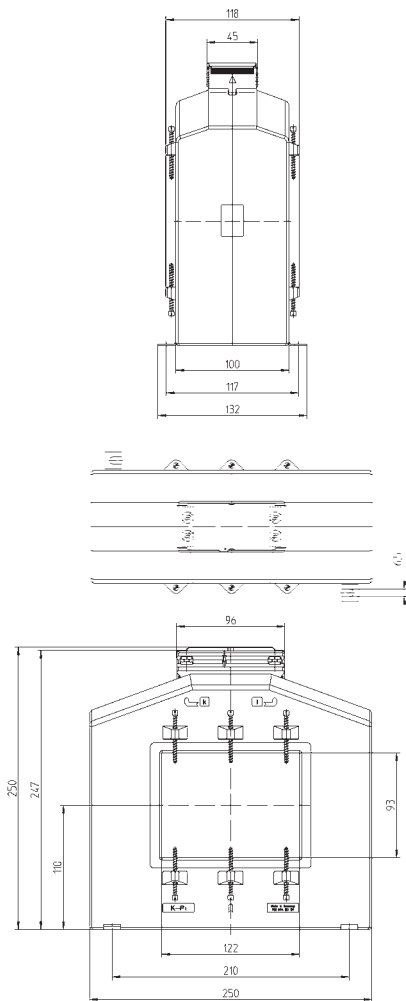
Secondary current		5A		1A	
Primary current A	Burden VA	Accuracy class		Accuracy class	
		1	0.5	1	0.5
		Art.-no.	Art.-no.	Art.-no.	Art.-no.
400	2.5	94041	94011	94241	94211
	5	94042		94242	
500	2.5	94043	94013	94243	94213
	5	94044		94244	
600	2.5	94045	94015	94245	94215
	5	94046		94246	
750	2.5	94047	94017	94247	94217
	5	94048		94248	
800	5	94049	94019	94249	94219
	10	94050		94250	
1000	10	94051	94021	94251	94221
	15	94052		94252	
1200	10	94053	94023	94253	94223
	15	94054		94254	
1250	10	94055	94025	94255	94225
	15	94056		94256	
1500	15	94057	94027	94257	94227
	30	94058		94258	
	30	94059	94029	94259	94229
2000	15	94059	94029	94259	94229
	30	94060		94260	
	30	94061	94031	94261	94231
2500	15	94061	94031	94261	94231
	30	94062		94262	

Primary conductor	128 x 38 mm
Round conductor	Ø 38 mm
Transformer width	100 mm
Snap-on mounting	—
Sealed shutter	<b>Art.-no. 59042</b> see page 207



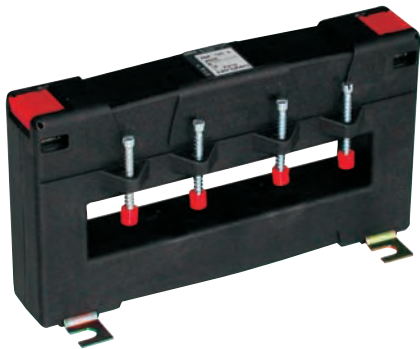
# ASK 129.10

Plug-in current transformer



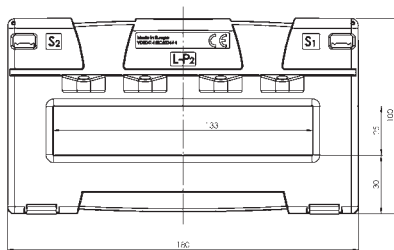
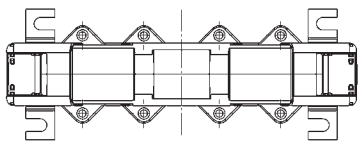
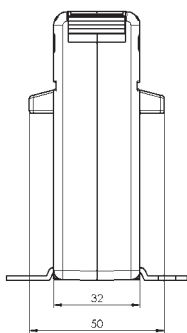
Secondary current		5A		1A	
Primary current A	Burden VA	Accuracy class		Accuracy class	
		1	0.5	1	0.5
		Art.-no.	Art.-no.	Art.-no.	Art.-no.
1000	5	88070	88011	88270	88211
	10	88071		88271	
	15	88072		88272	
1200	5	88073	88014	88273	88214
	10	88074	88015	88274	88215
	15	88075		88275	
1250	5	88076	88017	88276	88217
	10	88077	88018	88277	88218
	15	88078		88278	
1500	10	88079	88020	88279	88220
	15	88080	88021	88280	88221
	30	88081	88022	88281	88222
1600	10	88082	88023	88282	88223
	15	88083	88024	88283	88224
	30	88084	88025	88284	88225
1800	10	88085	88026	88285	88226
	15	88086	88027	88286	88227
	30	88087	88028	88287	88228
2000	10	88088	88029	88288	88229
	15	88089	88030	88289	88230
	30	88090	88031	88290	88231
2500	15	88091	88032	88291	88232
	30	88092	88033	88292	88233
	45	88093	88034	88293	88234
3000	15	88094	88035	88294	88235
	30	88095	88036	88295	88236
	45	88096	88037	88296	88237
4000	15	88097	88038	88297	88238
	30	88098	88039	88298	88239
	45	88099	88040	88299	88240
5000	15	88100	88041	88300	88241
	30	88101	88042	88301	88242
	45	88102	88043	88302	88243
6000	15	88103	88044	88303	88244
	30	88104	88045	88304	88245
	45	88105	88046	88305	88246
7500	15	88106	88047	88306	88247
	30	88107	88048	88307	88248
	45	88108	88049	88308	88249

Primary conductor	120 x 90 mm
Round conductor	Ø 90 mm
Transformer width	250 mm
Snap-on mounting	—
Sealed shutter	<b>Art.-no. 59042</b> see page 207



# ASK 130.3

Plug-in current transformer



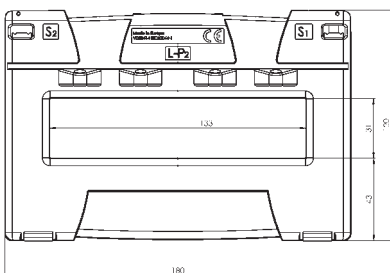
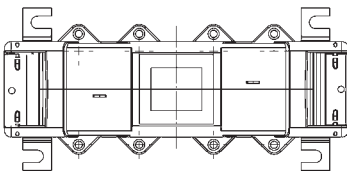
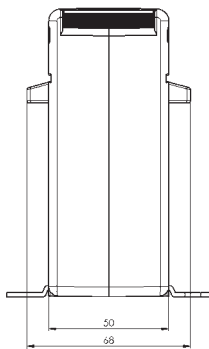
Secondary current		5A			1A	
Primary current A	Burden VA	Accuracy class			Accuracy class	
		1	0.5	0.2s	1	0.5
		Art.-no.	Art.-no.	Art.-no.	Art.-no.	Art.-no.
300	2.5	I50-1900D	I50-1901D		I50-1910D	I50-1911D
	5	I50-1900F	I50-1901F		I50-1910F	I50-1911F
400	2.5	I50-2000D	I50-2001D		I50-2010D	I50-2011D
	5	I50-2000F	I50-2001F		I50-2010F	I50-2011F
	10	I50-2000H	I50-2001H		I50-2010H	I50-2011H
500	2.5	I50-2100D	I50-2101D		I50-2110D	I50-2111D
	5	I50-2100F	I50-2101F		I50-2110F	I50-2111F
	10	I50-2100H	I50-2101H		I50-2110H	I50-2111H
600	2.5	I50-2200D	I50-2201D		I50-2210D	I50-2211D
	5	I50-2200F	I50-2201F		I50-2210F	I50-2211F
	10	I50-2200H	I50-2201H		I50-2210H	I50-2211H
	15	I50-2200J			I50-2210J	
750	2.5	I50-2300D	I50-2301D	V50-2304D	I50-2310D	I50-2311D
	5	I50-2300F	I50-2301F		I50-2310F	I50-2311F
	10	I50-2300H	I50-2301H		I50-2310H	I50-2311H
	15	I50-2300J	I50-2301J		I50-2310J	I50-2311J
1000	5	I50-2500F	I50-2501F	V50-2504F	I50-2510F	I50-2511F
	10	I50-2500H	I50-2501H	V50-2504H	I50-2510H	I50-2511H
	15	I50-2500J	I50-2501J		I50-2510J	I50-2511J
	30	I50-2500L			I50-2510L	
1200	5	I50-2600F	I50-2601F	V50-2604F	I50-2610F	I50-2611F
	10	I50-2600H	I50-2601H	V50-2604H	I50-2610H	I50-2611H
	15	I50-2600J	I50-2601J		I50-2610J	I50-2611J
	30	I50-2600L			I50-2610L	
1250	5	I50-2700F	I50-2701F	V50-2704F	I50-2710F	I50-2711F
	10	I50-2700H	I50-2701H	V50-2704H	I50-2710H	I50-2711H
	15	I50-2700J	I50-2701J	V50-2704J	I50-2710J	I50-2711J
	30	I50-2700L			I50-2710L	
1500	5	I50-2800F	I50-2801F	V50-2804F	I50-2810F	I50-2811F
	10	I50-2800H	I50-2801H	V50-2804H	I50-2810H	I50-2811H
	15	I50-2800J	I50-2801J	V50-2804J	I50-2810J	I50-2811J
	30	I50-2800L	I50-2801L		I50-2810L	I50-2811L
1600	5	I50-2900F	I50-2901F	V50-2904F	I50-2910F	I50-2911F
	10	I50-2900H	I50-2901H	V50-2904H	I50-2910H	I50-2911H
	15	I50-2900J	I50-2901J	V50-2904J	I50-2910J	I50-2911J
	30	I50-2900L	I50-2901L		I50-2910L	I50-2911L

Primary conductor	130 x 25 mm
Round conductor	Ø 25 mm
Transformer width	180 mm
Snap-on mounting	—
Sealed shutter	—
Current transformer for tariff applications	see page 192



# ASK 130.5

Plug-in current transformer



Primary conductor	130 x 30 mm
Round conductor	Ø 30 mm
Transformer width	180 mm
Snap-on mounting	—
Sealed shutter	—
Current transformer for tariff applications	see page 193

Secondary current		5A			1A	
Primary current A	Burden VA	Accuracy class			Accuracy class	
		1	0.5	0.2s	1	0.5
		Art.-no.	Art.-no.	Art.-no.	Art.-no.	Art.-no.
300	2.5	I51-1900D	I51-1901D		I51-1910D	I51-1911D
	5	I51-1900F	I51-1901F		I51-1910F	I51-1911F
	10	I51-1900H	I51-1901H		I51-1910H	I51-1911H
400	2.5	I51-2000D	I51-2001D		I51-2010D	I51-2011D
	5	I51-2000F	I51-2001F		I51-2010F	I51-2011F
	10	I51-2000H	I51-2001H		I51-2010H	I51-2011H
500	2.5	I51-2100D	I51-2101D		I51-2110D	I51-2111D
	5	I51-2100F	I51-2101F		I51-2110F	I51-2111F
	10	I51-2100H	I51-2101H		I51-2110H	I51-2111H
	15	I51-2100J	I51-2101J		I51-2110J	I51-2111J
600	2.5	I51-2200D	I51-2201D			I51-2211D
	5	I51-2200F	I51-2201F		I51-2210F	I51-2211F
	10	I51-2200H	I51-2201H		I51-2210H	I51-2211H
	15	I51-2200J	I51-2201J		I51-2210J	I51-2211J
750	2.5	I51-2300D	I51-2301D	V51-2304D	I51-2310D	
	5	I51-2300F	I51-2301F	V51-2304F	I51-2310F	I51-2311F
	10	I51-2300H	I51-2301H		I51-2310H	I51-2311H
	15	I51-2300J	I51-2301J		I51-2310J	I51-2311J
1000	5	I51-2500F	I51-2501F	V51-2504F	I51-2510F	I51-2511F
	10	I51-2500H	I51-2501H	V51-2504H	I51-2510H	I51-2511H
	15	I51-2500J	I51-2501J		I51-2510J	I51-2511J
	30	I51-2500L	I51-2501L		I51-2510L	I51-2511L
1200	5	I51-2600F	I51-2601F	V51-2604F	I51-2610F	I51-2611F
	10	I51-2600H	I51-2601H	V51-2604H	I51-2610H	I51-2611H
	15	I51-2600J	I51-2601J	V51-2604J	I51-2610J	I51-2611J
	30	I51-2600L	I51-2601L		I51-2610L	I51-2611L
1250	5	I51-2700F	I51-2701F	V51-2704F	I51-2710F	I51-2711F
	10	I51-2700H	I51-2701H	V51-2704H	I51-2710H	I51-2711H
	15	I51-2700J	I51-2701J	V51-2704J	I51-2710J	I51-2711J
	30	I51-2700L	I51-2701L		I51-2710L	I51-2711L
	45	I51-2700M				
1500	5	I51-2800F	I51-2801F	V51-2804F	I51-2810F	I51-2811F
	10	I51-2800H	I51-2801H	V51-2804H	I51-2810H	I51-2811H
	15	I51-2800J	I51-2801J	V51-2804J	I51-2810J	I51-2811J
	30	I51-2800L	I51-2801L		I51-2810L	I51-2811L
	45	I51-2800M				
1600	5	I51-2900F	I51-2901F	V51-2904F	I51-2910F	I51-2911F
	10	I51-2900H	I51-2901H	V51-2904H	I51-2910H	I51-2911H
	15	I51-2900J	I51-2901J	V51-2904J	I51-2910J	I51-2911J
	30	I51-2900L	I51-2901L		I51-2910L	I51-2911L
	45	I51-2900M				
2000	10	I51-3000H	I51-3001H	V51-3004H	I51-3010H	I51-3011H
	15	I51-3000J	I51-3001J	V51-3004J	I51-3010J	I51-3011J
	30	I51-3000L	I51-3001L		I51-3010L	I51-3011L
	45	I51-3000M	I51-3001M			
2400	10	I51-3100H	I51-3101H	V51-3104H	I51-3110H	I51-3111H
	15	I51-3100J	I51-3101J	V51-3104J	I51-3110J	I51-3111J
	30	I51-3100L	I51-3101L		I51-3110L	I51-3111L
	45	I51-3100M	I51-3101M			
2500	10	I51-3200H	I51-3201H	V51-3204H	I51-3210H	I51-3211H
	15	I51-3200J	I51-3201J	V51-3204J	I51-3210J	I51-3211J
	30	I51-3200L	I51-3201L	V51-3204L	I51-3210L	I51-3211L
	45	I51-3200M	I51-3201M			
3000	10	I51-3300H	I51-3301H	V51-3304H	I51-3310H	I51-3311H
	15	I51-3300J	I51-3301J	V51-3304J	I51-3310J	I51-3311J
	30	I51-3300L	I51-3301L	V51-3304L	I51-3310L	I51-3311L
	45	I51-3300M				
3200	10	I51-3400H	I51-3401H	V51-3404H	I51-3410H	I51-3411H
	15	I51-3400J	I51-3401J	V51-3404J	I51-3410J	I51-3411J
	30	I51-3400L	I51-3401L	V51-3404L	I51-3410L	I51-3411L
	45	I51-3400M			I51-3410M	



## Low voltage current transformers for industrial applications Wound current transformers

<b>WSK 30</b>	Transformer width	61 mm
<b>WSK 40</b>	Transformer width	71 mm
<b>WSK 40 N</b>	Transformer width	71 mm
<b>NEW</b>		
<b>WSK 60</b>	Transformer width	71 mm
<b>WSK 70.6</b>	Transformer width	60 mm
<b>WSK 70.6 N</b>	Transformer width	60 mm
<b>WSK 31.5</b>	Transformer width	70 mm

## Wound current transformers

Based on the physical operating principle of current transformers, the required core volume transferring an amount of power, increases rapidly with a decreasing nominal current. As there are limits on increasing the transformer size, wound current transformers are being used.

Interim current transformers also belong to the group of wound current transformers. This construction is mainly used for primary currents of up to 10 A, and achieves a transformation at a higher or lower secondary current values. In addition to their application in adapting a measuring circuit on existing measuring units, interim current transformers are being used also for lowering the power loss by the transmission of analogically measured values over great distances. This is made possible by means of a squared dependence of the power loss from the flowing current.

$$P_V = I^2 \times Z \text{ [VA]}$$

apparent power [VA]

This means when the original nominal current is halved, the conductor loss drops down to 25 % of its original value.

Indication: The selection of the nominal power of the initially activated main transformer is achieved through the application of the following measurement comparisons.

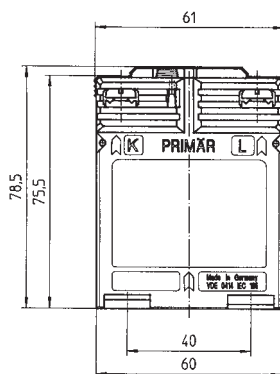
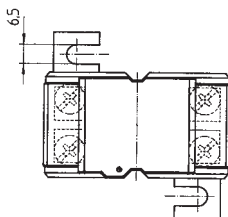
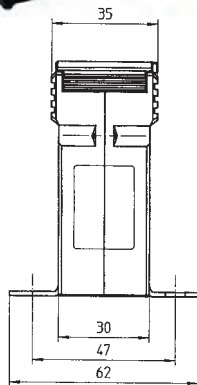
$$P_{GH} = P_Z \times \left(\frac{I_2}{I_1}\right)^2 + P_E + P_{HZ}$$

- $P_{GH}$     apparent power of the main transformer
- $P_Z$      secondary performance of the interim transformer (nominal performance inclusive of conductor losses)
- $P_E$      consumption of the interim transformer by nominal current
- $P_{HZ}$     conductor losses between main- and interim transformer by nominal current
- $I_1$      primary nominal current of the interim transformer
- $I_2$      secondary nominal current of the interim transformer

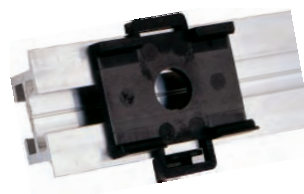


# WSK 30

Wound current transformer



Secondary current		5A		1A	
Primary current A	Burden VA	Accuracy class		Accuracy class	
		1	0.5	1	0.5
		Art.-no.	Art.-no.	Art.-no.	Art.-no.
1	2.5	30017	30011	30217	30211
	5	30018		30218	
2.5	2.5	30019	30012	30219	30212
	5	30020		30220	
5	2.5	30021	30013	30221	30213
	5	30022		30222	
10	2.5	30023	30014	30223	30214
	5	30024		30224	
15	2.5	30025	30015	30225	30215
	5	30026		30226	
20	2.5	30027	30016	30227	30216
	5	30028		30228	



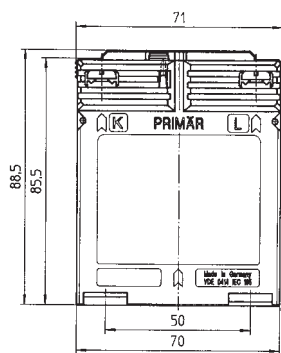
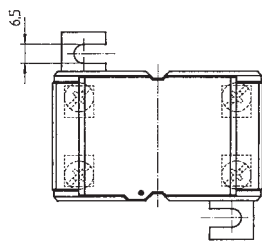
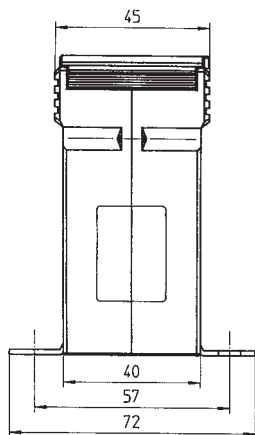
Snap-on mounting

Primary conductor	—
Round conductor	—
Transformer width	61 mm
Snap-on mounting	<b>Art.-no. 53011</b> see page 206
Sealed shutter	<b>Art.-no. 59040</b> see page 207

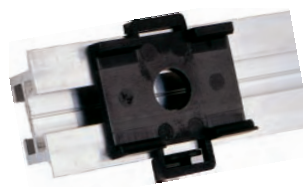


# WSK 40

Wound current transformer



Secondary current		5A		1A	
Primary current A	Burden VA	Accuracy class		Accuracy class	
		1	0.5	1	0.5
		Art.-no.	Art.-no.	Art.-no.	Art.-no.
1	2.5	31044	31011	31244	31211
	5	31045	31012	31245	31212
	10	31046	31013	31246	31213
	15	31047	31014	31247	31214
2.5	2.5	31048	31015	31248	31215
	5	31049	31016	31249	31216
	10	31050	31017	31250	31217
	15	31051	31018	31251	31218
5	2.5	31052	31019	31252	31219
	5	31053	31020	31253	31220
	10	31054	31021	31254	31221
	15	31055	31022	31255	31222
10	2.5	31056	31023	31256	31223
	5	31057	31024	31257	31224
	10	31058	31025	31258	31225
	15	31059	31026	31259	31226
15	2.5	31060	31027	31260	31227
	5	31061	31028	31261	31228
	10	31062	31029	31262	31229
	15	31063	31030	31263	31230
20	2.5	31064	31031	31264	31231
	5	31065	31032	31265	31232
	10	31066	31033	31266	31233
	15	31067	31034	31267	31234
25	2.5	31068	31035	31268	31235
	5	31069	31036	31269	31236
	10	31070	31037	31270	31237
	15	31071	31038	31271	31238
30	2.5	31072	31039	31272	31239
	5	31073	31040	31273	31240
	10	31074	31041	31274	31241



Snap-on mounting

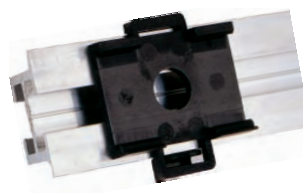
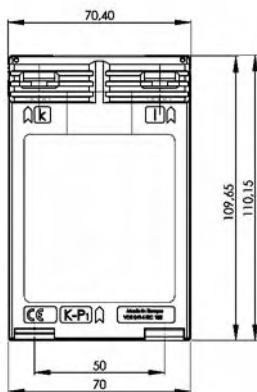
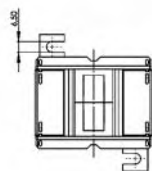
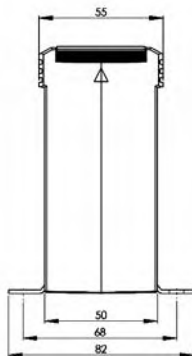
Primary conductor	—
Round conductor	—
Transformer width	71 mm
Snap-on mounting	<b>Art.-no. 55012</b> see page 206
Sealed shutter	<b>Art.-no. 59041</b> see page 207



# WSK 40 N

Wound current transformer

Secondary current		5A		1A	
Primary current A	Burden VA	Accuracy class		Accuracy class	
		1	0.5	1	0.5
		Art.-no.	Art.-no.	Art.-no.	Art.-no.
30	2.5	31161	31151	31361	31351
	5	31162	31152	31362	31352
	10	31163	31153	31363	31353
40	2.5	31164	31154	31364	31354
	5	31165	31155	31365	31355
	10	31166	31156	31366	31356
50	2.5	31167	31157	31367	31357
	5	31168	31158	31368	31358
	10	31169	31159	31369	31359



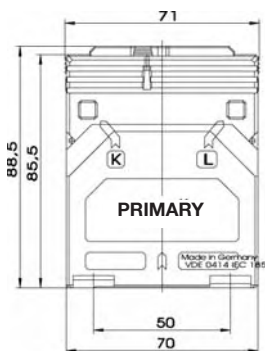
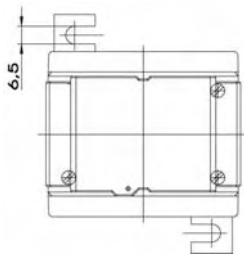
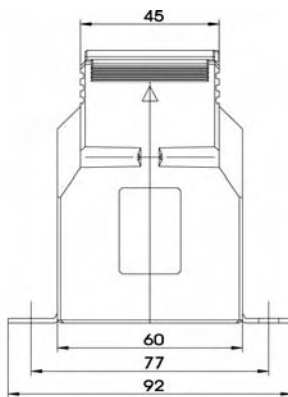
Snap-on mounting

Primary conductor	—
Round conductor	—
Transformer width	71 mm
Snap-on mounting	<b>Art.-no. 55011</b> see page 206
Sealed shutter	<b>Art.-no. 59041</b> see page 207



# WSK 60

Wound current transformer

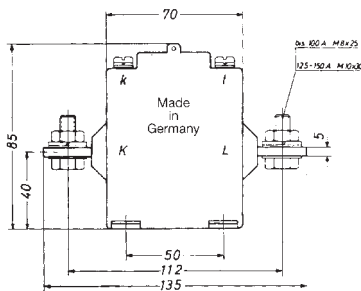
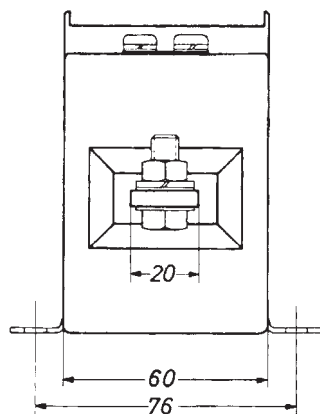


Secondary current		5A		1A	
Primary current A	Burden VA	Accuracy class		Accuracy class	
		1	0.5	1	0.5
		Art.-no.	Art.-no.	Art.-no.	Art.-no.
5	2.5	35041	35011	35241	35211
	5	35042	35012	35242	35212
	10	35043	35013	35243	35213
	15	35044		35244	
10	2.5	35045	35014	35245	35214
	5	35046	35015	35246	35215
	10	35047	35016	35247	35216
	15	35048		35248	
15	2.5	35049	35017	35249	35217
	5	35050	35018	35250	35218
	10	35051	35019	35251	35219
	15	35052		35252	
20	2.5	35053	35020	35253	35220
	5	35054	35021	35254	35221
	10	35055	35022	35255	35222
	15	35056		35256	
25	2.5	35057	35023	35257	35223
	5	35058	35024	35258	35224
	10	35059	35025	35259	35225
	15	35060		35260	
30	2.5	35061	35026	35261	35226
	5	35062	35027	35262	35227
	10	35063	35028	35263	35228
	15	35064		35264	

Primary conductor	—
Round conductor	—
Transformer width	71 mm
Snap-on mounting	—
Sealed shutter	<b>Art.-no. 59041</b> see page 207

# WSK 70.6

## Wound current transformer



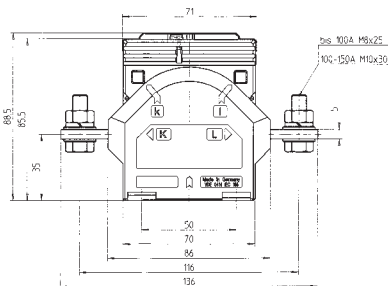
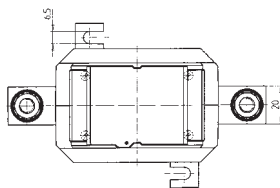
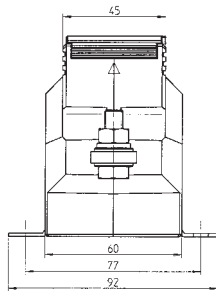
Secondary current		5A		1A	
Primary current A	Burden VA	Accuracy class		Accuracy class	
		1	0.5	1	0.5
		Art.-no.	Art.-no.	Art.-no.	Art.-no.
25	2.5	32038	32011	32238	32211
	5	32039	32012	32239	32212
	10	32040	32013	32240	32213
	15	32041		32241	
30	2.5	32042	32014	32242	32214
	5	32043	32015	32243	32215
	10	32044	32016	32244	32216
	15	32045		32245	
40	2.5	32046	32017	32246	32217
	5	32047	32018	32247	32218
	10	32048	32019	32248	32219
	15	32049		32249	
50	2.5	32050	32020	32250	32220
	5	32051	32021	32251	32221
	10	32052	32022	32252	32222
	15	32053		32253	
60	2.5	32054	32023	32254	32223
	5	32055	32024	32255	32224
	10	32056	32025	32256	32225
	15	32057		32257	
75	2.5	32058	32026	32258	32226
	5	32059	32027	32259	32227
	10	32060	32028	32260	32228
	15	32061		32261	
80	2.5	32062	32029	32262	32229
	5	32063	32030	32263	32230
	10	32064	32031	32264	32231
	15	32065		32265	
100	2.5	32066	32032	32266	32232
	5	32067	32033	32267	32233
	10	32068	32034	32268	32234
	15	32069		32269	

Primary conductor	—
Round conductor	—
Transformer width	60 mm
Snap-on mounting	—
Sealed shutter	<b>Art.-no. 59043</b> see page 207



# WSK 70.6 N

Wound current transformer

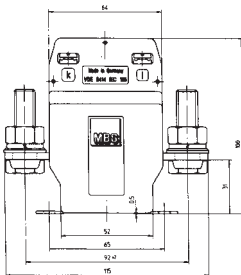
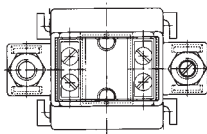
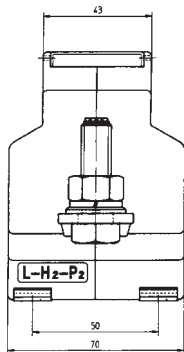
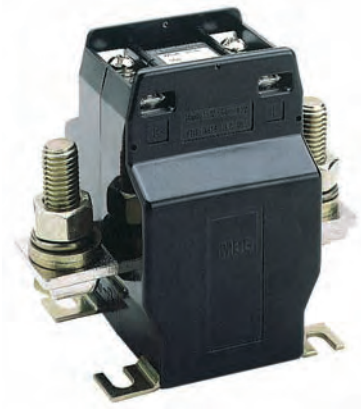


Secondary current		5A		1A	
Primary current A	Burden VA	Accuracy class		Accuracy class	
		1	0.5	1	0.5
		Art.-no.	Art.-no.	Art.-no.	Art.-no.
25	2.5	89047	89011	89247	89211
	5	89048	89012	89248	89212
	10	89049	89013	89249	89213
	15	89050		89250	
30	2.5	89051	89015	89251	89215
	5	89052	89016	89252	89216
	10	89053	89017	89253	89217
	15	89054		89254	
40	2.5	89055	89019	89255	89219
	5	89056	89020	89256	89220
	10	89057	89021	89257	89221
	15	89058		89258	
50	2.5	89059	89023	89259	89223
	5	89060	89024	89260	89224
	10	89061	89025	89261	89225
	15	89062		89262	
60	2.5	89063	89027	89263	89227
	5	89064	89028	89264	89228
	10	89065	89029	89265	89229
	15	89066		89266	
75	2.5	89067	89031	89267	89231
	5	89068	89032	89268	89232
	10	89069	89033	89269	89233
	15	89070		89270	
80	2.5	89071	89035	89271	89235
	5	89072	89036	89272	89236
	10	89073	89037	89273	89237
	15	89074		89274	
100	2.5	89075	89039	89275	89239
	5	89076	89040	89276	89240
	10	89077	89041	89277	89241
	15	89078		89278	

Primary conductor	—
Round conductor	—
Transformer width	60 mm
Snap-on mounting	—
Sealed shutter	<b>Art.-no. 59041</b> see page 207

# WSK 31.5

## Wound current transformer



Secondary current		5A		1A	
Primary current A	Burden VA	Accuracy class		Accuracy class	
		1	0.5	1	0.5
		Art.-no.	Art.-no.	Art.-no.	Art.-no.
25	2.5	33047	33011	33247	33211
	5	33048	33012	33248	33212
	10	33049	33013	33249	33213
	15	33050	33014	33250	33214
30	2.5	33051	33015	33251	33215
	5	33052	33016	33252	33216
	10	33053	33017	33253	33217
	15	33054	33018	33254	33218
40	2.5	33055	33019	33255	33219
	5	33056	33020	33256	33220
	10	33057	33021	33257	33221
	15	33058	33022	33258	33222
50	2.5	33059	33023	33259	33223
	5	33060	33024	33260	33224
	10	33061	33025	33261	33225
	15	33062	33026	33262	33226
60	2.5	33063	33027	33263	33227
	5	33064	33028	33264	33228
	10	33065	33029	33265	33229
	15	33066	33030	33266	33230
75	2.5	33067	33031	33267	33231
	5	33068	33032	33268	33232
	10	33069	33033	33269	33233
	15	33070	33034	33270	33234
80	2.5	33071	33035	33271	33235
	5	33072	33036	33272	33236
	10	33073	33037	33273	33237
	15	33074	33038	33274	33238
100	2.5	33075	33039	33275	33239
	5	33076	33040	33276	33240
	10	33077	33041	33277	33241
	15	33078	33042	33278	33242
150	2.5	33079	33043	33279	33243
	5	33080	33044	33280	33244
	10	33081	33045	33281	33245
	15	33082	33046	33282	33246



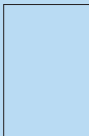
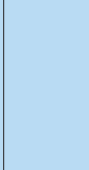
Primary conductor	—
Round conductor	—
Transformer width	70 mm
Snap-on mounting	—
Sealed shutter	<b>Art.-no. 59045</b> see page 207
Current transformer for tariff applications	see page 196

## Split core current transformers, series KBU



[www.mbs-ag.com](http://www.mbs-ag.com)

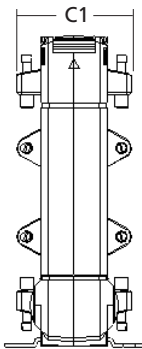
# Split core current transformers

<b>KBU 23</b>	Primary conductor Transformer width		20 x 30 mm 93 mm
<b>KBU 58</b>	Primary conductor Transformer width		50 x 80 mm 125 mm
<b>KBU 812</b>	Primary conductor Transformer width		80 x 120 mm 155 mm
<b>KBU 816</b>	Primary conductor Transformer width		80 x 160 mm 195 mm



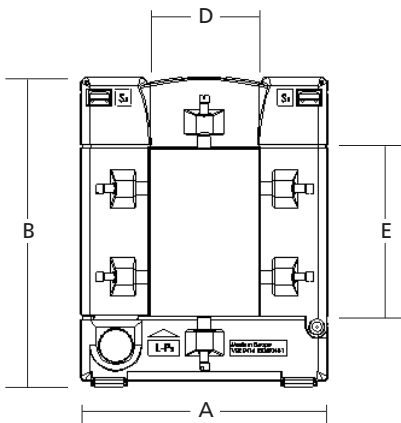
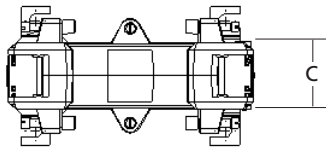
# KBU 23

Split core current transformer



Secondary current		5A		1A	
Primary current A	Burden VA	Accuracy class		Accuracy class	
		1	0.5	1	0.5
		Art.-no.	Art.-no.	Art.-no.	Art.-no.
100	1.25	80041		80241	
150	1.5	80042		80242	
200	1.5	80043		80243	
250	1.5	80044		80244	
300	1.5		80035		80235
	3.75	80045		80245	
400	2.5		80036		80236
	5	80046		80246	

# KBU 58

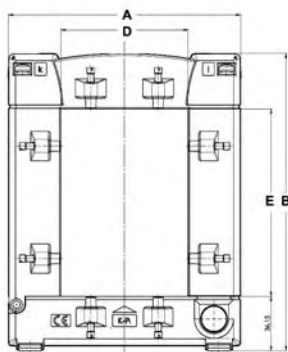
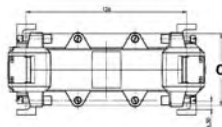
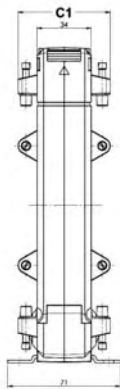
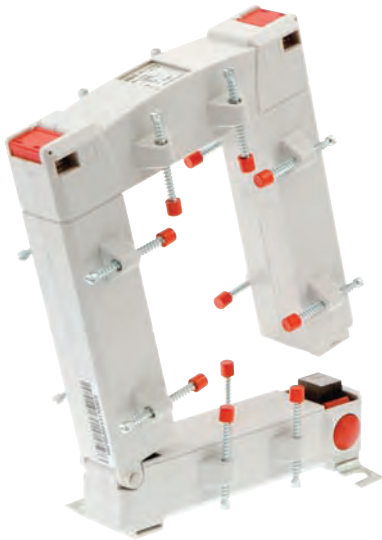


Secondary current		5A		1A	
Primary current A	Burden VA	Accuracy class		Accuracy class	
		1	0.5	1	0.5
		Art.-no.	Art.-no.	Art.-no.	Art.-no.
250	1		80051		80251
	1.5	80061		80261	
300	1.5		80052		80252
	2.5	80062		80262	
400	1.5		80053		80253
	2.5	80063		80263	
500	2.5		80054		80254
	5	80064		80264	
600	2.5		80055		80255
	5	80065		80265	
750	2.5		80056		80256
	5	80066		80266	
800	2.5		80057		80257
	7.5	80067		80267	
1000	5		80058		80258
	10	80068		80268	

Type	KBU 23	KBU 58
A	93	125
B	106	158
C/C1	34/58	34/58
D	20	50
E	30	80

# KBU 812

Split core current transformer



Type	KBU 812	KBU 816
A	155	195
B	198	243
C/C1	34/58	64/79
D	80	80
E	120	160

Secondary current		5A		1A	
Primary current A	Burden VA	Accuracy class		Accuracy class	
		1	0.5	1	0.5
		Art.-no.	Art.-no.	Art.-no.	Art.-no.
250	1		80071		80271
	1.5	80091		80291	
300	1.5		80072		80272
	2.5	80092		80292	
400	1.5		80073		80273
	2.5	80093		80293	
500	2.5		80074		80274
	5	80094		80294	
600	2.5		80075		80275
	5	80095		80295	
750	2.5		80076		80276
	5	80096		80296	
800	2.5		80077		80277
	7.5	80097		80297	
1000	5		80078		80278
	10	80098		80298	
1200	5		80079		80279
	10	80099		80299	
1250	7.5		80080		80280
	15	80100		80300	
1500	7.5		80081		80281
	15	80101		80301	

# KBU 816

Secondary current		5A		1A	
Primary current A	Burden VA	Accuracy class		Accuracy class	
		1	0.5	1	0.5
		Art.-no.	Art.-no.	Art.-no.	Art.-no.
1000	10	80140	80110	80340	80310
	15	80141		80341	
1200	10	80142	80111	80342	80311
	15	80143		80343	
1500	10	80144	80112	80344	80312
	15	80145	80113	80345	80313
1600	10	80146	80114	80346	80314
	15	80147	80115	80347	80315
2000	10	80148	80116	80348	80316
	15	80149	80117	80349	80317
2500	10	80150	80119	80350	80319
	15	80151	80120	80351	80320
3000	15	80152	80122	80352	80322
	30	80153		80353	
4000	15	80154	80123	80354	80323
	30	80155	80124	80355	80324
5000	15	80156	80125	80356	80325
	30	80157	80126	80357	80326

## Summation current transformers, series KSU / SUSK



[www.mbs-ag.com](http://www.mbs-ag.com)

## Low voltage current transformers for industrial applications

### **KSU**      **Summation current transformer**

Transformer width

127 mm

Transformer depth

57 mm

---

### **SUSK**      **Summation current transformer**

Transformer width

156 mm

Transformer depth

65 mm

## Guidance when ordering summation current transformers

Summation current transformers are suitable for the summation of several synchronized alternating currents with similar phases but with differing load phase shifts. It is also possible to have the summation of currents with varied nominal voltages of similar phase positions. These measurements cannot be used for tariff applications, as the existing voltage differences are recorded as errors.

With the counter connection of the main transformer to the summation current transformer, it is possible to receive secondary currents which are proportional to the differences of the primary input currents.

The built-in technical know-how enables the summation current transformers to add secondary currents of varying nominal transmissions from the main transformer.

The secondary connections of each main transformer are connected to the allocated primary inputs of the summation current transformers.

The number of windings of individual partially wound primary circuits of the summation current transformer is proportionally aligned to the ratio of the primary nominal current of the corresponding main transformer, and to the sum of the nominal currents of all the summation current transformers being connected to the main transformer.

For the visual display of the current, a measuring unit can be used with a measuring range similar to the secondary nominal current of the summation current transformers.

It is irrelevant for the main transformers with similar nominal transmission ratios, to which primary circuit of the summation current transformer the connection is made.

With main transformers of different nominal transmission ratios, care must be taken to adhere to the assigned connection to the terminals of the summation current transformers.

If the current flow in the main transformer is interrupted, the secondary circuit of the main transformer must neither be short-circuited nor be connected to the summation current transformer, or to the main transformer.

Summation current transformers with unallocated primary circuits must remain open for a later connection to an additional main transformer. The secondary output current of the summation current transformer is in this instance lower than the secondary nominal current of the summation current transformer by a quantity equal to the ratio of the primary nominal current of this "missing" main transformer and the sum of all the primary nominal currents of the main transformer.

The nominal secondary current of a main transformer must be equal to the nominal primary current of the input allocation of the summation current transformer.

continuation see page 115

continuation from page 114

## Guidance when ordering summation current transformers

Please find below an example for the correct selection of measuring components for summation current transformers.

**Example:**

Actual situation:	3 transmission ratios	1000 / 5 VA
		800 / 5 VA
		<u>600 / 5 VA</u>
	Overall current	2400 / 5 VA

Burden: – 1 current meter  
– 1 power recorder

Looking for: 1 summation current transformer and the VA power of an individual main transformer

Required active performance of the summation current transformer:

Current meter	1.5 VA
Performance recorder	7.0 VA
Measurement conductor loss	1.5 VA
consumption P <sub>o</sub> summation ct	<u>4.0 VA</u>
Interim result	14.0 VA

The individual transformer must provide its VA share from this 14.0 VA corresponding to its ratio to the “total transmission”.

Consideration must also be given to the respective power loss between the main transformer and the summation transformer plus other possible losses.

1. Main transformer 1000 / 5A  $\frac{1000}{2400} \times 14.0 = 5.83 \text{ VA} + \text{additional possible losses}$
2. Main transformer 800 / 5A  $\frac{800}{2400} \times 14.0 = 4.67 \text{ VA} + \text{additional possible losses}$
3. Main transformer 600 / 5A  $\frac{600}{2400} \times 14.0 = 3.50 \text{ VA} + \text{additional possible losses}$

The VA values of the main transformers are to be rounded up to the corresponding VA values in our charts.

**The ratio of the primary current of a main transformer to the sum of the primary currents of all main current transformers the ratio must not exceed 1:8.**

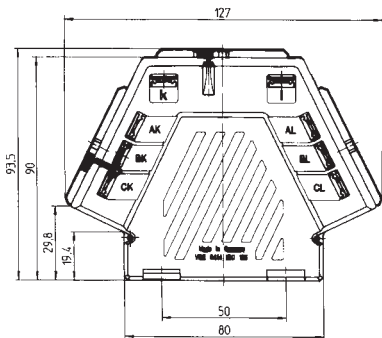
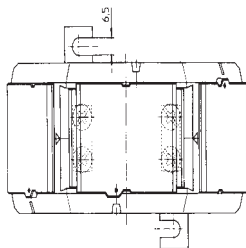
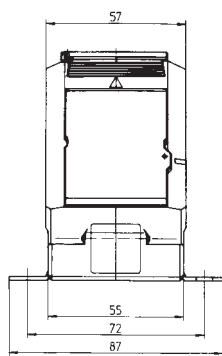
### Important indication to the power measuring

Too many rising deviation can prevent the measuring transformer acting as a current transformer from fulfilling its protective function with regard to the connected measuring units, as in normal operation its functions is well below its saturation limit, and in the event of over currents, the saturation limit is reached considerably later and takes the function almost as a protection current transformer.

If there is too much of a decrease, the measuring transformer, as a result of the continuous excess demands will reach the saturation limit too soon and indirectly function as a switch, rendering a measuring impossible.

# KSU 2...3

## Summation current transformer

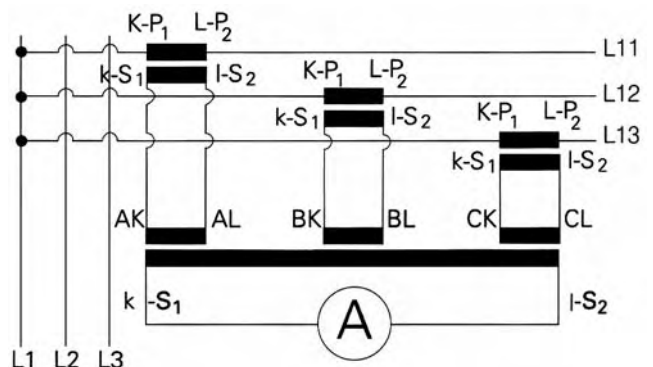


Type	Primary current A	Burden VA	5A		1A	
			Accuracy class		Accuracy class	
			1	0.5	1	0.5
			Art.-no.	Art.-no.	Art.-no.	Art.-no.
2	1+1	5	41114	41111	41314	41311
		10	41115	41112	41315	41312
		15	41116	41113	41316	41313
		20	41117		41317	
		25	41118		41318	
		30	41119		41319	
3	1+1+1	5	41130	41127	41330	41327
		10	41131	41128	41331	41328
		15	41132	41129	41332	41329
		30	41133		41333	
2	5+5	5	41014	41011	41214	41211
		10	41015	41012	41215	41212
		15	41016	41013	41216	41213
		20	41017		41217	
		25	41018		41218	
		30	41019		41219	
3	5+5+5	5	41030	41027	41230	41227
		10	41031	41028	41231	41228
		15	41032	41029	41232	41229
		30	41033		41233	

Connection example for different ratios:

- AK-AL = 1000/5
- BK-BL = 800/5
- CK-CL = 600/5

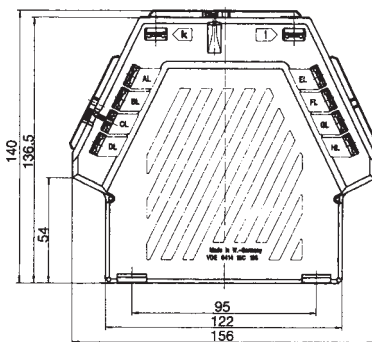
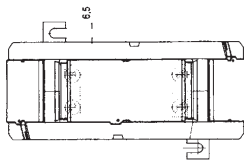
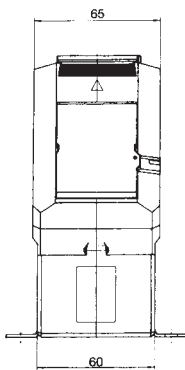
Connection diagram



Primary conductor	—
Round conductor	—
Transformer width	127 mm
Transformer depth	57 mm
Snap-on mounting	—
Sealed shutter	Art.-no. 59041
2 pieces primary	see page 207

# SUSK 3...8

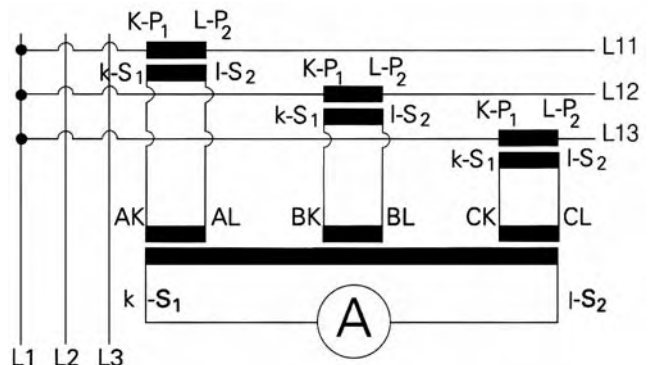
## Summation current transformer



Type	Primary current A	Burden VA	5A		1A	
			Accuracy class		Accuracy class	
			1	0.5	1	0.5
			Art.-no.	Art.-no.	Art.-no.	Art.-no.
3	5+5+5	5	40015	40011	40215	40211
		10	40016	40012	40216	40212
		15	40017	40014	40217	40214
		30	40018		40218	
4	5+5+5+5	5	40026	40023	40226	40223
		10	40027	40024	40227	40224
		15	40028	40025	40228	40225
		25	40029		40229	
		30	40030		40230	
5	5+5+5+5+5	5	40037	40034	40237	40234
		10	40038	40035	40238	40235
		15	40039	40036	40239	40236
		30	40040		40240	
6	5+5+5+5+5+5	5	40048	40045	40248	40245
		10	40049	40046	40249	40246
		15	40050	40047	40250	40247
		30	40051		40251	
7	5+5+5+5+5+5+5	5	40060	40057	40260	40257
		10	40061	40058	40261	40258
		15	40062	40059	40262	40259
		30	40063		40263	
8	5+5+5+5+5+5+5+5	5	40071	40068	40271	40268
		10	40072	40069	40272	40269
		15	40073	40070	40273	40270
		30	40074		40274	

Primary current 1 A, see page 116.

Connection diagram

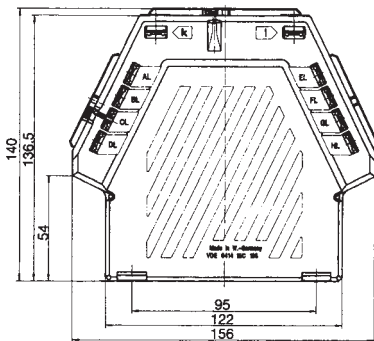
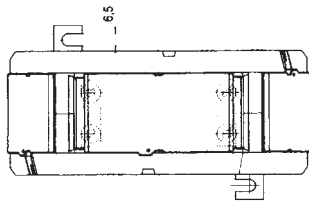
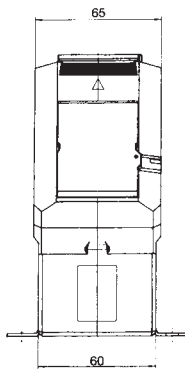


Primary conductor	—
Round conductor	—
Transformer width	156 mm
Transformer depth	65 mm
Snap-on mounting	—
Sealed shutter secondary no.	Art.-no. 59041 (primary) Art.-no. 59042 (secondary) see page 207
Current transformer for tariff applications	see page 197



# SUSK 3...8

Summation current transformer



Typ	Primary current A	Burden VA	5A		1A	
			Accuracy class		Accuracy class	
			1	0.5	1	0.5
			Art.-no.	Art.-no.	Art.-no.	Art.-no.
3	1+1+1	5	40115	40111	40315	40311
		10	40116	40112	40316	40312
		15	40117	40114	40317	40314
		30	40118	40318		
4	1+1+1+1	5	40126	40123	40326	40323
		10	40127	40124	40327	40324
		15	40128	40125	40328	40325
		25	40129	40329		
		30	40130	40330		
5	1+1+1+1+1	5	40137	40134	40337	40334
		10	40138	40135	40338	40335
		15	40139	40136	40339	40336
		30	40140	40340		
6	1+1+1+1+1+1	5	40148	40145	40348	40345
		10	40149	40146	40349	40346
		15	40150	40147	40350	40347
		30	40151	40351		
7	1+1+1+1+1+1+1	5	40160	40157	40360	40357
		10	40161	40158	40361	40358
		15	40162	40159	40362	40359
		30	40163	40363		
8	1+1+1+1+1+1+1+1	5	40171	40168	40371	40368
		10	40172	40169	40372	40369
		15	40173	40170	40373	40370
		30	40174	40374		

Primary current 5 A, see page 117

Connection example for different ratios:

- AK-AL = 1000/5
- BK-BL = 800/5
- CK-CL = 600/5
- DK-DL = 400/5
- EK-EL = 400/5
- FK-FL = 300/5
- GK-GL = 300/5
- HK-HL = 300/5

Primary conductor	—
Round conductor	—
Transformer width	156 mm
Transformer depth	65 mm
Snap-on mounting	—
Sealed shutter secondary no.	<b>Art.-no. 59041</b> (primary) <b>Art.-no. 59042</b> (secondary) see page 207
Current transformer for tariff applications	see page 197

**Low voltage current transformers  
for industrial applications  
Special current transformers**

**NH      Current transformers for fuse rails**

---

# NH-Current transformers for fuse rails

## Size 1, 2 and 3

**Housing material:** Technyl A20 V25 N025. 200 °C

**Configuration:** Current transformers for direct fitment in connection with low voltage high performance fuses with contact-knives and NH-fuse sets according to DIN 43620/1. NH current transformers are arranged with 2 or 4 tip jacks respectively and can be operated continuously in open state. Loss motion voltage / open circuit voltage with sec. 5 A approx. 3–6 V and with sec. 1 A approx. 13–25 V. The current transformers can also be supplied in dual change-over mode for secondary application.

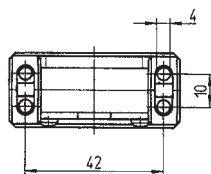




# NH 6.1

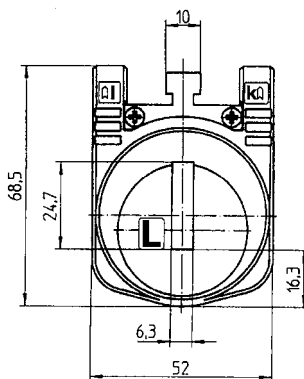
Current transformer for fuse rails

Secondary current		5A	1A
Primary current A	Burden VA	Accuracy class	Accuracy class
		3	3
		Art.-no.	Art.-no.
100	1.25	50011	50211
150	2.5	50012	50212
200	3.5	50013	50213
250	4	50014	50214
300	5	50015	50215



# NH 6.1 2u

Secondary current		5A	1A
Primary current A	Burden VA	Accuracy class	Accuracy class
		3	3
		Art.-no.	Art.-no.
200-100	2.5-1.25	50111	50311
300-150	5-2.5	50112	50312



Primary conductor	24 x 6 mm
Round conductor	—
Transformer width	52 mm
Snap-on mounting	—
Sealed shutter	—

# NH 6.2

Current transformer for fuse rails

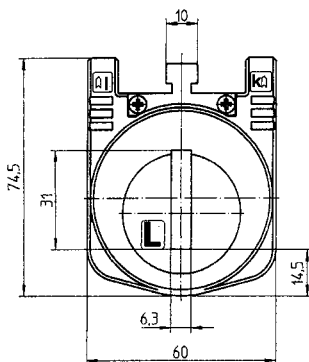
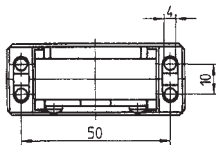


Secondary current		5A	1A
Primary current A	Burden VA	Accuracy class	Accuracy class
		3	3
		Art.-no.	Art.-no.
100	1.25	50021	50221
150	2.5	50022	50222
200	3.5	50023	50223
250	4	50024	50224
300	5	50025	50225
400	5	50026	50226



# NH 6.2 2u

Secondary current		5A	1A
Primary current A	Burden VA	Accuracy class	Accuracy class
		3	3
		Art.-no.	Art.-no.
200-100	2.5-1.25	50121	50321
300-150	5-2.5	50122	50322
400-200	5-2.5	50123	50323



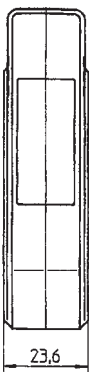
Primary conductor	30 x 6 mm
Round conductor	—
Transformer width	60 mm
Snap-on mounting	—
Sealed shutter	—

# NH 6.3

Current transformer for fuse rails

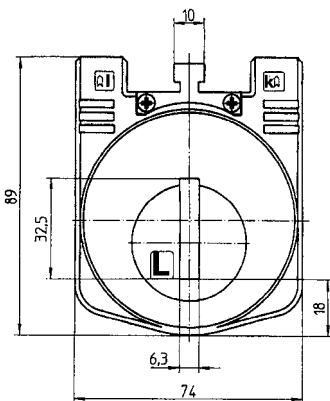
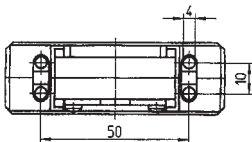


Secondary current		5A	1A
Primary current A	Burden VA	Accuracy class	Accuracy class
		3	3
		Art.-no.	Art.-no.
150	2.5	50031	50231
200	3.5	50032	50232
250	4	50033	50233
300	5	50034	50234
400	5	50035	50235
500	5	50036	50236
600	10	50037	50237



# NH 6.3 2u

Secondary current		5A	1A
Primary current A	Burden VA	Accuracy class	Accuracy class
		3	3
		Art.-no.	Art.-no.
300-150	5-2.5	50131	50331
400-200	5-2.5	50132	50332
600-300	10-5	50133	50333



Primary conductor	32 x 6 mm
Round conductor	—
Transformer width	74 mm
Snap-on mounting	—
Sealed shutter	—

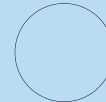


# Low voltage current transformers for industrial applications

## Protection tube current transformers

**SASR 22.3**

Round conductor  
Transformer width

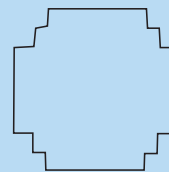


Ø 22.5 mm  
61 mm

## Protection plug-in current transformers

**SASK 21.3**

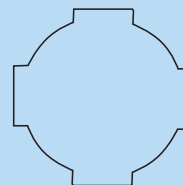
Primary conductor  
Round conductor  
Transformer width



20 x 10 mm  
Ø 19.2 mm  
61 mm

**SASK 31.5**

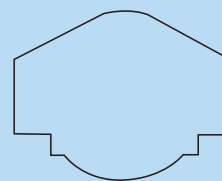
Primary conductor  
  
Round conductor  
Transformer width



30 x 10 mm  
2 x 20 x 10 mm  
Ø 28 mm  
61 mm

**SASK 31.6**

Primary conductor  
  
Round conductor  
Transformer width



30 x 10 mm  
20 x 13 mm  
Ø 23 mm  
95 mm

## Protection current transformers – Technical concepts

**Application:** Current transformers are for the galvanic separation, proportional transformation of alternating currents of larger currents into smaller, direct measurable values. There are two categories subject to their application:

- measuring transformers
- protection transformers.

All current transformers manufactured by MBS are for low voltage applications with a max. phase to phase voltage of 0.72 kV.

**Measuring transformer:** Measuring transformers are used to measure current, power, power factor and energy consumption combined with an equivalent measurement unit. Using its magnetic circle, current transformers allow a high transmission accuracy in the nominal current range, whilst simultaneously protecting the connected appliances against over current. The magnetic saturation in the measuring core ensures protection in the event of an over current.

**Protection current transformers:** Protection current transformers are for the control of protecting relays which have the task to separate switched circuits in the event of over current. For a safe function of these relays a proportional transfer ratio of the transformer up to a multiple of the nominal current is necessary. The dimensioning of this transformer unit secures a proportional current transfer, up to a multiple of the nominal currents, determined by the protection class.

**Technical standards:** All MBS current transformers are produced in accordance with the technical requirements of DIN EN 60044/1 (edition 12/2003)

**Technical characteristics:** Application use: Indoors, without condensation

**Protection current transformers:**

- Ambient temperature: - 5 °C ....+ 40 °C
- Housing material: Polycarbonate, self-extinguishing
- Housing form: halve-cup-shaped, ultrasonically welded
- Isolation class: E
- Thermal rated nominal continuous current:  $1.2 \times I_N$
- Secondary rated currents: 5 A or 1 A
- Thermal rated short time current:  $60 \times I_N$  (max.100 kA)
- Max. excess temperature of the secondary winding: 75 °C
- Isolating test voltage:  $3 \text{ kV } U_{\text{EFF}}$ ; 50 Hz, 1 min

**Safety instructions:** The protection current transformer's physical characteristics has its many advantages and with all these built-in features it is very easy to attend to this transformer with their secondary circuits open. This can be very harmful to the operator or transformers as multiple kilovolt surges can occur. In order to prevent any mishaps an operation as described above is forbidden.

**Ordering instructions:** For the correct processing of your order, please make available the following specification:

Transformer type  
Transmission ratio  
Accuracy class  
Rated burden

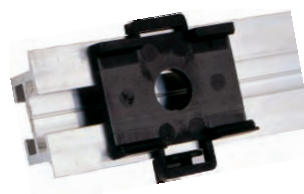
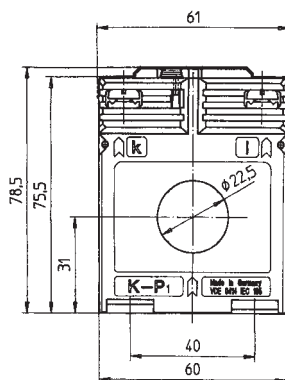
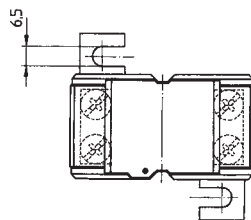
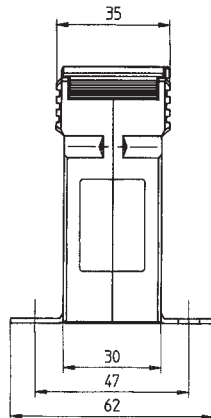
Accuracy classes of current transformers:													
Class	current error (+/- %) by % $I_N$						phase displacement error (+/- minutes) by % $I_N$						total error by $n \times I_N$ %
	1	5	20	50	100	120	1	5	20	50	100	120	
<b>Measuring transformer</b>													
0.2s	0.75	0.35	0.20	-	0.20	0.20	30	15	10	-	10	10	> 10
0.2	-	0.75	0.35	-	0.20	0.20	-	30	15	-	10	10	> 10
0.5s	1.50	0.75	0.50	-	0.50	0.50	90	45	30	-	30	30	> 10
0.5	-	1.50	0.75	-	0.50	0.50	-	90	45	-	30	30	> 10
1	-	3.00	1.50	-	1.00	1.00	-	180	90	-	60	60	> 10
3	-	-	3.00	3.00	3.00	3.00	-	-	-	120	120	120	> 10
<b>Protection current transformer</b>													
5P(n)	-	3.00	1.50	-	1.00	1.00	-	180	90	-	60	60	< 5
10P(n)	-	-	-	3.00	3.00	3.00	-	-	-	120	120	120	< 10
<b>n... over current rated limiting factor</b>													



# SASR 22.3

Protection tube current transformer

Secondary current		5A		1A	
Primary current A	Burden VA	Protection class		Protection class	
		5P5 Art.-no.	10P5 Art.-no.	5P5 Art.-no.	10P5 Art.-no.
100	1				S04-1317B
125	1	S04-1506B	S04-1507B		
	1.5			S04-1516C	S04-1517C
150	1	S04-1606B	S04-1607B		
	1.5			S04-1616C	S04-1617C
200	1	S04-1706B	S04-1707B		
	1.5			S04-1716C	S04-1717C
250	1	S04-1806B	S04-1807B		
	1.5			S04-1816C	S04-1817C
300	1	S04-1906B	S04-1907B		
	1.5		S04-1907C	S04-1916C	S04-1917C



Snap-on mounting

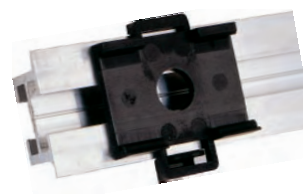
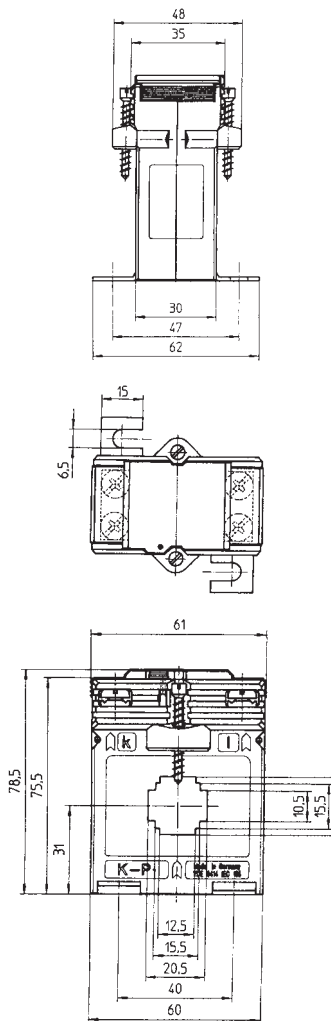
Primary conductor	—
Round conductor	Ø 22.5 mm
Transformer width	61 mm
Snap-on mounting	<b>Art.-no. 53011</b> see page 206
Sealed shutter	<b>Art.-no. 59040</b> see page 207
Current transformer for industrial application	see page 35
Current transformer for tariff applications	see page 169



# SASK 21.3

Protection plug-in current transformer

Secondary current		5A		1A	
Primary current A	Burden VA	Protection class		Protection class	
		5P5 Art.-no.	10P5 Art.-no.	5P5 Art.-no.	10P5 Art.-no.
125	1	S03-1506B	S03-1507B	S03-1516C	S03-1517C
	1.5				
150	1	S03-1606B	S03-1607B	S03-1616C	S03-1617C
	1.5				
200	1	S03-1706B	S03-1707B	S03-1716C	S03-1717C
	1.5				



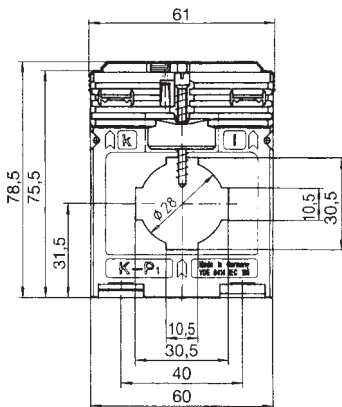
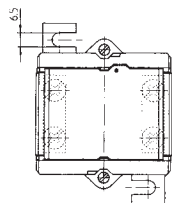
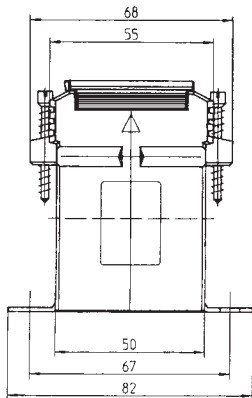
Snap-on mounting

Primary conductor	20 x 10 mm
Round conductor	Ø 19.2 mm
Transformer width	61 mm
Snap-on mounting	<b>Art.-no. 55014</b> see page 206
Sealed shutter	<b>Art.-no. 59040</b> see page 207
Current transformer for industrial applications	see page 45
Current transformer for tariff applications	see page 170

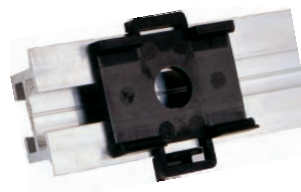


# SASK 31.5

Protection plug-in current transformer



Secondary current		5A		1A	
Primary current A	Burden VA	Protection class		Protection class	
		5P5 Art.-no.	10P5 Art.-no.	5P5 Art.-no.	10P5 Art.-no.
75	1			S17-1116B	S17-1117B
80	1			S17-1216B	S17-1217B
100	1	S17-1306B	S17-1307B		
	1.5			S17-1316C	S17-1317C
125	1	S17-1506B	S17-1507B		
	1.5		S17-1507C	S17-1516C	S17-1517C
150	1	S17-1606B	S17-1607B		
	1.5	S17-1606C	S17-1607C	S17-1616C	S17-1617C
200	1	S17-1706B	S17-1707B		
	1.5	S17-1706C	S17-1707C	S17-1716C	S17-1717C
	2.5			S17-1716D	S17-1717D
250	1.5	S17-1806C	S17-1807C	S17-1816C	S17-1817C
	2.5	S17-1806D	S17-1807D	S17-1816D	S17-1817D
300	1.5	S17-1906C	S17-1907C	S17-1916C	S17-1917C
	2.5	S17-1906D	S17-1907D	S17-1916D	S17-1917D
400	1.5	S17-2006C	S17-2007C	S17-2016C	S17-2017C
	2.5	S17-2006D	S17-2007D	S17-2016D	S17-2017D
500	1.5	S17-2106C	S17-2107C	S17-2116C	S17-2117C
	2.5	S17-2106D	S17-2107D	S17-2116D	S17-2117D
600	1.5	S17-2206C	S17-2207C	S17-2216C	S17-2217C
	2.5			S17-2216D	S17-2217C
750	1.5	S17-2306C	S17-2307C	S17-2316C	S17-2317C
	2.5			S17-2316D	S17-2317D
	5				S17-2317F



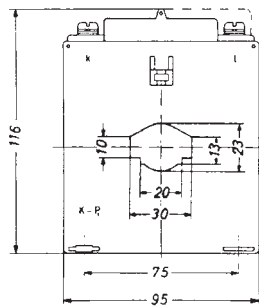
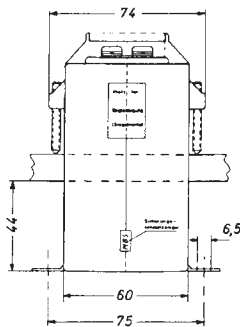
Snap-on mounting

Primary conductor	30 x 10 mm 2 x 20 x 10 mm
Round conductor	Ø 28 mm
Transformer width	61 mm
Snap-on mounting	<b>Art.-no. 55011</b> see page 206
Sealed shutter	<b>Art.-no. 59041</b> see page 207
Current transformer for industrial applications	see page 51
Current transformer for tariff applications	see page 173



# SASK 31.6

Protection plug-in current transformer



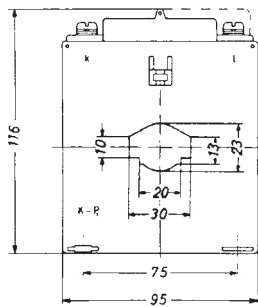
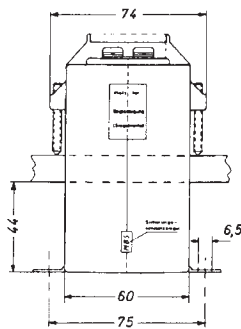
Secondary current		5A			
Primary current A	Burden VA	Protection class			
		5P5 Art.-no.	10P5 Art.-no.	5P10 Art.-no.	10P10 Art.-no.
50	1.5	S19-0906C	S19-0907C		
	2.5	S19-0906D	S19-0907D		
60	1.5	S19-1006C	S19-1007C		S19-1009C
	2.5	S19-1006D	S19-1007D		
80	1.5	S19-1206C	S19-1207C	S19-1208C	S19-1209C
	2.5	S19-1206D	S19-1207D		
100	1.5	S19-1306C	S19-1307C	S19-1308C	S19-1309C
	2.5	S19-1306D	S19-1307D		S19-1309D
	5	S19-1306F	S19-1307F		
150	2.5	S19-1606D	S19-1607D	S19-1608D	S19-1609D
	5	S19-1606F	S19-1607F		
	7.5	S19-1606G	S19-1607G		
200	2.5	S19-1706D	S19-1707D	S19-1708D	S19-1709D
	5	S19-1706F	S19-1707F		S19-1709F
	7.5	S19-1706G	S19-1707G		
	10	S19-1706H	S19-1707H		
250	2.5	S19-1806D	S19-1807D	S19-1808D	S19-1809D
	5	S19-1806F	S19-1807F	S19-1808F	S19-1809F
	7.5	S19-1806G	S19-1807G		
	10	S19-1806H	S19-1807H		
300	2.5	S19-1906D	S19-1907D	S19-1908D	S19-1909D
	5	S19-1906F	S19-1907F	S19-1908F	S19-1909F
	10	S19-1906H	S19-1907H		
400	2.5	S19-2006D	S19-2007D	S19-2008D	S19-2009D
	5	S19-2006F	S19-2007F	S19-2008F	S19-2009F
	7.5	S19-2006G	S19-2007G		
	10	S19-2006H	S19-2007H		
	15	S19-2006J	S19-2007J		
500	2.5	S19-2106D	S19-2107D	S19-2108D	S19-2109D
	5	S19-2106F	S19-2107F	S19-2108F	S19-2109F
	7.5	S19-2106G	S19-2107G	S19-2108G	S19-2109G
	10	S19-2106H	S19-2107H		
	15	S19-2106J	S19-2107J		
600	2.5	S19-2206D	S19-2207D	S19-2208D	S19-2209D
	5	S19-2206F	S19-2207F	S19-2208F	S19-2209F
	7.5	S19-2206G	S19-2207G	S19-2208G	S19-2209G
	10	S19-2206H	S19-2207H		S19-2209H
	15	S19-2206J	S19-2207J		

Primary conductor	30 x 10 mm 20 x 13 mm
Round conductor	Ø 23 mm
Transformer width	95 mm
Snap-on mounting	—
Sealed shutter	<b>Art.-no. 59044</b> see page 207
Current transformer for industrial applications	see page 53
Current transformer for tariff applications	see page 174



# SASK 31.6

Protection plug-in current transformer



Secondary current		1A			
Primary current A	Burden VA	Protection class			
		5P5 Art.-no.	10P5 Art.-no.	5P10 Art.-no.	10P10 Art.-no.
50	1.5	S19-0916C	S19-0917C		
	2.5	S19-0916D	S19-0917D		
60	1.5	S19-1016C	S19-1017C	S19-1018C	S19-1019C
	2.5	S19-1016D	S19-1017D		
80	1.5	S19-1216C	S19-1217C	S19-1218C	S19-1219C
	2.5	S19-1216D	S19-1217D		
	5		S19-1217F		
100	2.5	S19-1316D	S19-1317D	S19-1318D	S19-1319D
	5	S19-1316F	S19-1317F		
150	2.5	S19-1616D	S19-1617D	S19-1618D	S19-1619D
	5	S19-1616F	S19-1617F		
	7.5	S19-1616G	S19-1617G		
200	2.5	S19-1716D	S19-1717D	S19-1718D	S19-1719D
	5	S19-1716F	S19-1717F	S19-1718F	S19-1719F
	7.5	S19-1716G	S19-1717G		
	10	S19-1716H	S19-1717H		
250	2.5	S19-1816D	S19-1817D	S19-1818D	S19-1819D
	5	S19-1816F	S19-1817F	S19-1818F	S19-1819F
	7.5	S19-1816G	S19-1817G		
	10	S19-1816H	S19-1817H		
300	2.5	S19-1916D	S19-1917D	S19-1918D	S19-1919D
	5	S19-1916F	S19-1917F	S19-1918F	S19-1919F
	10	S19-1916H	S19-1917H		
400	2.5	S19-2016D	S19-2017D	S19-2018D	S19-2019D
	5	S19-2016F	S19-2017F	S19-2018F	S19-2019F
	7.5	S19-2016G	S19-2017G	S19-2018G	S19-2019G
	10	S19-2016H	S19-2017H		
	15	S19-2016J	S19-2017J		
500	2.5	S19-2116D	S19-2117D	S19-2118D	S19-2119D
	5	S19-2116F	S19-2117F	S19-2118F	S19-2119F
	7.5	S19-2116G	S19-2117G	S19-2118G	S19-2119G
	10	S19-2116H	S19-2117H		S19-2119H
	15	S19-2116J	S19-2117J		
600	2.5	S19-2216D	S19-2217D	S19-2218D	S19-2219D
	5	S19-2216F	S19-2217F	S19-2218F	S19-2219F
	7.5	S19-2216G	S19-2217G	S19-2218G	S19-2219G
	10	S19-2216H	S19-2217H		S19-2219H
	15	S19-2216J	S19-2217J		

Primary conductor	30 x 10 mm 20 x 13 mm
Round conductor	Ø 23 mm
Transformer width	95 mm
Snap-on mounting	—
Sealed shutter	<b>Art.-no. 59044</b> see page 207
Current transformer for industrial applications	see page 53
Current transformer for tariff applications	see page 174



# Protection plug-in current transformers

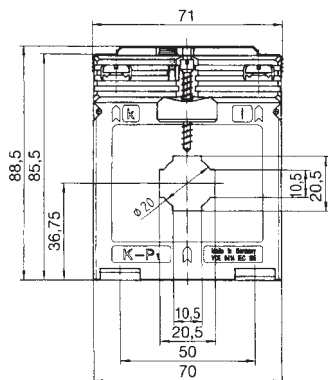
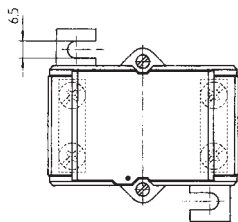
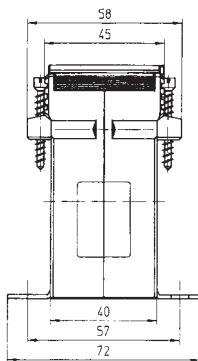
<b>SASK 421.4</b>	Primary conductor Round conductor Transformer width		20 x 10 mm Ø 20 mm 71 mm
<b>SASK 41.4</b>	Primary conductor  Round conductor Transformer width		40 x 10 mm 2 x 30 x 5 mm Ø 32 mm 71 mm
<b>SASK 41.6</b>	Primary conductor  Round conductor Transformer width		40 x 12 mm 30 x 15 mm Ø 32 mm 95 mm
<b>SASK 41.10</b>	Primary conductor Round conductor Transformer width		40 x 10 mm Ø 32 mm 150 mm



# SASK 421.4

Protection plug-in current transformer

Secondary current		5A		1A	
Primary current A	Burden VA	Protection class		Protection class	
		5P5 Art.-no.	10P5 Art.-no.	5P5 Art.-no.	10P5 Art.-no.
200	1.5	S23-1706C	S23-1707C	S23-1716C	S23-1717C
	2.5	S23-1706D	S23-1707D	S23-1716D	S23-1717D
250	1.5	S23-1806C	S23-1807C	S23-1816C	S23-1817C
	2.5	S23-1806D	S23-1807C	S23-1816D	S23-1817C
300	1.5	S23-1906C	S23-1907C	S23-1916C	S23-1917C
	2.5	S23-1906D	S23-1907D	S23-1916D	S23-1917D
400	1.5	S23-2006C	S23-2007C	S23-2016C	S23-2017C
	2.5	S23-2006D	S23-2007D	S23-2016D	S23-2017D



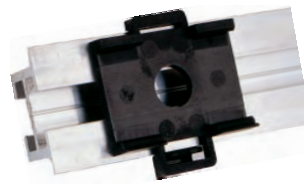
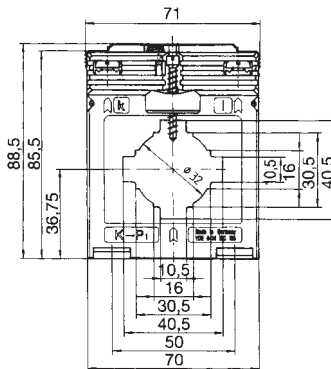
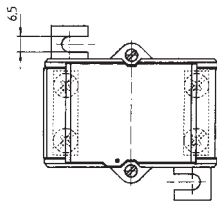
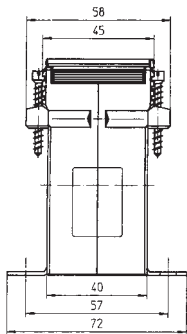
Primary conductor	20 x 10 mm
Round conductor	Ø 20 mm
Transformer width	71 mm
Snap-on mounting	—
Sealed shutter	<b>Art.-no. 59041</b> see page 207
Current transformer for industrial applications	see page 57



# SASK 41.4

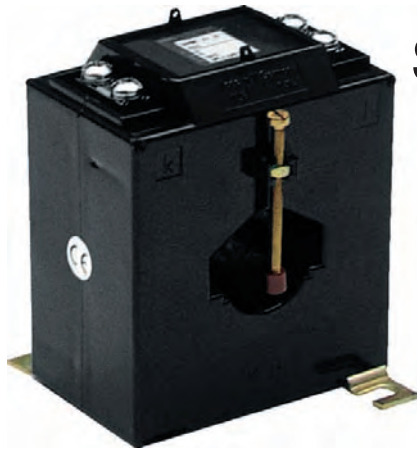
Protection plug-in current transformer

Secondary current		5A		1A	
Primary current A	Burden VA	Protection class		Protection class	
		5P5 Art.-no.	10P5 Art.-no.	5P5 Art.-no.	10P5 Art.-no.
120	1	S24-1406B	S24-1407B	S24-1416B	S24-1417B
125	1	S24-1506B	S24-1507B	S24-1516B	S24-1517B
150	1	S24-1606B	S24-1607B	S24-1616C	S24-1617C
	1.5		S24-1607C		
200	1.5	S24-1706C	S24-1707C	S24-1716C	S24-1717C
250	1.5	S24-1806C	S24-1807C	S24-1816C	S24-1817C
	2.5		S24-1807D		
300	1.5	S24-1906C	S24-1907C	S24-1916C	S24-1917C
	2.5	S24-1906D	S24-1907D	S24-1916D	S24-1917D
400	1.5	S24-2006C	S24-2007C	S24-2016C	S24-2017C
	2.5	S24-2006D	S24-2007D	S24-2016D	S24-2017D
500	1.5	S24-2106C	S24-2107C	S24-2116C	S24-2117C
	2.5			S24-2116D	S24-2117D
600	1.5	S24-2206C	S24-2207C	S24-2216C	S24-2217C
	2.5			S24-2216D	S24-2217D
750	1.5	S24-2306C	S24-2307C	S24-2316C	S24-2317C
	2.5		S24-2307D	S24-2316D	S24-2317D



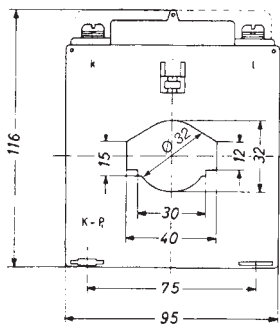
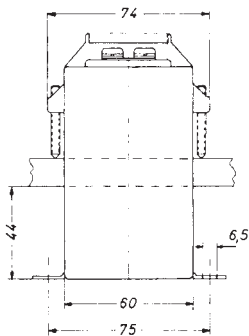
Snap-on mounting

Primary conductor	40 x 10 mm
Round conductor	2 x 30 x 5 mm
Round conductor	Ø 32 mm
Transformer width	71 mm
Snap-on mounting	<b>Art.-no. 55012</b> see page 206
Sealed shutter	<b>Art.-no. 59041</b> see page 207
Current transformer for industrial applications	see page 58
Current transformer for tariff applications	see page 176



# SASK 41.6

Protection plug-in current transformer



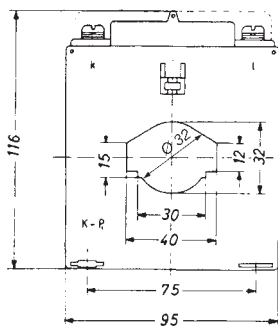
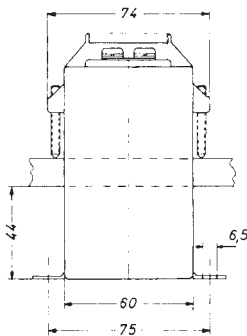
Secondary current		5A			
Primary current A	Burden VA	Protection class			
		5P5 Art.-no.	10P5 Art.-no.	5P10 Art.-no.	10P10 Art.-no.
100	1.5	S30-1306C	S30-1307C	S30-1308C	S30-1309C
	2.5	S30-1306D	S30-1307D		
150	2.5	S30-1606D	S30-1607D	S30-1608D	S30-1609D
	5	S30-1606F	S30-1607F		
200	2.5	S30-1706D	S30-1707D	S30-1708D	S30-1709D
	5	S30-1706F	S30-1707F		
	7.5	S30-1706G	S30-1707G		
	10		S30-1707H		
250	2.5	S30-1806D	S30-1807D	S30-1808D	S30-1809D
	5	S30-1806F	S30-1807F		S30-1809F
	7.5	S30-1806G	S30-1807G		
	10	S30-1806H	S30-1807H		
300	2.5	S30-1906D	S30-1907D	S30-1908D	S30-1909D
	5	S30-1906F	S30-1907F	S30-1908F	S30-1909F
	7.5	S30-1906G	S30-1907G		
	10	S30-1906H	S30-1907H		
400	2.5	S30-2006D	S30-2007D	S30-2008D	S30-2009D
	5	S30-2006F	S30-2007F	S30-2008F	S30-2009F
	7.5	S30-2006G	S30-2007G	S30-2008G	S30-2009G
	10	S30-2006H	S30-2007H		
500	2.5	S30-2106D	S30-2107D	S30-2108D	S30-2109D
	5	S30-2106F	S30-2107F	S30-2108F	S30-2109F
	7.5	S30-2106G	S30-2107G	S30-2108G	S30-2109G
	10	S30-2106H	S30-2107H	S30-2108H	S30-2109H
600	2.5	S30-2206D	S30-2207D	S30-2208D	S30-2209D
	5	S30-2206F	S30-2207F	S30-2208F	S30-2209F
	7.5	S30-2206G	S30-2207G	S30-2208G	S30-2209G
	10	S30-2206H	S30-2207H		

Primary conductor	40 x 12 mm 30 x 15 mm
Round conductor	Ø 32 mm
Transformer width	95 mm
Snap-on mounting	—
Sealed shutter	<b>Art.-no. 59044</b> see page 207
Current transformer for industrial applications	see page 63
Current transformer for tariff applications	see page 178



# SASK 41.6

Protection plug-in current transformer



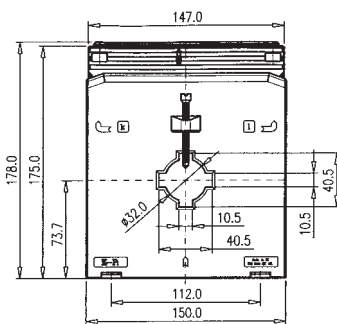
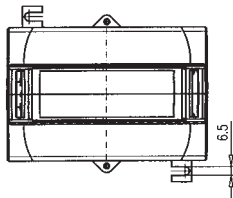
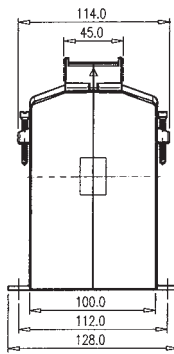
Secondary current		1A			
Primary current A	Burden VA	Protection class			
		5P5 Art.-no.	10P5 Art.-no.	5P10 Art.-no.	10P10 Art.-no.
100	1.5	S30-1316C	S30-1317C	S30-1318C	S30-1319C
	2.5	S30-1316D	S30-1317D		
150	2.5	S30-1616D	S30-1617D	S30-1618D	S30-1619D
	5	S30-1616F	S30-1617F		
	7.5	S30-1616G	S30-1617G		
200	2.5	S30-1716D	S30-1717D	S30-1718D	S30-1719D
	5	S30-1716F	S30-1717F		
	7.5	S30-1716G	S30-1717G		
	10	S30-1716H	S30-1717H		
250	2.5	S30-1816D	S30-1817D	S30-1818D	S30-1819D
	5	S30-1816F	S30-1817F		
	7.5	S30-1816G	S30-1817G		
	10	S30-1816H	S30-1817H		
300	2.5	S30-1916D	S30-1917D	S30-1918D	S30-1919D
	5	S30-1916F	S30-1917F		
	7.5	S30-1916G	S30-1917G		
	10	S30-1916H	S30-1917H		
400	2.5	S30-2016D	S30-2017D	S30-2018D	S30-2019D
	5	S30-2016F	S30-2017F		
	7.5	S30-2016G	S30-2017G		
	10	S30-2016H	S30-2017H		
500	2.5	S30-2116D	S30-2117D	S30-2118D	S30-2119D
	5	S30-2116F	S30-2117F		
	7.5	S30-2116G	S30-2117G		
	10	S30-2116H	S30-2117H		
600	2.5	S30-2216D	S30-2217D	S30-2218D	S30-2219D
	5	S30-2216F	S30-2217F		
	7.5	S30-2216G	S30-2217G		
	10	S30-2216H	S30-2217H		

Primary conductor	40 x 12 mm 30 x 15 mm
Round conductor	Ø 32 mm
Transformer width	95 mm
Snap-on mounting	—
Sealed shutter	<b>Art.-no. 59044</b> see page 207
Current transformer for industrial applications	see page 63
Current transformer for tariff applications	see page 178



# SASK 41.10

Protection plug-in current transformer



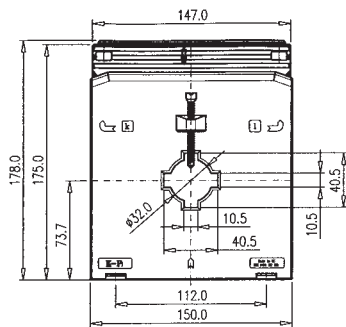
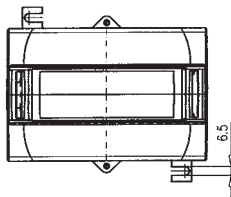
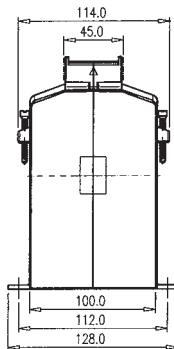
Secondary current		<b>5A</b>			
Primary current A	Burden VA	Protection class			
		5P5	10P5	5P10	10P10
		Art.-no.	Art.-no.	Art.-no.	Art.-no.
100	5	S31-1306F	S31-1307F		S31-1309F
	7.5	S31-1306G	S31-1307G		
	10	S31-1306H	S31-1307H		
	15		S31-1307J		
150	5	S31-1606F	S31-1607F		
	7.5	S31-1606G	S31-1607G		
	10	S31-1606H	S31-1607H		
	15	S31-1606J	S31-1607J		
200	5	S31-1706F	S31-1707F	S31-1708F	S31-1709F
	7.5	S31-1706G	S31-1707G	S31-1708G	S31-1709G
	10	S31-1706H	S31-1707H		S31-1709H
	15	S31-1706J	S31-1707J		
250	5	S31-1806F	S31-1807F	S31-1808F	S31-1809F
	7.5	S31-1806G	S31-1807G	S31-1808G	S31-1809G
	10	S31-1806H	S31-1807H	S31-1808H	S31-1809H
	15	S31-1806J	S31-1807J		S31-1809J
300	5	S31-1906F	S31-1907F	S31-1908F	S31-1909F
	7.5	S31-1906G	S31-1907G	S31-1908G	S31-1909G
	10	S31-1906H	S31-1907H	S31-1908H	S31-1909H
	15	S31-1906J	S31-1907J		S31-1909J
400	5	S31-2006F	S31-2007F	S31-2008F	S31-2009F
	7.5	S31-2006G	S31-2007G	S31-2008G	S31-2009G
	10	S31-2006H	S31-2007H	S31-2008H	S31-2009H
	15	S31-2006J	S31-2007J	S31-2008J	S31-2009J
500	5	S31-2106F	S31-2107F	S31-2108F	S31-2109F
	7.5	S31-2106G	S31-2107G	S31-2108G	S31-2109G
	10	S31-2106H	S31-2107H	S31-2108H	S31-2109H
	15	S31-2106J	S31-2107J	S31-2108J	S31-2109J
600	5	S31-2206F	S31-2207F	S31-2208F	S31-2209F
	7.5	S31-2206G	S31-2207G	S31-2208G	S31-2209G
	10	S31-2206H	S31-2207H	S31-2208H	S31-2209H
	15	S31-2206J	S31-2207J	S31-2208J	S31-2209J
750	5	S31-2306F	S31-2307F	S31-2308F	S31-2309F
	7.5	S31-2306G	S31-2307G	S31-2308G	S31-2309G
	10	S31-2306H	S31-2307H	S31-2308H	S31-2309H
	15	S31-2306J	S31-2307J	S31-2308J	S31-2309J
800	5	S31-2406F	S31-2407F	S31-2408F	S31-2409F
	7.5	S31-2406G	S31-2407G	S31-2408G	S31-2409G
	10	S31-2406H	S31-2407H	S31-2408H	S31-2409H
	15	S31-2406J	S31-2407J	S31-2408J	S31-2409J

Primary conductor	40 x 10 mm
Round conductor	Ø 32 mm
Transformer width	150 mm
Snap-on mounting	—
Sealed shutter	—



# SASK 41.10

Protection plug-in current transformer



Secondary current		<b>1A</b>			
Primary current A	Burden VA	Protection class			
		5P5 Art.-no.	10P5 Art.-no.	5P10 Art.-no.	10P10 Art.-no.
100	5	S31-1316F	S31-1317F		S31-1319F
	7.5	S31-1316G	S31-1317G		
	10	S31-1316H	S31-1317H		
	15		S31-1317J		
150	5	S31-1616F	S31-1617F		S31-1619F
	7.5	S31-1616G	S31-1617G		
	10	S31-1616H	S31-1617H		
	15	S31-1616J	S31-1617J		
200	5	S31-1716F	S31-1717F	S31-1718F	S31-1719F
	7.5	S31-1716G	S31-1717G	S31-1718G	S31-1719G
	10	S31-1716H	S31-1717H		S31-1719H
	15	S31-1716J	S31-1717J		
250	5	S31-1816F	S31-1817F	S31-1818F	S31-1819F
	7.5	S31-1816G	S31-1817G	S31-1818G	S31-1819G
	10	S31-1816H	S31-1817H	S31-1818H	S31-1819H
	15	S31-1816J	S31-1817J		S31-1819J
300	5	S31-1916F	S31-1917F	S31-1918F	S31-1919F
	7.5	S31-1916G	S31-1917G	S31-1918G	S31-1919G
	10	S31-1916H	S31-1917H	S31-1918H	S31-1919H
	15	S31-1916J	S31-1917J		S31-1919J
400	5	S31-2016F	S31-2017F	S31-2018F	S31-2019F
	7.5	S31-2016G	S31-2017G	S31-2018G	S31-2019G
	10	S31-2016H	S31-2017H	S31-2018H	S31-2019H
	15	S31-2016J	S31-2017J	S31-2018J	S31-2019J
500	5	S31-2116F	S31-2117F	S31-2118F	S31-2119F
	7.5	S31-2116G	S31-2117G	S31-2118G	S31-2119G
	10	S31-2116H	S31-2117H	S31-2118H	S31-2119H
	15	S31-2116J	S31-2117J	S31-2118J	S31-2119J
600	5	S31-2216F	S31-2217F	S31-2218F	S31-2219F
	7.5	S31-2216G	S31-2217G	S31-2218G	S31-2219G
	10	S31-2216H	S31-2217H	S31-2218H	S31-2219H
	15	S31-2216J	S31-2217J	S31-2218J	S31-2219J
750	5	S31-2316F	S31-2317F	S31-2318F	S31-2319F
	7.5	S31-2316G	S31-2317G	S31-2318G	S31-2319G
	10	S31-2316H	S31-2317H	S31-2318H	S31-2319H
	15	S31-2316J	S31-2317J	S31-2318J	S31-2319J
800	5	S31-2416F	S31-2417F	S31-2418F	S31-2419F
	7.5	S31-2416G	S31-2417G	S31-2418G	S31-2419G
	10	S31-2416H	S31-2417H	S31-2418H	S31-2419H
	15	S31-2416J	S31-2417J	S31-2418J	S31-2419J

Primary conductor	40 x 10 mm
Round conductor	Ø 32 mm
Transformer width	150 mm
Snap-on mounting	—
Sealed shutter	—



# Protection plug-in current transformers

## SASK 541.4

Primary conductor

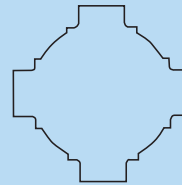
40 x 10 mm

Round conductor  
Transformer width

2 x 30 x 15 mm

Ø 32 mm

86 mm



## SASK 51.4

Primary conductor

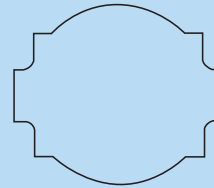
50 x 12 mm

Round conductor  
Transformer width

2 x 40 x 10 mm

Ø 44 mm

86 mm



## SASK 51.6

Primary conductor

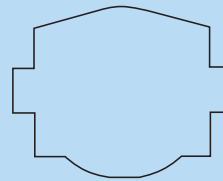
50 x 12 mm

Round conductor  
Transformer width

40 x 30 mm

Ø 40 mm

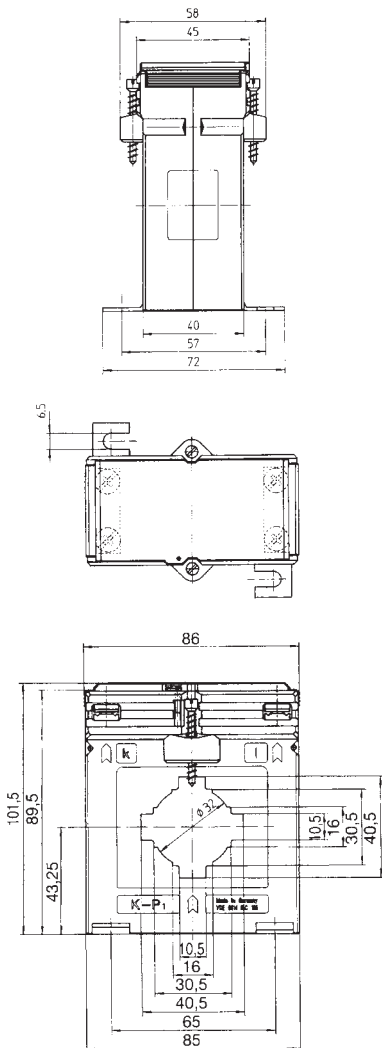
95 mm





# SASK 541.4

Protection plug-in current transformer



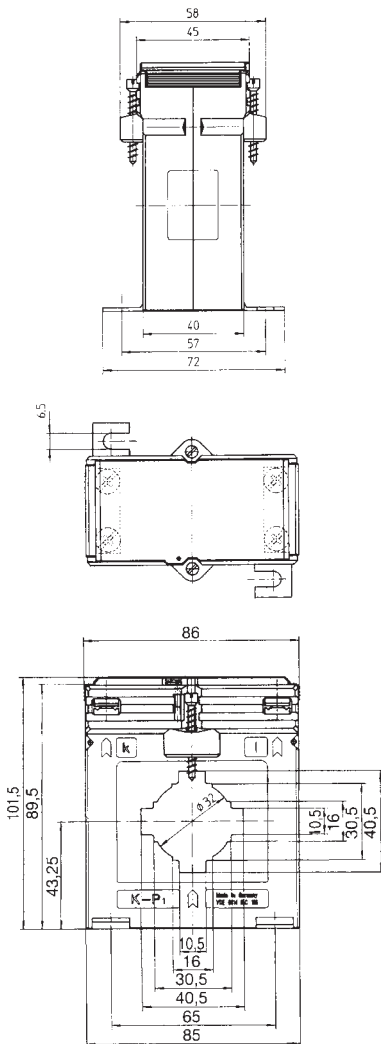
Secondary current		5A			
Primary current A	Burden VA	Protection class			
		5P5 Art.-no.	10P5 Art.-no.	5P10 Art.-no.	10P10 Art.-no.
100	1	S33-1306B	S33-1307B		
	1.5	S33-1306C	S33-1307C		
125	1	S33-1506B	S33-1507B		
	1.5	S33-1506C	S33-1507C		
	2.5		S33-1507D		
150	1.5	S33-1606C	S33-1607C		
	2.5	S33-1606D	S33-1607D		
200	1.5	S33-1706C	S33-1707C		
	2.5	S33-1706D	S33-1707D		
250	1.5	S33-1806C	S33-1807C		S33-1809C
	2.5	S33-1806D	S33-1807D		
300	1.5	S33-1906C	S33-1907C	S33-1908C	S33-1909C
	2.5	S33-1906D	S33-1907D		
	5		S33-1907F		
400	1.5	S33-2006C	S33-2007C	S33-2008C	S33-2009C
	2.5	S33-2006D	S33-2007D		
	5	S33-2006F	S33-2007F		
500	1.5	S33-2106C	S33-2107C	S33-2108C	S33-2109C
	2.5	S33-2106D	S33-2107D	S33-2108D	S33-2109D
	5	S33-2106F	S33-2107F		
	7.5		S33-2107G		
600	1.5	S33-2206C	S33-2207C	S33-2208C	S33-2209C
	2.5	S33-2206D	S33-2207D	S33-2208D	S33-2209D
	5	S33-2206F	S33-2207F		
	7.5		S33-2207G		
750	2.5	S33-2306D	S33-2307D	S33-2308D	S33-2309D
	5	S33-2306F	S33-2307F		
	7.5	S33-2306G	S33-2307G		
1000	2.5	S33-2506D	S33-2507D	S33-2508D	S33-2509D
	5	S33-2506F	S33-2507F		
	7.5	S33-2506G	S33-2507G		
	10	S33-2506H	S33-2507H		

Primary conductor	40 x 10 mm 2 x 30 x 5 mm
Round conductor	Ø 32 mm
Transformer width	86 mm
Snap-on mounting	—
Sealed shutter	<b>Art.-no. 59042</b> see page 207
Current transformer for industrial applications	see page 66
Current transformer for tariff applications	see page 179



# SASK 541.4

Protection plug-in current transformer



Secondary current		<b>1A</b>			
Primary current A	Burden VA	Protection class			
		5P5 Art.-no.	10P5 Art.-no.	5P10 Art.-no.	10P10 Art.-no.
100	1	S33-1316B	S33-1317B		
	1,5	S33-1316C	S33-1317C		
125	1	S33-1516B	S33-1517B		
	1,5	S33-1516C	S33-1517C		
	2,5	S33-1516D	S33-1517D		
150	1,5	S33-1616C	S33-1617C		
	2,5	S33-1616D	S33-1617D		
200	1,5	S33-1716C	S33-1717C		
	2,5	S33-1716D	S33-1717D		
250	1,5	S33-1816C	S33-1817C	S33-1818C	S33-1819C
	2,5	S33-1816D	S33-1817D		
300	1,5	S33-1916C	S33-1917C	S33-1918C	S33-1919C
	2,5	S33-1916D	S33-1917D		
	5		S33-1917F		
400	1,5	S33-2016C	S33-2017C	S33-2018C	S33-2019C
	2,5	S33-2016D	S33-2017D		
	5	S33-2016F	S33-2017F		
500	1,5	S33-2116C	S33-2117C	S33-2118C	S33-2119C
	2,5	S33-2116D	S33-2117D	S33-2118D	S33-2119D
	5	S33-2116F	S33-2117F		
600	1,5	S33-2216C	S33-2217C	S33-2218C	S33-2219C
	2,5	S33-2216D	S33-2217D	S33-2218D	S33-2219D
	5	S33-2216F	S33-2217F		
	7,5		S33-2217G		
750	1,5	S33-2316C	S33-2317C	S33-2318C	S33-2319C
	2,5	S33-2316D	S33-2317D	S33-2318D	S33-2319D
	5	S33-2316F	S33-2317F		
	7,5	S33-2316G	S33-2317G		
1000	2,5	S33-2516D	S33-2517D	S33-2518D	S33-2519D
	5	S33-2516F	S33-2517F		S33-2519F
	7,5	S33-2516G	S33-2517G		
	10	S33-2516H	S33-2517H		

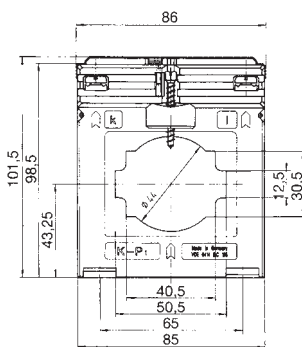
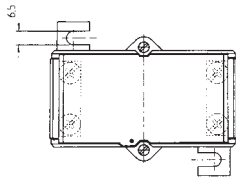
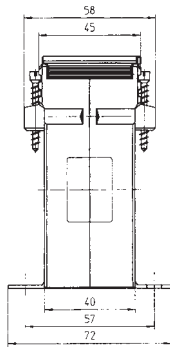
Primary conductor	40 x 10 mm 2 x 30 x 5 mm
Round conductor	Ø 32 mm
Transformer width	86 mm
Snap-on mounting	—
Sealed shutter	<b>Art.-no. 59042</b> see page 207
Current transformer for industrial applications	see page 66
Current transformer for tariff applications	see page 179



# SASK 51.4

Protection plug-in current transformer

Secondary current		5A		1A	
Primary current A	Burden VA	Protection class		Protection class	
		5P5 Art.-no.	10P5 Art.-no.	5P5 Art.-no.	10P5 Art.-no.
150	1			S34-1616B	S34-1617B
200	1	S34-1706B	S34-1707B	S34-1716B	S34-1717B
	1.5		S34-1707C	S34-1716C	S34-1717C
250	1.5	S34-1806C	S34-1807C	S34-1816C	S34-1817C
	2.5				S34-1817D
300	1.5	S34-1906C	S34-1907C	S34-1916C	S34-1917C
	2.5			S34-1916D	S34-1917D
400	1.5	S34-2006C	S34-2007C	S34-2016C	S34-2017C
	2.5		S34-2007D	S34-2016D	S34-2017D
500	1.5	S34-2106C	S34-2107C	S34-2116C	S34-2117C
	2.5		S34-2107D	S34-2116D	S34-2117D
600	1.5	S34-2206C	S34-2207C	S34-2216C	S34-2217C
	2.5		S34-2207D	S34-2216D	S34-2217D
750	1.5	S34-2306C	S34-2307C	S34-2316C	S34-2317C
	2.5	S34-2306D	S34-2307D	S34-2316D	S34-2317D
	5				S34-2317F
1000	1.5	S34-2506C	S34-2507C	S34-2516C	S34-2517C
	2.5	S34-2506D	S34-2507D	S34-2516D	S34-2517D
	5			S34-2516F	S34-2517F



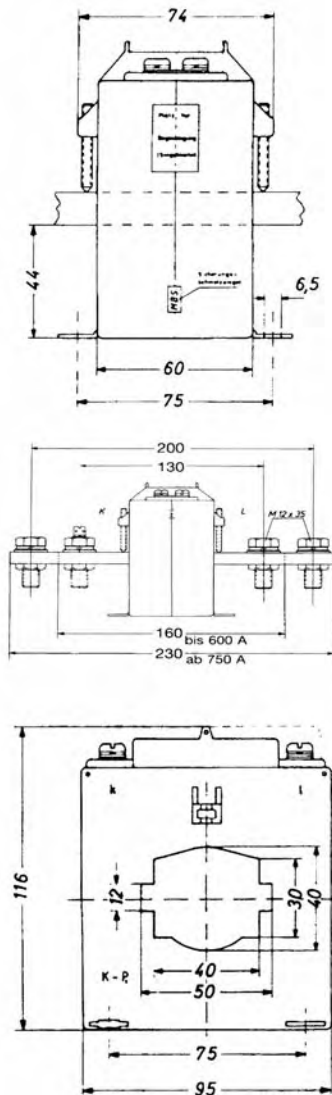
Primary conductor	50 x 12 mm 2 x 40 x 10 mm
Round conductor	Ø 44 mm
Transformer width	86 mm
Snap-on mounting	—
Sealed shutter	<b>Art.-no. 59042</b> see page 207
Current transformer for industrial applications	see page 67
Current transformer for tariff applications	see page 180





# SASK 51.6

Protection plug-in current transformer



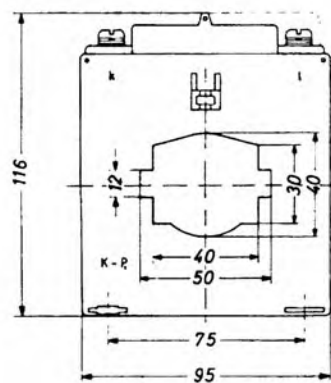
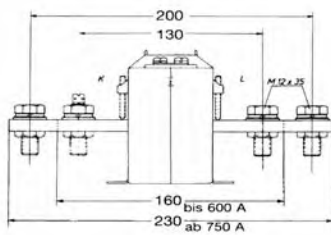
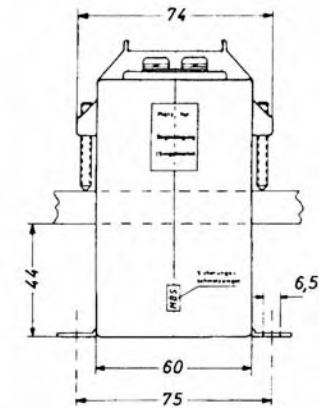
Secondary current		5A			
Primary current A	Burden VA	Protection class			
		5P5 Art.-no.	10P5 Art.-no.	5P10 Art.-no.	10P10 Art.-no.
150	1.5	S37-1606C	S37-1607C	S37-1608C	S37-1609C
	2.5	S37-1606D	S37-1607D		
200	1.5	S37-1706C	S37-1707C	S37-1708C	S37-1709C
	2.5	S37-1706D	S37-1707D		
	5	S37-1706F	S37-1707F		
250	2.5	S37-1806D	S37-1807D	S37-1808D	S37-1809D
	5	S37-1806F	S37-1807F		
	7.5		S37-1807G		
300	2.5	S37-1906D	S37-1907D	S37-1908D	S37-1909D
	5	S37-1906F	S37-1907F		
	7.5	S37-1906G	S37-1907G		
400	2.5	S37-2006D	S37-2007D	S37-2008D	S37-2009D
	5	S37-2006F	S37-2007F		
	7.5	S37-2006G	S37-2007G		
500	2.5	S37-2106D	S37-2107D	S37-2108D	S37-2109D
	5	S37-2106F	S37-2107F		
	7.5	S37-2106G	S37-2107G		
	10	S37-2106H	S37-2107H		
600	2.5	S37-2206D	S37-2207D	S37-2208D	S37-2209D
	5	S37-2206F	S37-2207F		
	7.5	S37-2206G	S37-2207G		
	10	S37-2206H	S37-2207H		
750	2.5	S37-2306D	S37-2307D	S37-2308D	S37-2309D
	5	S37-2306F	S37-2307F	S37-2308F	S37-2309F
	7.5	S37-2306G	S37-2307G		
	10	S37-2306H	S37-2307H		
1000	2.5	S37-2506D	S37-2507D	S37-2508D	S37-2509D
	5	S37-2506F	S37-2507F	S37-2508F	S37-2509F
	7.5	S37-2506G	S37-2507G		
	10	S37-2506H	S37-2507H		

Primary conductor	50 x 12 mm 40 x 30 mm
Round conductor	Ø 40 mm
Transformer width	95 mm
Snap-on mounting	—
Sealed shutter	<b>Art.-no. 59044</b> see page 207
Current transformer for industrial applications	see page 69
Current transformer for tariff applications	see page 181



# SASK 51.6

Protection plug-in current transformer



Secondary current		1A			
Primary current A	Burden VA	Protection class			
		5P5 Art.-no.	10P5 Art.-no.	5P10 Art.-no.	10P10 Art.-no.
150	1.5	S37-1616C	S37-1617C	S37-1618C	S37-1619C
	2.5	S37-1616D	S37-1617D		
200	1.5	S37-1716C	S37-1717C	S37-1718C	S37-1719C
	2.5	S37-1716D	S37-1717D	S37-1718D	S37-1719D
	5	S37-1716F	S37-1717F		
250	2.5	S37-1816D	S37-1817D	S37-1818D	S37-1819D
	5	S37-1816F	S37-1817F		
	7.5		S37-1817G		
300	2.5	S37-1916D	S37-1917D	S37-1918D	S37-1919D
	5	S37-1916F	S37-1917F		
	7.5		S37-1917G		
400	2.5	S37-2016D	S37-2017D	S37-2018D	S37-2019D
	5	S37-2016F	S37-2017F		
	7.5	S37-2016G	S37-2017G		
500	2.5	S37-2116D	S37-2117D	S37-2118D	S37-2119D
	5	S37-2116F	S37-2117F		S37-2119F
	7.5	S37-2116G	S37-2117G		
	10	S37-2116H	S37-2117H		
600	2.5	S37-2216D	S37-2217D	S37-2218D	S37-2219D
	5	S37-2216F	S37-2217F	S37-2218F	S37-2219F
	7.5	S37-2216G	S37-2217G		
	10	S37-2216H	S37-2217H		
750	2.5	S37-2316D	S37-2317D	S37-2318D	S37-2319D
	5	S37-2316F	S37-2317F	S37-2318F	S37-2319F
	7.5	S37-2316G	S37-2317G		
	10	S37-2316H	S37-2317H		
1000	2.5	S37-2516D	S37-2517D	S37-2518D	S37-2519D
	5	S37-2516F	S37-2517F	S37-2518F	S37-2519F
	7.5	S37-2516G	S37-2517G		
	10	S37-2516H	S37-2517H		

Primary conductor	50 x 12 mm 40 x 30 mm
Round conductor	Ø 40 mm
Transformer width	95 mm
Snap-on mounting	—
Sealed shutter	<b>Art.-no. 59044</b> see page 207
Current transformer for industrial applications	see page 69
Current transformer for tariff applications	see page 181



# Protection plug-in current transformers

## SASK 61.4

Primary conductor

60 x 10 mm

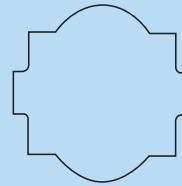
Round conductor

2 x 50 x 10 mm

Transformer width

Ø 44 mm

96 mm



## SASK 61.10

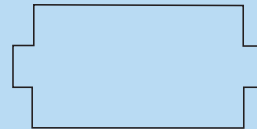
Primary conductor

60 x 10 mm

Transformer width

50 x 30 mm

150 mm



## SASK 63.6

Primary conductor

60 x 30 mm

Round conductor

Ø 30 mm

Transformer width

88 mm



## SASK 105.6

Primary conductor

100 x 55 mm

Round conductor

Ø 55 mm

Transformer width

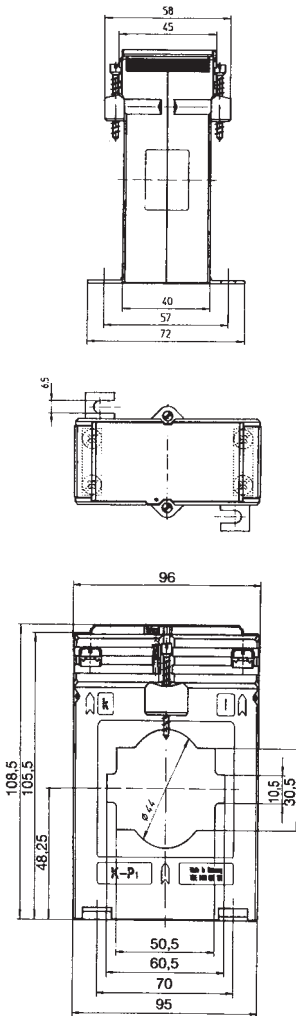
129 mm





# SASK 61.4

Protection plug-in current transformer



Secondary current		5A		1A	
Primary current A	Burden VA	Protection class		Protection class	
		5P5	10P5	5P5	10P5
		Art.-no.	Art.-no.	Art.-no.	Art.-no.
200	1	S41-1706B	S41-1707B	S41-1716B	S41-1717B
	1.5	S41-1706C	S41-1707C	S41-1716C	S41-1717C
250	1	S41-1806B	S41-1807B	S41-1816B	S41-1817B
	1.5	S41-1806C	S41-1807C	S41-1816C	S41-1817C
300	1.5	S41-1906C	S41-1907C	S41-1916C	S41-1917C
	2.5		S41-1907D	S41-1916D	S41-1917D
400	1.5	S41-2006C	S41-2007C	S41-2016C	S41-2017C
	2.5	S41-2006D	S41-2007D	S41-2016D	S41-2017D
500	1.5	S41-2106C	S41-2107C	S41-2116C	S41-2117C
	2.5	S41-2106D	S41-2107D	S41-2116D	S41-2117D
600	1.5	S41-2206C	S41-2207C	S41-2216C	S41-2217C
	2.5	S41-2206D	S41-2207D	S41-2216D	S41-2217D
	5			S41-2216F	S41-2217F
750	1.5	S41-2306C	S41-2307C	S41-2316C	S41-2317C
	2.5	S41-2306D	S41-2307D	S41-2316D	S41-2317D
	5	S41-2307F	S41-2307F	S41-2316F	S41-2317F
1000	1.5	S41-2506C	S41-2507C	S41-2516C	S41-2517C
	2.5	S41-2506D	S41-2507D	S41-2516D	S41-2517D
	5	S41-2506F	S41-2507F	S41-2516F	S41-2517F
1200	1.5	S41-2606C	S41-2607C	S41-2616C	S41-2617C
	2.5	S41-2606D	S41-2607D	S41-2616D	S41-2617D
	5	S41-2606F	S41-2607F	S41-2616F	S41-2617F
1250	1.5	S41-2706C	S41-2707C	S41-2716C	S41-2717C
	2.5	S41-2706D	S41-2707D	S41-2716D	S41-2717D
	5	S41-2706F	S41-2707F	S41-2716F	S41-2717F

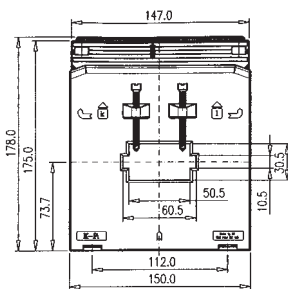
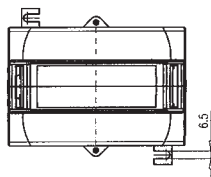
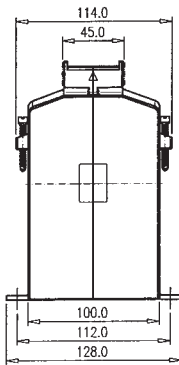
Primary conductor	63 x 10 mm 2 x 50 x 10 mm
Round conductor	Ø 44 mm
Transformer width	96 mm
Snap-on mounting	—
Sealed shutter	<b>Art.-no. 59042</b> see page 207
Current transformer for industrial applications	see page 72
Current transformer for tariff applications	see page 184





# SASK 61.10

Protection plug-in current transformer



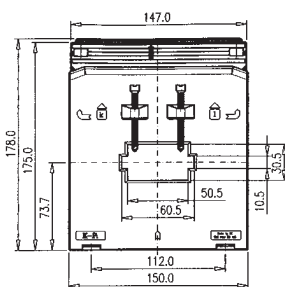
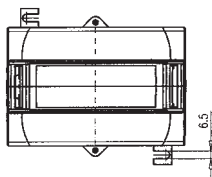
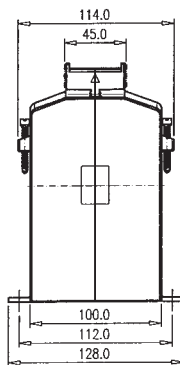
Secondary current		5A			
Primary current A	Burden VA	Protection class			
		5P5	10P5	5P10	10P10
		Art.-no.	Art.-no.	Art.-no.	Art.-no.
250	5	S50-1806F	S50-1807F	S50-1808F	S50-1809F
	7.5	S50-1806G	S50-1807G		S50-1809G
	10	S50-1806H	S50-1807H		
300	5	S50-1906F	S50-1907F	S50-1908F	S50-1909F
	7.5	S50-1906G	S50-1907G	S50-1908G	S50-1909G
	10	S50-1906H	S50-1907H		S50-1909H
	15	S50-1906J	S50-1907J		
400	5	S50-2006F	S50-2007F	S50-2008F	S50-2009F
	7.5	S50-2006G	S50-2007G	S50-2008G	S50-2009G
	10	S50-2006H	S50-2007H	S50-2008H	S50-2009H
	15	S50-2006J	S50-2007J		S50-2009J
500	5	S50-2106F	S50-2107F	S50-2108F	S50-2109F
	7.5	S50-2106G	S50-2107G	S50-2108G	S50-2109G
	10	S50-2106H	S50-2107H	S50-2108H	S50-2109H
	15	S50-2106J	S50-2107J	S50-2108J	S50-2109J
600	5	S50-2206F	S50-2207F	S50-2208F	S50-2209F
	7.5	S50-2206G	S50-2207G	S50-2208G	S50-2209G
	10	S50-2206H	S50-2207H	S50-2208H	S50-2209H
	15	S50-2206J	S50-2207J	S50-2208J	S50-2209J
750	5	S50-2306F	S50-2307F	S50-2308F	S50-2309F
	7.5	S50-2306G	S50-2307G	S50-2308G	S50-2309G
	10	S50-2306H	S50-2307H	S50-2308H	S50-2309H
	15	S50-2306J	S50-2307J	S50-2308J	S50-2309J
1000	5	S50-2506F	S50-2507F	S50-2508F	S50-2509F
	7.5	S50-2506G	S50-2507G	S50-2508G	S50-2509G
	10	S50-2506H	S50-2507H	S50-2508H	S50-2509H
	15	S50-2506J	S50-2507J	S50-2508J	S50-2509J
1200	5	S50-2606F	S50-2607F	S50-2608F	S50-2609F
	7.5	S50-2606G	S50-2607G	S50-2608G	S50-2609G
	10	S50-2606H	S50-2607H	S50-2608H	S50-2609H
	15	S50-2606J	S50-2607J	S50-2608J	S50-2609J
1250	5	S50-2706F	S50-2707F	S50-2708F	S50-2709F
	7.5	S50-2706G	S50-2707G	S50-2708G	S50-2709G
	10	S50-2706H	S50-2707H	S50-2708H	S50-2709H
	15	S50-2706J	S50-2707J	S50-2708J	S50-2709J
1500	5	S50-2806F	S50-2807F	S50-2808F	S50-2809F
	7.5	S50-2806G	S50-2807G	S50-2808G	S50-2809G
	10	S50-2806H	S50-2807H	S50-2808H	S50-2809H
	15	S50-2806J	S50-2807J	S50-2808J	S50-2809J
2000	5	S50-3006F	S50-3007F	S50-3008F	S50-3009F
	7.5	S50-3006G	S50-3007G	S50-3008G	S50-3009G
	10	S50-3006H	S50-3007H	S50-3008H	S50-3009H
	15	S50-3006J	S50-3007J	S50-3008J	S50-3009J

Primary conductor	60 x 10 mm 50 x 30 mm
Round conductor	—
Transformer width	150 mm
Snap-on mounting	—
Sealed shutter	—



# SASK 61.10

Protection plug-in current transformer



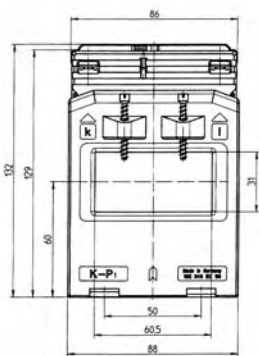
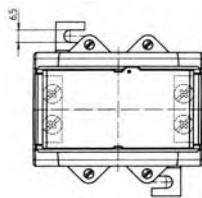
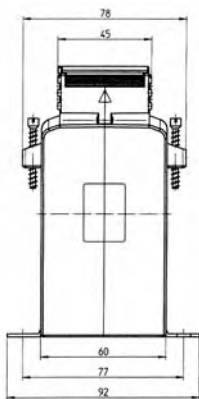
Secondary current		1A			
Primary current A	Burden VA	Protection class			
		5P5	10P5	5P10	10P10
		Art.-no.	Art.-no.	Art.-no.	Art.-no.
250	5	S50-1816F	S50-1817F	S50-1818F	S50-1819F
	7.5	S50-1816G	S50-1817G		S50-1819G
	10	S50-1816H	S50-1817H		
300	5	S50-1916F	S50-1917F	S50-1918F	S50-1919F
	7.5	S50-1916G	S50-1917G		S50-1918G
	10	S50-1916H	S50-1917H		
	15	S50-1916J	S50-1917J		S50-1919H
400	5	S50-2016F	S50-2017F	S50-2018F	S50-2019F
	7.5	S50-2016G	S50-2017G		S50-2018G
	10	S50-2016H	S50-2017H	S50-2018H	S50-2019H
	15	S50-2016J	S50-2017J		S50-2019J
500	5	S50-2116F	S50-2117F	S50-2118F	S50-2119F
	7.5	S50-2116G	S50-2117G		S50-2118G
	10	S50-2116H	S50-2117H	S50-2118H	S50-2119H
	15	S50-2116J	S50-2117J	S50-2118J	S50-2119J
600	5	S50-2216F	S50-2217F	S50-2218F	S50-2219F
	7.5	S50-2216G	S50-2217G		S50-2218G
	10	S50-2216H	S50-2217H	S50-2218H	S50-2219H
	15	S50-2216J	S50-2217J	S50-2218J	S50-2219J
750	5	S50-2316F	S50-2317F	S50-2318F	S50-2319F
	7.5	S50-2316G	S50-2317G		S50-2318G
	10	S50-2316H	S50-2317H	S50-2318H	S50-2319H
	15	S50-2316J	S50-2317J	S50-2318J	S50-2319J
1000	5	S50-2516F	S50-2517F	S50-2518F	S50-2519F
	7.5	S50-2516G	S50-2517G		S50-2518G
	10	S50-2516H	S50-2517H	S50-2518H	S50-2519H
	15	S50-2516J	S50-2517J	S50-2518J	S50-2519J
1200	5	S50-2616F	S50-2617F	S50-2618F	S50-2619F
	7.5	S50-2616G	S50-2617G		S50-2618G
	10	S50-2616H	S50-2617H	S50-2618H	S50-2619H
	15	S50-2616J	S50-2617J	S50-2618J	S50-2619J
1250	5	S50-2716F	S50-2717F	S50-2718F	S50-2719F
	7.5	S50-2716G	S50-2717G		S50-2718G
	10	S50-2716H	S50-2717H	S50-2718H	S50-2719H
	15	S50-2716J	S50-2717J	S50-2718J	S50-2719J
1500	5	S50-2816F	S50-2817F	S50-2818F	S50-2819F
	7.5	S50-2816G	S50-2817G		S50-2818G
	10	S50-2816H	S50-2817H	S50-2818H	S50-2819H
	15	S50-2816J	S50-2817J	S50-2818J	S50-2819J
2000	5	S50-3016F	S50-3017F	S50-3018F	S50-3019F
	7.5	S50-3016G	S50-3017G		S50-3018G
	10	S50-3016H	S50-3017H	S50-3018H	S50-3019H
	15	S50-3016J	S50-3017J	S50-3018J	S50-3019J

Primary conductor	60 x 10 mm 50 x 30 mm
Round conductor	—
Transformer width	150 mm
Snap-on mounting	—
Sealed shutter	—



# SASK 63.6

Protection plug-in current transformer

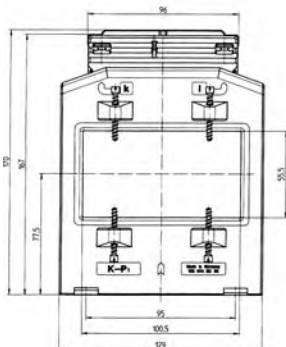
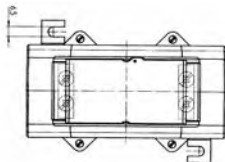
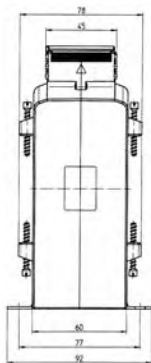


Secondary current		5A		1A	
Primary current A	Burden VA	Protection class		Protection class	
		5P5	10P5	5P5	10P5
		Art.-no.	Art.-no.	Art.-no.	Art.-no.
200	1.5	S46-1706C	S17-1707C	S46-1716C	S46-1717C
	2.5		S46-1707D	S46-1716D	S46-1717D
250	1.5	S46-1806C	S46-1807C	S46-1816C	S46-1817C
	2.5	S46-1806D	S46-1807D	S46-1816D	S46-1817D
300	1.5	S46-1906C	S46-1907C	S46-1916C	S46-1917C
	2.5	S46-1906D	S46-1907D	S46-1916D	S46-1917D
400	2.5	S46-2006D	S46-2007D	S46-2016D	S46-2017D
	5		S46-2007F	S46-2016F	S46-2017F
500	2.5	S46-2106D	S46-2107D	S46-2116D	S46-2117D
	5	S46-2106F	S46-2107F	S46-2116F	S46-2117F
600	2.5	S46-2206D	S46-2207D	S46-2216D	S46-2217D
	5	S46-2206F	S46-2207F	S46-2216F	S46-2217F
750	2.5	S46-2306D	S46-2307D	S46-2316D	S46-2317D
	5	S46-2306F	S46-2307F	S46-2316F	S46-2317F
1000	2.5	S46-2506D	S46-2507D	S46-2516D	S46-2517D
	5	S46-2506F	S46-2507F	S46-2516F	S46-2517F

Primary conductor	60 x 30 mm
Round conductor	Ø 30 mm
Transformer width	88 mm
Snap-on mounting	—
Sealed shutter	<b>Art.-no. 59042</b> see page 207
Current transformer for industrial applications	see page 76
Current transformer for tariff applications	see page 186

# SASK 105.6

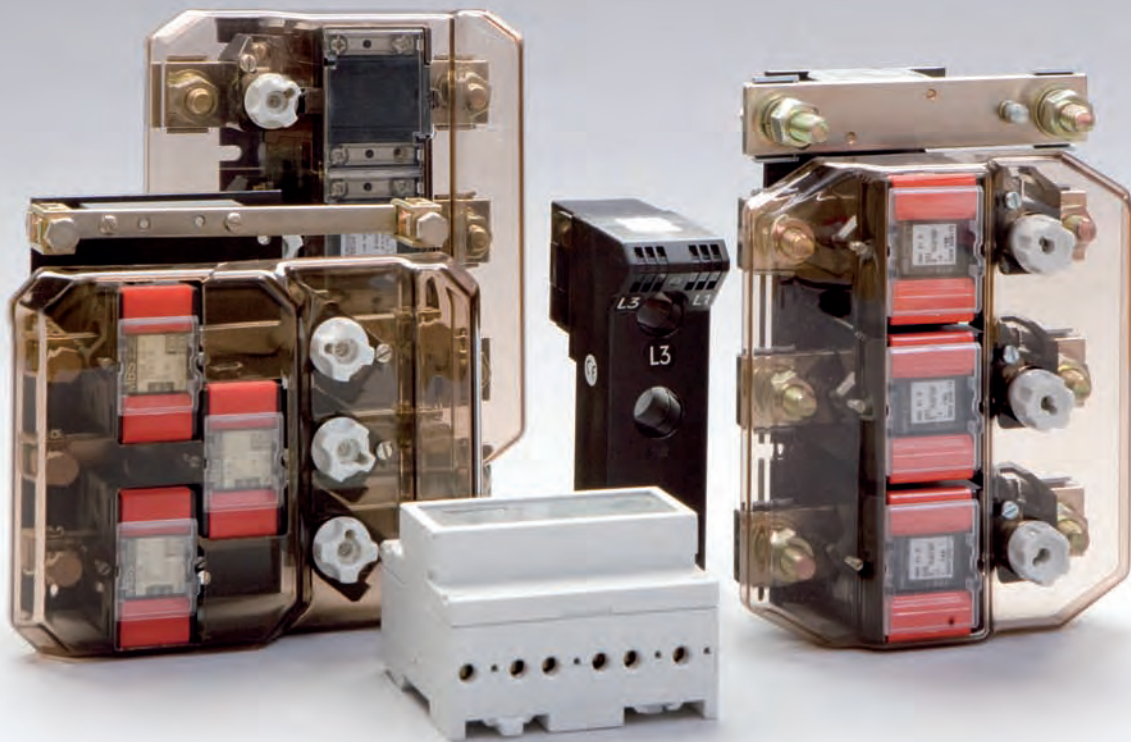
Protection plug-in current transformer



Secondary current		5A		1A	
Primary current A	Burden VA	Protection class		Protection class	
		5P5 Art.-no.	10P5 Art.-no.	5P5 Art.-no.	10P5 Art.-no.
600	2.5	S56-2206C	S56-2207C	S56-2216C	S56-2217C
	5	S56-2206F	S56-2207F	S56-2216F	S56-2217F
750	2.5	S56-2306C	S56-2307C	S56-2316C	S56-2317C
	5	S56-2306F	S56-2307F	S56-2316F	S56-2317F
	10		S56-2307H	S56-2316H	S56-2317H
1000	5	S56-2506F	S56-2507F	S56-2516F	S56-2517F
	10	S56-2506H	S56-2507H	S56-2516H	S56-2517H
	15				S56-2517J
1200	5	S56-2606F	S56-2607F	S56-2616F	S56-2617F
	10	S56-2606H	S26-2607H	S56-2616H	S56-2617H
	15		S26-2607J	S56-2616J	S56-2617J
1250	5	S56-2706F	S56-2707F	S56-2716F	S56-2717F
	10	S56-2706H	S56-2707H	S56-2716H	S56-2717H
	15	S56-2706J	S56-2707J	S56-2716J	S56-2717J
1500	5	S56-2806F	S56-2807F	S56-2816F	S56-2817F
	10	S56-2806H	S56-2807H	S56-2816H	S56-2817H
	15	S56-2806J	S56-2807J	S56-2816J	S56-2817J
1600	10	S56-2906H	S56-2907H	S56-2916H	S56-2917H
	15	S56-2906J	S56-2907J	S56-2916J	S59-2917J

Primary conductor	100 x 55 mm
Round conductor	Ø 55 mm
Transformer width	129 mm
Snap-on mounting	—
Sealed shutter	<b>Art.-no. 59042</b> see page 207
Current transformer for industrial applications	see page 88
Current transformer for tariff applications	see page 190

## Three-phase current transformer sets



[www.mbs-ag.com](http://www.mbs-ag.com)

## Three-phase current transformer sets

<b>ASRD 14</b>	Primary conductor Transformer width	3 x 13.5 mm 105 mm
	for standard rail mounting	

---

<b>ASRD 210.3</b>	Primary conductor Transformer width	3 x 21.5 mm 49.6 mm
	Slim-Line-rail	

---

<b>ASK(D) 21.3</b>	with Plexiglas caps
--------------------	---------------------

---

<b>ASK(D) 31.5</b> <b>ASK(D) 31.5 2u</b>	with Plexiglas caps
---	---------------------

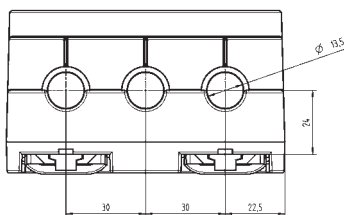
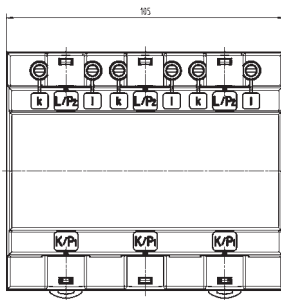
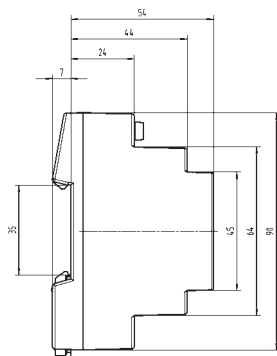
---

<b>WSKD 31.8</b> <b>ASKD 31.8</b>	with Plexiglas caps
--------------------------------------	---------------------

---

# ASRD 14

## Three-phase current transformer set

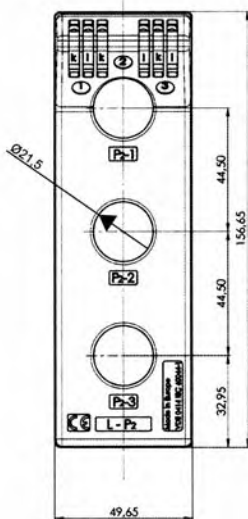
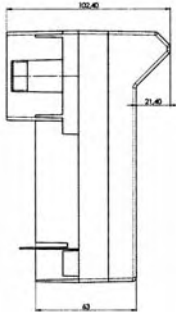
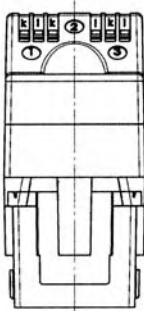


Secondary current		5A		1A	
Primary current A	Burden VA	Accuracy class		Accuracy class	
		1	0.5	1	0.5
		Art.-no.	Art.-no.	Art.-no.	Art.-no.
3 x 50	1	96030		96230	
3 x 60	1.25	96032		96232	
3 x 75	1.5	96034		96234	
3 x 80	1.5	96036		96236	
3 x 100	2.5	96038	96012	96238	96212
3 x 125	2.5	96039	96014		96214
	3.75	96041		96241	
3 x 150	2.5	96040	96017		96217
	3.75	96044		96244	

Primary conductor	—
Round conductor	3 x Ø 13.5 mm
Transformer width	105 mm
Snap-on mounting	integrated
Sealed shutter	—

# ASRD 210.3

## Three-phase current transformer set



Secondary current		5A		1A	
Primary current A	Burden VA	Accuracy class		Accuracy class	
		1	0.5	1	0.5
		Art.-no.	Art.-no.	Art.-no.	Art.-no.
50	1	27700		27800	
60	1	27701		27801	
	1.25	27702		27802	
75	1.25	27703		27803	
	1.5	27704		27804	
80	1.25	27705		27805	
	1.5	27706		27806	
100	1.5	27707	27726	27807	
	2.5	27708	27724	27808	27824
125	1.5	27709		27809	
	2.5	27710		27810	
	3.75	27711		27811	
150	1.5	27712		27812	
	2.5	27713	27725	27813	27825
	3.75	27714		27814	
160	3.75	27750			
200	1.5	27715		27815	
	2.5	27716		27816	
	5	27717		27817	
250	2.5	27718		27818	
	5	27719		27819	
	7.5	27720		27820	
300	2.5	27721		27821	
	5	27722		27822	
	7.5	27723		27823	

Primary conductor	—
Round conductor	3 x Ø 21.5 mm
Transformer width	49.6 mm
Snap-on mounting	—
Sealed shutter	—

## Three-phase current transformer set

### ASK(D) 21.3

with Plexiglas caps

#### Configuration:

The measuring transformer set consists of 3 individual current transformers which are mounted on an aluminium base plate together with the primary conductors L1, L2, L3 and neutral conductor.

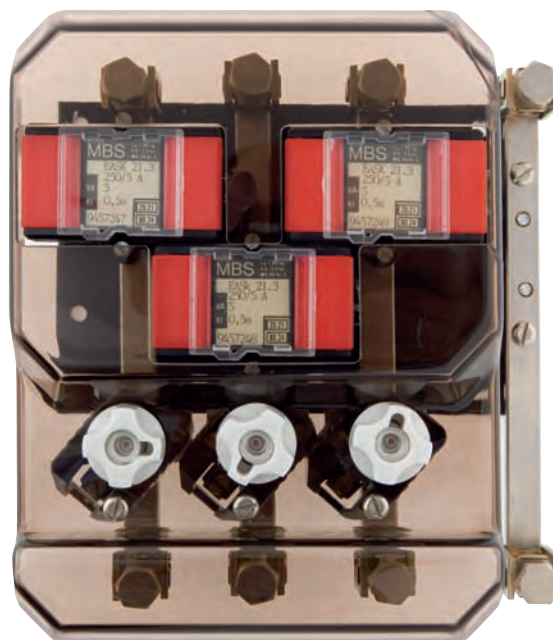
**The current transformer set can be supplied with or without fuses. The voltage supply is optional and can be tapped either from the 10 A-NEOZED fuse or from the individual primary conductors.**

Transparent, sealable covers protect the secondary terminals of the current transformers against external tampering. All voltage carrying parts of the assembled current transformer set are made shock-proof with isolating covers which are included in the deliveries.

Flexible copper wire with a nominal cross section of 16 mm<sup>2</sup> up to 70 mm<sup>2</sup> can be connected to the primary connection terminals.

The configuration of this current transformer set conforms to the technical requirements and guidance:

- DIN EN 60044/1
- DIN 42600
- VBG 4.

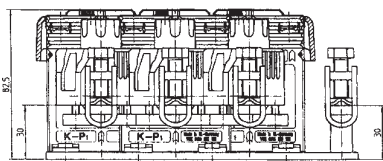
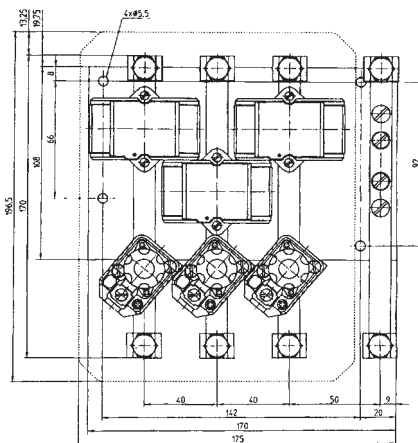


# ASK(D) 21.3

Three-phase current transformer set



Secondary current		5A		1A	
Primary current A	Burden VA	Accuracy class		Accuracy class	
		1	0.5	1	0.5
		Art.-no.	Art.-no.	Art.-no.	Art.-no.
3 x 100	1.5	56027	56011	56227	56211
	2.5	56028	56012	56228	56212
3 x 150	1.5	56029	56013	56229	56213
	2.5	56030	56014	56230	56214
	5	56043	56015	56243	56215
3 x 200	1.5	56031	56016	56231	56216
	2.5	56032	56017	56232	56217
	5	56033	56018	56233	56218



## Three-phase current transformer set

**ASK(D) 31.5**

**ASK(D) 31.5 2u**

with Plexiglas caps

### Configuration:

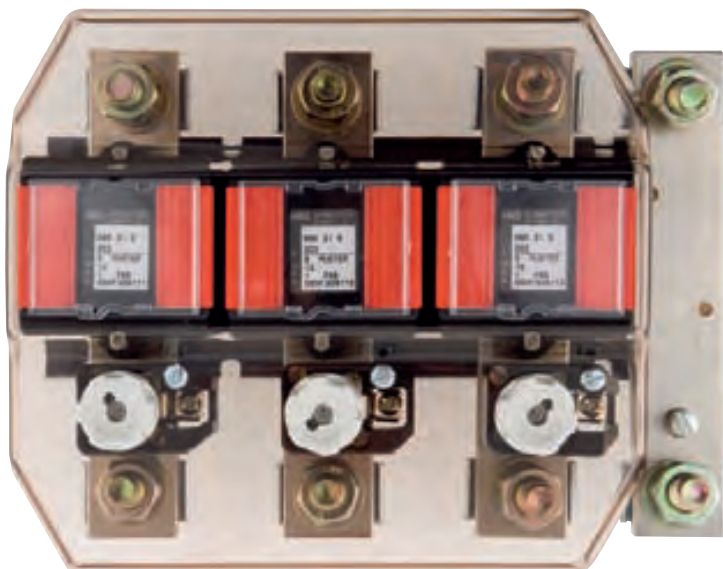
The measuring transformer set consists of 3 individual current transformers which are mounted on an aluminium base plate together with the primary conductors L1, L2, L3. Transparent sealable covers protect the secondary terminals of the current transformers against external tampering.

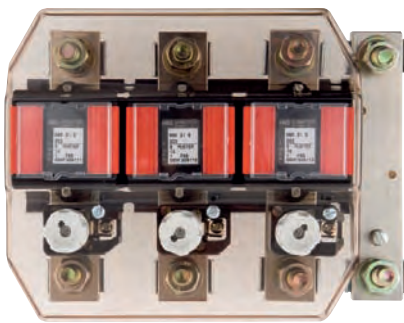
Stipulation of the VBG4 (German protection clause) demands that all voltage carrying parts are made shock-proof with transparent isolating covers which are included in the deliveries.

**As an option the current transformer set can be supplied with or without fuses. The voltage can be tapped either from the 10 A-fuse element or directly from the individual primary conductor.**

The configuration of this current transformer set conforms to:

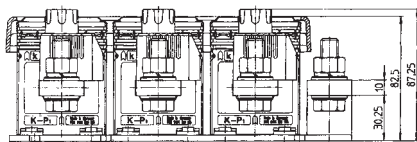
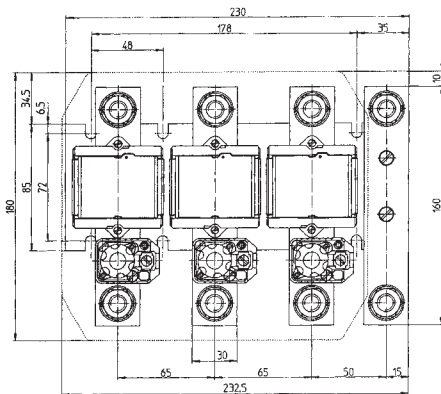
- DIN VDE 0414/1
- DIN 42600 IEC 185
- VBG 4.





# ASK(D) 31.5

Three-phase current transformer set



Secondary current		5A		1A	
Primary current A	Burden VA	Accuracy class		Accuracy class	
		1	0.5	1	0.5
		Art.-no.	Art.-no.	Art.-no.	Art.-no.
3 x 75	2.5	57043	57011	57243	57211
	5	57044	57012	57244	57212
3 x 100	2.5	57045	57013	57245	57213
	5	57046	57014	57246	57214
3 x 150	2.5	57047	57015	57247	57215
	5	57048	57016	57248	57216
3 x 200	2.5	57049	57017	57249	57217
	5	57050	57018	57250	57218
3 x 250	2.5	57051	57019	57251	57219
	5	57052	57020	57252	57220
3 x 300	2.5	57053	57021	57253	57221
	5	57054	57022	57254	57222
3 x 400	2.5	57055	57023	57255	57223
	5	57056	57024	57256	57224
3 x 500	2.5	57057	57025	57257	57225
	5	57058	57026	57258	57226
3 x 600	2.5	57059	57027	57259	57227
	5	57060	57028	57260	57228
3 x 750	2.5	57061	57029	57261	57229
	5	57062	57030	57262	57230
3 x 1000	2.5	57063	57031	57263	57231
	5	57064	57032	57264	57232
3 x 1500	2.5	57065	57033	57265	57233
	5	57066	57034	57266	57234
3 x 2000	2.5	57067	57035	57267	57235
	5	57068	57036	57268	57236
3 x 3000	2.5	57069	57037	57269	57237
	5	57070	57038	57270	57238
3 x 4000	2.5	57071	57039	57271	57239
	5	57072	57040	57272	57240
3 x 5000	2.5	57073	57041	57273	57241
	5	57074	57042	57274	57242

# ASK(D) 31.5 2u

Three-phase secondary change-over current transformer set

Secondary current		5A		1A	
Primary current A	Burden VA	Accuracy class		Accuracy class	
		1	0.5	1	0.5
		Art.-no.	Art.-no.	Art.-no.	Art.-no.
3 x 200-100	5-2.5	57090	57080	57290	57280
	10-5	57091	57081	57291	57281
3 x 300-150	5-2.5	57092	57082	57292	57282
	10-5	57093	57083	57293	57283
3 x 400-200	5-2.5	57094	57084	57294	57284
	10-5	57095	57085	57295	57285
3 x 500-250	5-2.5	57096	57086	57296	57286
	10-5	57097	57087	57297	57287
3 x 600-300	5-2.5	57098	57088	57298	57288
	10-5	57099	57089	57299	57289

## Three-phase current transformer sets

### WSKD 31.8

### ASKD 31.8

with Plexiglas caps

#### Configuration:

The measuring transformer set of the WSKD 31.8 / ASKD 31.8 conform to the following standards:

- DIN EN 60044/1
- DIN 42600
- VBG 4.

Mounted in housing units, are the current transformer sets, consisting of 3 identical individual current transformers, fitted on a metallic base plate made of aluminium with a neutral conductor. The WSKD 31.8 is produced as a wound current transformer with 3 fixed primary windings for primary currents up to 150 A.

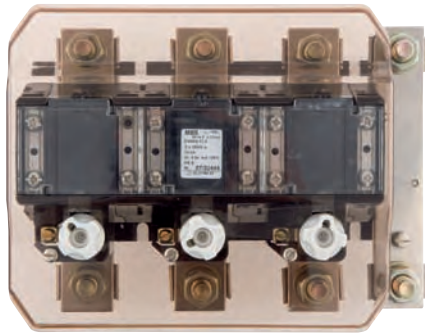
The ASKD 31.8 with primary nominal currents from 200 A are supplied with primary bus bars.

**The current transformer set can be supplied with or without fuses. The voltage supply is optional and can be tapped either from the 10 A-fuse element or directly from the individual primary conductor.**

With 4 mm bore-holes arranged within the secondary connection terminals, a short circuit of the secondary circuit is made possible, when interchanging energy meters. The transformer set can be supplied with or without a base plate (without a base plate there is no neutral conductor rail). All voltage carrying parts of the assembled current transformer sets are made shock-proof with isolating covers which are included in the deliveries.

#### General technical details:

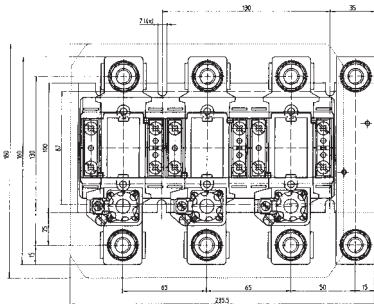
Max. permitted operating voltage:	0.72 kV
Rated frequency:	50 Hz
Over current rated limiting factor:	FS 5
Thermal rated continuous current intensity:	$1.2 \times I_N$
Thermal rated short time current:	$50 \times I_N$ (WSKD 31.8) $60 \times I_N$ (ASKD 31.8)
Isolation class:	E



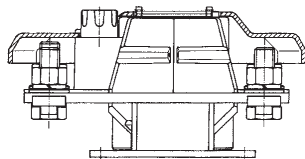
# WSKD 31.8

## Three-phase current transformer set

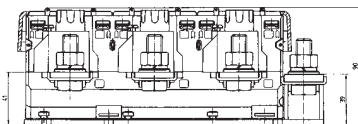
with base plate



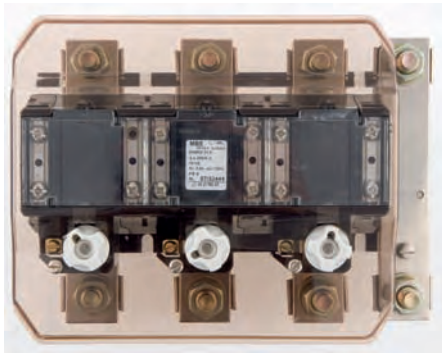
Secondary current		5A		1A	
Primary current A	Burden VA	Accuracy class		Accuracy class	
		1	0.5	1	0.5
		Art.-no.	Art.-no.	Art.-no.	Art.-no.
3 x 50	2.5	44030	44011	44230	44211
	5	44031	44012	44231	44212
	10	44032	44013	44232	44213
3 x 75	2.5	44034	44015	44234	44215
	5	44035	44016	44235	44216
	10	44036	44017	44236	44217
3 x 100	2.5	44038	44019	44238	44219
	5	44039	44020	44239	44220
	10	44040	44021	44240	44221
3 x 150	2.5	44042	44023	44242	44223
	5	44043	44024	44243	44224
	10	44044	44025	44244	44225



without base plate and neutral conductor



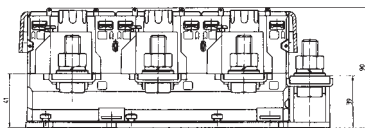
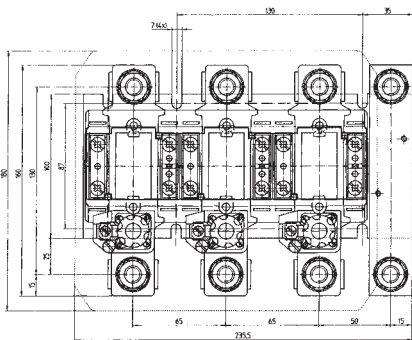
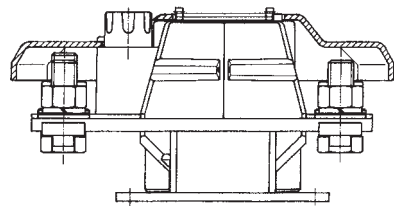
Secondary current		5A		1A	
Primary current A	Burden VA	Accuracy class		Accuracy class	
		1	0.5	1	0.5
		Art.-no.	Art.-no.	Art.-no.	Art.-no.
3 x 50	2.5	45030	45011	45230	45211
	5	45031	45012	45231	45212
	10	45032	45013	45232	45213
3 x 75	2.5	45034	45015	45234	45215
	5	45035	45016	45235	45216
	10	45036	45017	45236	45217
3 x 100	2.5	45038	45019	45238	45219
	5	45039	45020	45239	45220
	10	45040	45021	45240	45221
3 x 150	2.5	45042	45023	45242	45223
	5	45043	45024	45243	45224
	10	45044	45025	45244	45225



# ASKD 31.8

## Three-phase current transformer set

with base plate



Secondary current		5A		1A	
Primary current A	Burden VA	Accuracy class		Accuracy class	
		1	0.5	1	0.5
		Art.-no.	Art.-no.	Art.-no.	Art.-no.
3 x 200	2.5	46041	46011	46241	46211
	5	46042	46012	46242	46212
	10	46043	46013	46243	46213
3 x 250	2.5	46045	46015	46245	46215
	5	46046	46016	46246	46216
	10	46047	46017	46247	46217
3 x 300	2.5	46049	46019	46249	46219
	5	46050	46020	46250	46220
	10	46051	46021	46251	46221
	15	46052	46022	46252	46222
3 x 400	2.5	46053	46023	46253	46223
	5	46054	46024	46254	46224
	10	46055	46025	46255	46225
	15	46056	46026	46256	46226
3 x 500	2.5	46058	46028	46258	46228
	5	46059	46029	46259	46229
	10	46060	46030	46260	46230
	15	46061	46031	46261	46231
3 x 600	2.5	46063	46033	46263	46233
	5	46064	46034	46264	46234
	10	46065	46035	46265	46235
	15	46066	46036	46266	46236

without base plate and neutral conductor

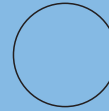
Secondary current		5A		1A	
Primary current A	Burden VA	Accuracy class		Accuracy class	
		1	0.5	1	0.5
		Art.-no.	Art.-no.	Art.-no.	Art.-no.
3 x 200	2.5	47041	47011	47241	47211
	5	47042	47012	47242	47212
	10	47043	47013	47243	47213
3 x 250	2.5	47045	47015	47245	47215
	5	47046	47016	47246	47216
	10	47047	47017	47247	47217
3 x 300	2.5	47049	47019	47249	47219
	5	47050	47020	47250	47220
	10	47051	47021	47251	47221
	15	47052	47022	47252	47222
3 x 400	2.5	47053	47023	47253	47223
	5	47054	47024	47254	47224
	10	47055	47025	47255	47225
	15	47056	47026	47256	47226
3 x 500	2.5	47058	47028	47258	47228
	5	47059	47029	47259	47229
	10	47060	47030	47260	47230
	15	47061	47031	47261	47231
3 x 600	2.5	47063	47033	47263	47233
	5	47064	47034	47264	47234
	10	47065	47035	47265	47235
	15	47066	47036	47266	47236

# Plug-in current transformers for energy measurement

## Tube current transformers

**EASR 14.3**

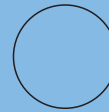
Round conductor  
Transformer width



Ø 14 mm  
61 mm

**EASR 22.3**

Round conductor  
Transformer width

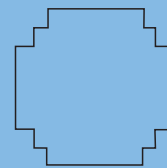


Ø 22.5 mm  
61 mm

## Plug-in current transformers

**EASK 21.3**

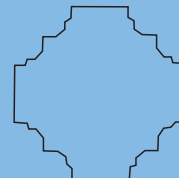
Primary conductor  
Round conductor  
Transformer width



20 x 10 mm  
Ø 19.2 mm  
61 mm

**EASK 31.3**

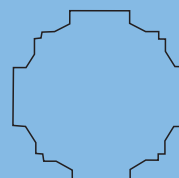
Primary conductor  
Round conductor  
Transformer width



30 x 10 mm  
2 x 20 x 10 mm  
Ø 26 mm  
61 mm

**EASK 31.4**

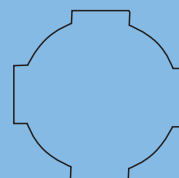
Primary conductor  
Round conductor  
Transformer width



30 x 10 mm  
2 x 20 x 10 mm  
Ø 28 mm  
61 mm

**EASK 31.5**  
**EASK 31.5 2u**

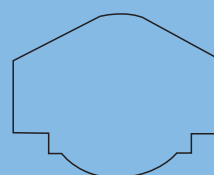
Primary conductor  
Round conductor  
Transformer width



30 x 10 mm  
2 x 20 x 10 mm  
Ø 28 mm  
61 mm

**EASK 31.6**

Primary conductor  
Round conductor  
Transformer width



30 x 10 mm  
20 x 13 mm  
Ø 23 mm  
95 mm

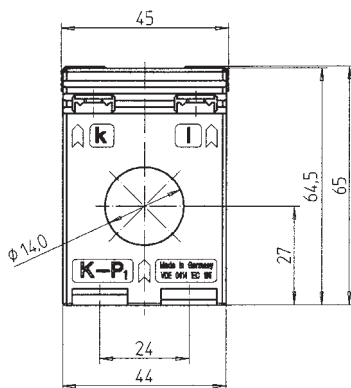
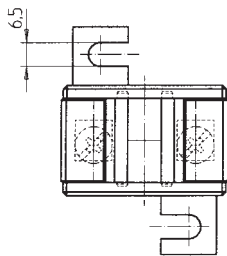
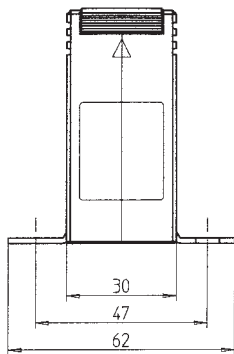
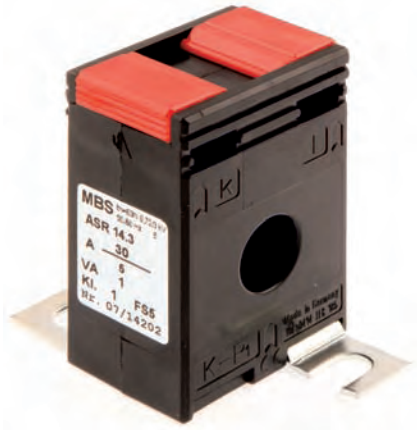
see page 175

Type "E" denotes that the current transformers are for energy measurements.

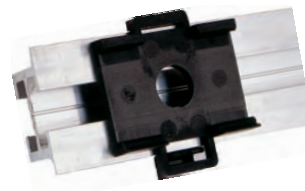
# EASR 14.3

## Tube current transformer

Approved current transformer for tariff applications



Secondary current		5A			1A	
Primary current	Burden	Accuracy class			Accuracy class	
		0.5	0.5s	0.2	0.5	0.2
A	VA	Art.-no.	Art.-no.	Art.-no.	Art.-no.	Art.-no.
75	1.5	26584	26590		26770	
80	1.5	26585	26591		26771	
100	1.5	26586	26592	26561	26786	26777
	2.5	26587	26593	26563	26772	26778
120	1.5	26588	26594		26773	
	2.5	26599	26595	26564	26774	26779
125	1.5	26560	26597	26565	26775	
	2.5	26561	26598	26566	26776	26780
150	1.5	26589	26596	26567	26789	
	2.5					



Snap-on mounting

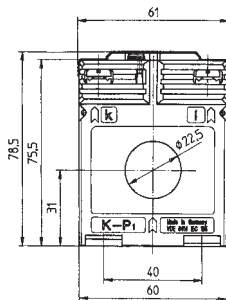
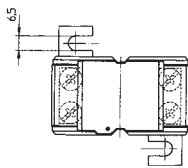
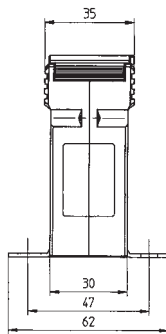
Primary conductor	
Round conductor	Ø 14.0 mm
Transformer width	45 mm
Snap-on mounting	<b>Art.-no. 55013</b> see page 206
Sealed shutter	see page 207
Current transformer for industrial applications	see page 30



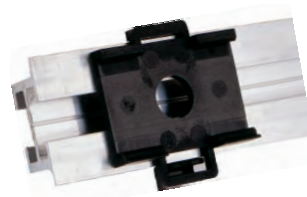
# EASR 22.3

## Tube current transformer

Approved current transformer for tariff applications



Secondary current		5A			1A	
Primary current A	Burden VA	Accuracy class			Accuracy class	
		0.5 Art.-no.	0.5s Art.-no.	0.2 Art.-no.	0.5 Art.-no.	0.2 Art.-no.
100	1.5	3530	3552	3511	3730	3711
	2.5	3531	3553		3731	
150	1.5	3532	3554	3512	3732	3712
	2.5	3533	3555	3513	3733	3713
	5	3534	3556		3734	
200	1.5	3535	3557	3514	3735	3714
	2.5	3536	3558	3515	3736	3715
	5	3537	3559	3516	3737	3716
250	2.5	3538	3560	3517	3738	3717
	5	3539	3561	3518	3739	3718
300	2.5	3540	3562	3519	3740	3719
	5	3541	3563	3520	3741	3720
	10	3542	3564			
400	2.5	3543	3565	3521	3743	3721
	5	3544	3566	3522	3744	3722
	10	3545	3567	3523	3745	3723
500	2.5	3546	3568	3524	3746	3724
	5	3547	3569	3525	3747	3725
	10	3548	3570	3526	3748	3726
600	2.5	3549	3571	3527	3749	3727
	5	3550	3572	3528	3750	3728
	10	3551	3573	3529	3751	3729



Snap-on mounting

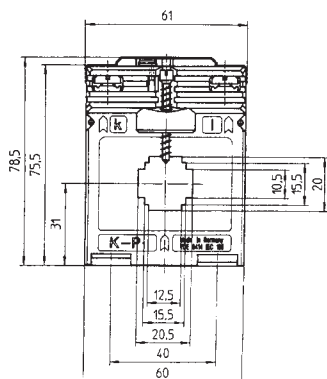
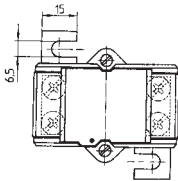
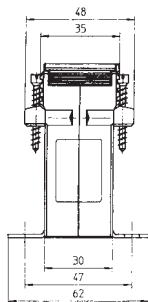
Primary conductor	
Round conductor	Ø 22.5 mm
Transformer width	61 mm
Snap-on mounting	<b>Art.-no. 53011</b> see page 206
Sealed shutter	<b>Art.-no. 59040</b> see page 207
Current transformer for industrial applications	see page 35
Protection plug-in current transformers	see page 127



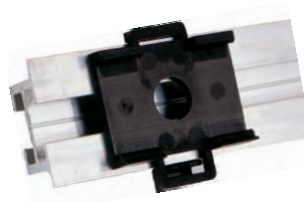
# EASK 21.3

## Plug-in current transformer

Approved current transformer for tariff applications



Secondary current		5A			1A	
Primary current A	Burden VA	Accuracy class			Accuracy class	
		0.5 Art.-no.	0.5s Art.-no.	0.2 Art.-no.	0.5 Art.-no.	0.2 Art.-no.
100	1.5	6530	6549	6511	6730	6711
	2.5	6531	6550		6731	
150	1.5	6532	6551	6513	6732	6713
	2.5	6533	6552	6514	6733	6714
	5	6534	6553		6734	
200	1.5	6535	6554	6516		
	2.5	6536	6555	6517	6736	6717
	5	6537	6556	6518	6737	6718
250	2.5	6538	6557	6519	6738	6719
	5	6539	6558	6520	6739	6720
300	2.5	6540	6559	6521	6740	6721
	5	6541	6560	6522	6741	6722
	10	6542	6561			
400	2.5	6543	6562	6524	6743	6724
	5	6544	6563	6525	6744	6725
	10	6545	6564	6526	6745	6726
500	2.5	6546	6565	6527	6746	6727
	5	6547	6566	6528	6747	6728
	10	6548	6567	6529	6748	6729



Snap-on mounting

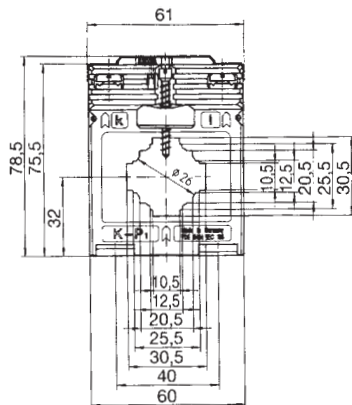
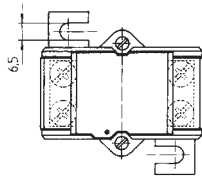
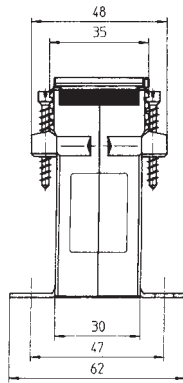
Primary conductor	20 x 10 mm
Round conductor	Ø 19.2 mm
Transformer width	61 mm
Snap-on mounting	<b>Art.-no. 53011</b> see page 206
Sealed shutter	<b>Art.-no. 59040</b> see page 207
Current transformer for industrial applications	see page 45
Protection plug-in current transformers	see page 128



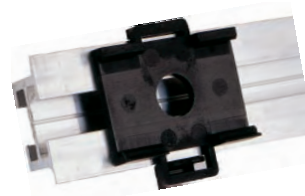
# EASK 31.3

## Plug-in current transformer

Approved current transformer for tariff applications



Secondary current		5A		
Primary current A	Burden VA	Accuracy class		
		0.5 Art.-no.	0.5s Art.-no.	0.2 Art.-no.
100	1.5	7533	7555	7511
	2.5	7534	7556	
150	1.5	7535	7557	7513
	2.5	7536	7558	
200	2.5	7537	7559	7515
	5	7538	7560	7516
250	2.5	7539	7561	7517
	5	7540	7562	7518
300	2.5	7541	7563	7519
	5	7542	7564	7520
400	2.5	7543	7565	7521
	5	7544	7566	7522
500	2.5	7546	7568	7524
	5	7547	7569	7525
600	2.5	7549	7571	7527
	5	7550	7572	7528
750	2.5	7552	7574	7530
	5	7553	7575	7531



Snap-on mounting

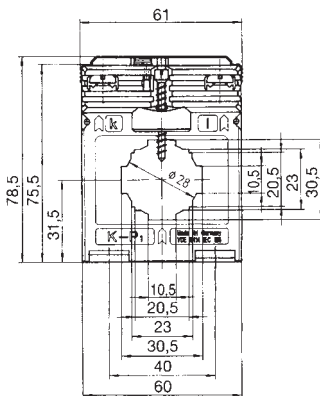
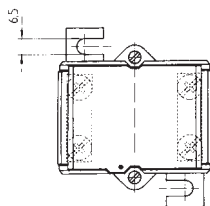
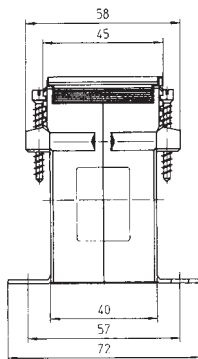
Primary conductor	30 x 10 mm 2 x 20 x 10 mm
Round conductor	Ø 26 mm
Transformer width	61 mm
Snap-on mounting	<b>Art.-no. 53011</b> see page 206
Sealed shutter	<b>Art.-no. 59040</b> see page 207
Current transformer for industrial applications	see page 47



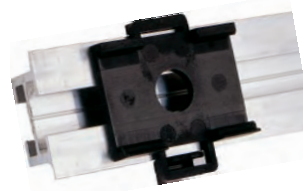
# EASK 31.4

## Plug-in current transformer

Approved current transformer for tariff applications



Secondary current		5A			1A	
Primary current A	Burden VA	Accuracy class			Accuracy class	
		0.5 Art.-no.	0.5s Art.-no.	0.2 Art.-no.	0.5 Art.-no.	0.2 Art.-no.
100	1.5			8510		
	2.5	8535	8559	8511	8735	8711
150	2.5	8536	8560	8512	8736	8712
	5	8537	8561		8737	
200	2.5	8538	8562	8514	8738	8714
	5	8539	8563	8515	8739	8715
250	2.5	8540	8564	8516	8740	8716
	5	8541	8565	8517	8741	8717
300	2.5	8542	8566	8518	8742	8718
	5	8543	8567	8519	8743	8719
	10	8544	8568	8520	8744	8720
400	2.5	8545	8569	8521	8745	8721
	5	8546	8570	8522	8746	8722
	10	8547	8571	8523	8747	8723
500	2.5	8548	8572	8524	8748	8724
	5	8549	8573	8525	8749	8725
	10	8550	8574	8526	8750	8726
600	2.5	8551	8575	8527	8751	8727
	5	8552	8576	8528	8752	8728
	10	8553	8577	8529	8753	8729
	15	8554	8578		8754	
750	2.5	8555	8579	8531	8755	8731
	5	8556	8580	8532	8756	8732
	10	8557	8581	8533	8757	8733
	15	8558	8582		8758	



Snap-on mounting

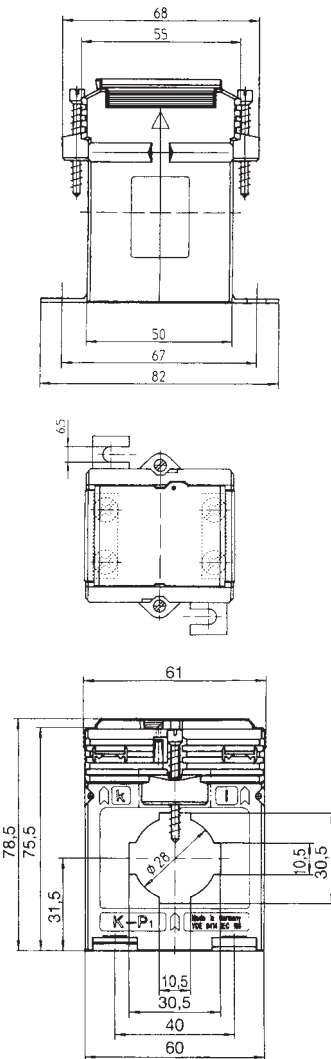
Primary conductor	30 x 10 mm 2 x 20 x 10 mm
Round conductor	Ø 28 mm
Transformer width	61 mm
Snap-on mounting	<b>Art.-no. 54011</b> see page 206
Sealed shutter	<b>Art.-no. 59041</b> see page 207
Current transformer for industrial applications	see page 49



# EASK 31.5

## Plug-in current transformer

Approved current transformer for tariff applications



Secondary current		5A				1A	
Primary current A	Burden VA	Accuracy class				Accuracy class	
		0.5	0.5s	0.2	0.2s	0.5	0.2
		Art.-no.	Art.-no.	Art.-no.	Art.-no.	Art.-no.	Art.-no.
75	2.5	9542	9574			9742	
100	2.5	9543	9575	9511		9743	9711
	5	9544	9576			9744	
150	2.5	9545	9577	9513		9745	9713
	5	9546	9578	9514		9746	9714
200	2.5	9547	9579	9515	V17-1704D	9747	9715
	5	9548	9580	9516	V17-1704F	9748	9716
250	10	9549	9581			9749	
	2.5	9550	9582	9518	V17-1804D	9750	9718
	5	9551	9583	9519	V17-1804F	9751	9719
300	10	9552	9584	9520		9752	9720
	15	9553	9585			9753	
	2.5	9554	9586	9522	V17-1904D	9754	9722
	5	9555	9587	9523	V17-1904F	9755	9723
400	10	9556	9588	9524		9756	9724
	15	9557	9589			9757	
	2.5	9558	9590	9526	V17-2004D	9758	9726
	5	9559	9591	9527	V17-2004F	9759	9727
500	10	9560	9592	9528	V17-2004H	9760	9728
	15	9561	9593			9761	
	2.5	9562	9594	9530	V17-2104D	9762	9730
	5	9563	9595	9531	V17-2104F	9763	9731
600	10	9564	9596	9532	V17-2104H	9764	9732
	15	9565	9597			9765	
	2.5	9566	9598	9534	V17-2204D	9766	9734
	5	9567	9599	9535	V17-2204F	9767	9735
750	10	9568	9600	9536	V17-2204H	9768	9736
	15	9569	9601			9769	
	2.5	9570	9602	9538	V17-2304D	9770	9738
	5	9571	9603	9539	V17-2304F	9771	9739
10	9572	9604	9540	V17-2304H	9772	9740	
	15	9573	9605			9773	

# EASK 31.5 2u

## Secondary change-over current transformer

Primary conductor	30 x 10 mm 2 x 20 x 10 mm
Round conductor	Ø 28 mm
Transformer width	61 mm
Snap-on mounting	<b>Art.-no. 55011</b> see page 206
Sealed shutter	<b>Art.-no. 59041</b> see page 207
Current transformer for industrial applications	see page 51
Protection plug-in current transformers	see page 129

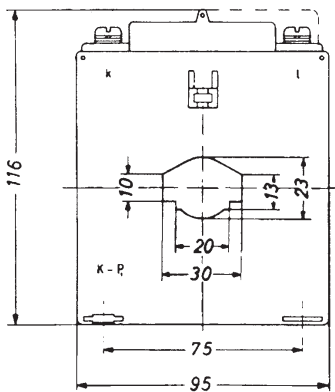
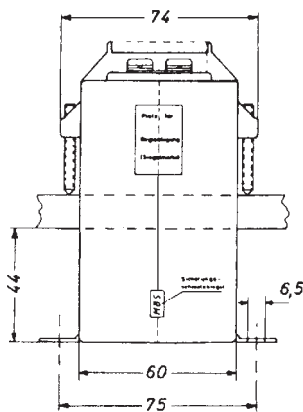
Secondary current		5A	
Primary current A	Burden VA	Accuracy class	
		0.5	0.5s
		Art.-no.	Art.-no.
200-100	5-2.5	9606	9616
	10-5	9607	
300-150	5-2.5	9608	9618
	10-5	9609	9619
400-200	5-2.5	9610	9620
	10-5	9611	9621
500-250	5-2.5	9612	9622
	10-5	9613	9623
600-300	5-2.5	9614	9624
	10-5	9615	9625



# EASK 31.6

## Plug-in current transformer

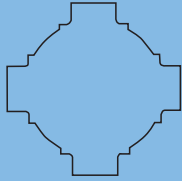
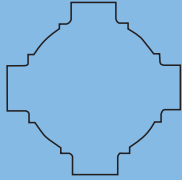
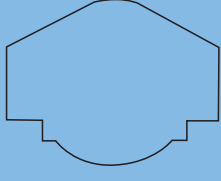
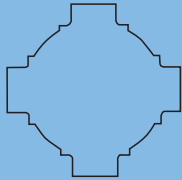
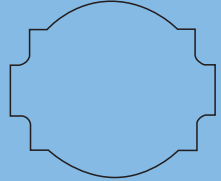
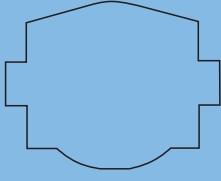
Approved current transformer for tariff applications



Secondary current		5A			1A	
Primary current A	Burden VA	Accuracy class			Accuracy class	
		0.5 Art.-no.	0.5s Art.-no.	0.2 Art.-no.	0.5 Art.-no.	0.2 Art.-no.
50	2.5	10547	10585		10747	
75	2.5	10548	10586		10748	
	5	10549			10749	
100	2.5	10550	10588	10513	10750	10713
	5	10551	10589	10514	10751	
	10	10552	10590		10752	
150	2.5	10553	10591	10516	10753	10716
	5	10554	10592	10517	10754	10717
	10	10555	10593		10755	
	15	10556	10594		10756	
200	5	10557	10595	10521	10757	10721
	10	10558	10596	10522	10758	10722
	15	10559	10597		10759	
250	5	10560	10598	10524	10760	10724
	10	10561	10599	10525	10761	10725
	15	10563	10600		10763	
300	5	10565	10602	10528	10765	10728
	10	10566	10603	10529	10766	10729
	15	10567	10604		10767	
	30	10568	10605		10768	
400	5	10569	10606	10532	10769	10732
	10	10570	10607	10533	10770	10733
	15	10571	10608	10534	10771	10734
	30	10572	10609		10772	
500	5	10573	10610	10536	10773	10736
	10	10574	10611	10537	10774	10737
	15	10575	10612	10538	10775	10738
	30	10576	10613		10776	
600	5	10577	10614	10540	10777	10740
	10	10578	10615	10541	10778	10741
	15	10579	10616	10542	10779	10742
	30	10580	10617		10780	
750	5	10581	10618	10543	10781	10743
	10	10582	10619	10544	10782	10744
	15	10583	10620	10545	10783	10745
	30	10584	10621		10784	

Primary conductor	30 x 10 mm 20 x 13 mm
Round conductor	Ø 23 mm
Transformer width	95 mm
Snap-on mounting	-
Sealed shutter	<b>Art.-no. 59044</b> see page 207
Current transformer for industrial applications	see page 53
Protection plug-in current transformers	see page 130

## Plug-in current transformers for tariff applications

<b>EASK 41.4</b> <b>EASK 41.4 2u</b>	Primary conductor		40 x 10 mm
	Round conductor Transformer width		2 x 30 x 5 mm Ø 32 mm 71 mm
<b>EASK 41.5</b>	Primary conductor		40 x 10 mm
	Round conductor Transformer width		2 x 30 x 5 mm Ø 32 mm 71 mm
<b>EASK 41.6</b>	Primary conductor		40 x 12 mm
	Round conductor Transformer width		30 x 15 mm Ø 32 mm 95 mm
<b>EASK 541.4</b>	Primary conductor		40 x 10 mm
	Round conductor Transformer width		2 x 30 x 5 mm Ø 32 mm 86 mm
<b>EASK 51.4</b> <b>EASK 51.4 2u</b>	Primary conductor		50 x 12 mm
	Round conductor Transformer width		2 x 40 x 10 mm Ø 44 mm 86 mm
<b>EASK 51.6</b>	Primary conductor		50 x 12 mm
	Round conductor Transformer width		40 x 30 mm Ø 40 mm 95 mm

see page 183

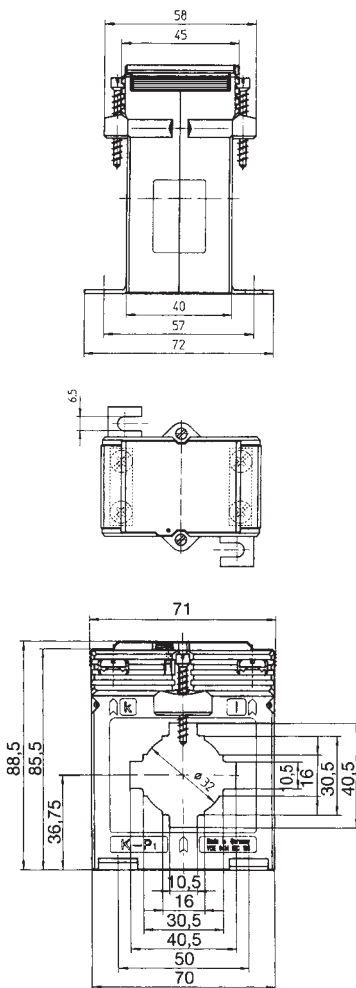
Type "E" denotes that the current transformers are for energy measurements.



# EASK 41.4

## Plug-in current transformer

Approved current transformer for tariff applications



Secondary current		5A			1A	
Primary current A	Burden VA	Accuracy class			Accuracy class	
		0.5 Art.-no.	0.5s Art.-no.	0.2 Art.-no.	0.5 Art.-no.	0.2 Art.-no.
100	1.5	13540	13569	13511	13740	13711
	2.5	13541	13570		13741	
150	1.5	13542	13571	13513	13742	13713
	2.5	13543	13572	13514	13743	13714
	5	13544	13573		13744	
200	1.5	13545	13574	13516	13745	13716
	2.5	13546	13575	13517	13746	13717
	5	13548	13576	13518	13747	13718
250	1.5					13719
	2.5	13549	13578	13520	13749	13720
	5	13550	13579	13521	13750	13721
300	2.5	13551	13580	13522	13751	13722
	5	13552	13581	13523	13752	13723
	10	13553	13582		13753	
400	2.5	13554	13583	13525	13754	13725
	5	13555	13584	13526	13755	13726
	10	13556	13585	13527	13756	13727
500	2.5	13557	13586	13528	13757	13728
	5	13558	13587	13529	13758	13729
	10	13559	13588	13530	13759	13730
	15	13560	13589	13531	13760	13731
600	2.5	13561	13590	13532	13761	13732
	5	13562	13591	13533	13762	13733
	10	13563	13592	13534	13763	13734
	15	13564	13593	13535	13764	13735
750	2.5	13565	13594	13536	13765	13736
	5	13566	13595	13537	13766	13737
	10	13567	13596	13538	13767	13738
	15	13568	13597	13539	13768	

# EASK 41.4 2u

## Plug-in secondary change-over current transformer

Primary conductor	40 x 10 mm 2 x 30 x 5 mm
Round conductor	Ø 32 mm
Transformer width	71 mm
Snap-on mounting	<b>Art.-no. 55012</b> see page 206
Sealed shutter	<b>Art.-no. 59041</b> see page 207
Current transformer for industrial applications	see page 58
Protection plug-in current transformers	see page 135

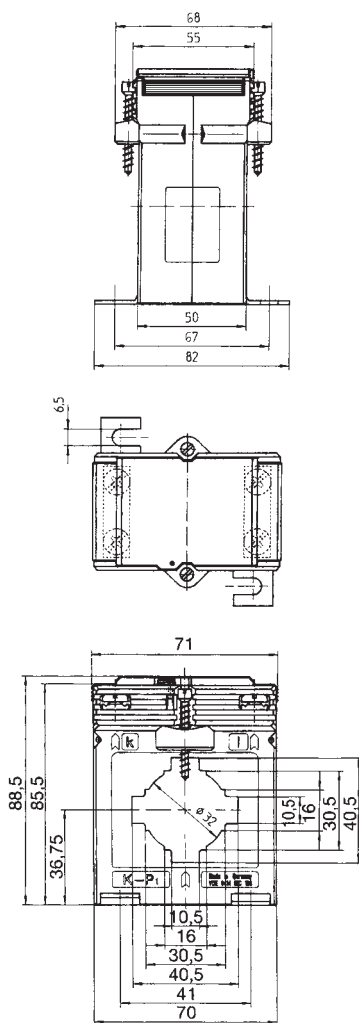
Secondary current		5A	
Primary current A	Burden VA	Accuracy class	
		0.5 Art.-no.	0.5s Art.-no.
200-100	5-2.5	13598	13607
300-150	5-2.5	13599	13608
	10-5	13600	13609
400-200	5-2.5	13601	13610
	10-5	13602	13611
500-250	5-2.5	13603	13612
	10-5	13604	13613
600-300	5-2.5	13605	13614
	10-5	13606	13615



# EASK 41.5

## Plug-in current transformer

Approved current transformer for tariff applications



Secondary current		5A			1A	
Primary current A	Burden VA	Accuracy class			Accuracy class	
		0.5 Art.-no.	0.5s Art.-no.	0.2 Art.-no.	0.5 Art.-no.	0.2 Art.-no.
75	2,5	1010505001			1010705001	
80	2,5	1010505002			1010705002	
100	1,5	1010505003	1010504001	1010503001	1010705003	1010703001
	2,5	1010505004	1010504002		1010705004	1010703002
150	2,5	1010505005	1010504003	1010503002	1010705005	1010703003
	5	1010505006	1010504004		1010705006	1010703004
200	1,5			1010503003		1010703005
	2,5	1010505007	1010504005	1010503033	1010705007	1010703034
	5	1010505008	1010504006	1010503004	1010705008	1010703006
	10				1010705009	
250	2,5	1010505009	1010504007	1010503005	1010705010	1010703007
	5	1010505010	1010504008	1010503006	1010705011	1010703008
	10	1010505011	1010504009	1010503007	1010705012	
300	2,5	1010505012	1010504010	1010503008	1010705013	1010703009
	5	1010505013	1010504011	1010503009	1010705014	1010703010
	10	1010505014	1010504012	1010503010	1010705015	1010703011
	15	1010505015	1010504013		1010705016	
400	2,5	1010505016	1010504014	1010503011	1010705017	1010703012
	5	1010505017	1010504015	1010503012	1010705018	1010703013
	10	1010505018	1010504016	1010503013	1010705019	1010703014
	15	1010505019	1010504017		1010705020	
500	2,5	1010505020	1010504018	1010503014	1010705021	1010703015
	5	1010505021	1010504019	1010503015	1010705022	1010703016
	10	1010505022	1010504020	1010503016	1010705023	1010703017
	15	1010505023	1010504021		1010705024	
600	2,5	1010505024	1010504022	1010503017	1010705025	1010703018
	5	1010505025	1010504023	1010503018	1010705026	1010703019
	10	1010505026	1010504024	1010503019	1010705027	1010703020
	15	1010505027	1010504025	1010503020	1010705028	1010703021
750	2,5	1010505028	1010504026	1010503021	1010705029	1010703022
	5	1010505029	1010504027	1010503022	1010705030	1010703023
	10	1010505030	1010504028	1010503023	1010705031	1010703024
	15	1010505031	1010504029	1010503024	1010705032	1010703025
800	2,5	1010505032	1010504030	1010503025	1010705033	1010703026
	5	1010505033	1010504031	1010503026	1010705034	1010703027
	10	1010505034	1010504032	1010503027	1010705035	1010703028
	15	1010505035	1010504033	1010503028	1010705036	1010703029
1000	2,5	1010505036	1010504034	1010503029	1010705037	1010703030
	5	1010505037	1010504035	1010503030	1010705038	1010703031
	10	1010505038	1010504036	1010503031	1010705039	1010703032
	15	1010505039	1010504037	1010503032	1010705040	1010703033

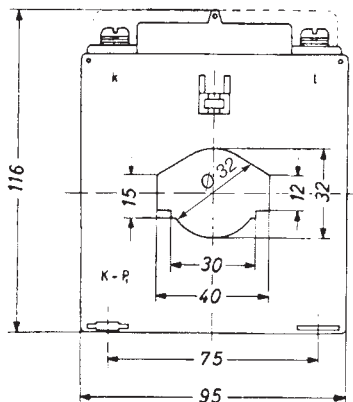
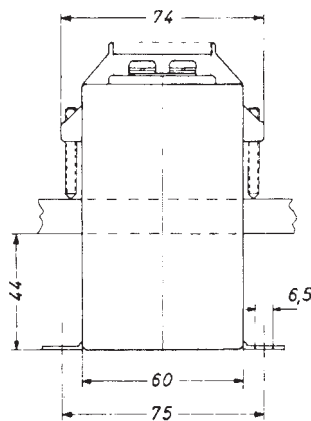
Primary conductor	40 x 10 mm 2 x 30 x 5 mm
Round conductor	Ø 32 mm
Transformer width	71 mm
Snap-on mounting	<b>Art.-no. 55011</b> see page 206
Sealed shutter	<b>Art.-no. 59041</b> see page 207
Current transformer for industrial applications	see page 60



# EASK 41.6

## Plug-in current transformer

Approved current transformer for tariff applications



Secondary current		5A			1A	
Primary current A	Burden VA	Accuracy class			Accuracy class	
		0.5 Art.-no.	0.5s Art.-no.	0.2 Art.-no.	0.5 Art.-no.	0.2 Art.-no.
75	2.5	14552	14595		14752	
	5	14553			14753	
100	2.5	14554	14597	14513	14754	14713
	5	14555	14598		14755	
	10	14556	14599		14756	
150	2.5	14557	14600	14516	14757	14716
	5	14558	14601	14517	14758	14717
	10	14559	14602		14759	
	15	14560	14603		14760	
200	2.5	14561	14604	14520	14761	14720
	5	14562	14605	14521	14762	14721
	10	14563	14606	14522	14763	14722
	15	14564	14607		14764	
250	2.5	14565	14608	14524	14765	14724
	5	14566	14609	14525	14766	14725
	10	14567	14610	14526	14767	14726
	15	14568	14611		14768	
300	2.5	14569	14612	14528	14769	14728
	5	14570	14613	14529	14770	14729
	10	14571	14614	14530	14771	14730
	15	14572	14615	14531	14772	14731
400	2.5	14573	14616	14532	14773	14732
	5	14574	14617	14533	14774	14733
	10	14575	14618	14534	14775	14734
	15	14576	14619	14535	14776	14735
500	2.5	14577	14620	14536	14777	14736
	5	14578	14621	14537	14778	14737
	10	14579	14622	14538	14779	14738
	15	14580	14623	14539	14780	14739
600	2.5	14581	14624	14540	14781	14740
	5	14582	14625	14541	14782	14741
	10	14583	14626	14542	14783	14742
	15	14584	14627	14543	14784	14743
	30	14585	14628			
750	2.5	14586	14629	14544	14786	14744
	5	14587	14630	14545	14787	14745
	10	14588	14631	14546	14788	14746
	15	14589	14632	14547	14789	14747
	30	14590	14633			
1000	5	14591	14634	14548	14791	14748
	10	14592	14635	14549	14792	14749
	15	14593	14636	14550	14793	14750
	30	14594	14637			

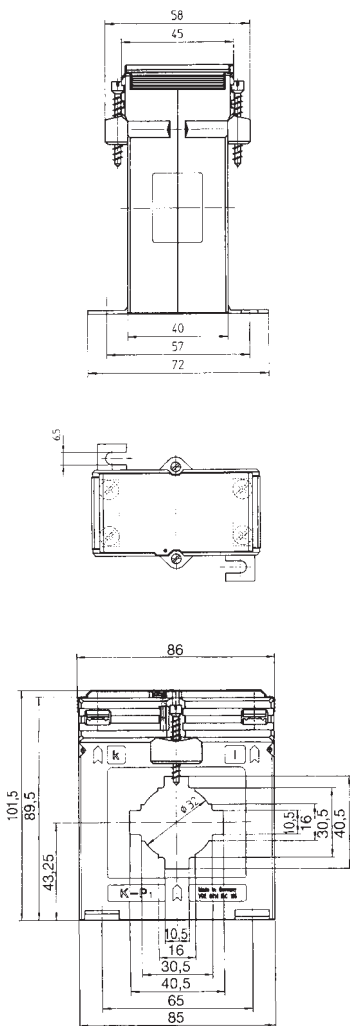
Primary conductor	40 x 12 mm 30 x 15 mm
Round conductor	Ø 32 mm
Transformer width	95 mm
Snap-on mounting	-
Sealed shutter	<b>Art.-no. 59044</b> see page 207
Current transformer for industrial applications	see page 63
Protection plug-in current transformers	see page 136



# EASK 541.4

## Plug-in current transformer

Approved current transformer for tariff applications



Primary conductor	40 x 10 mm 2 x 30 x 5 mm
Round conductor	Ø 32 mm
Transformer width	86 mm
Snap-on mounting	-
Sealed shutter	<b>Art.-no. 59042</b> see page 207
Current transformer for industrial applications	see page 66
Protection plug-in current transformers	see page 142

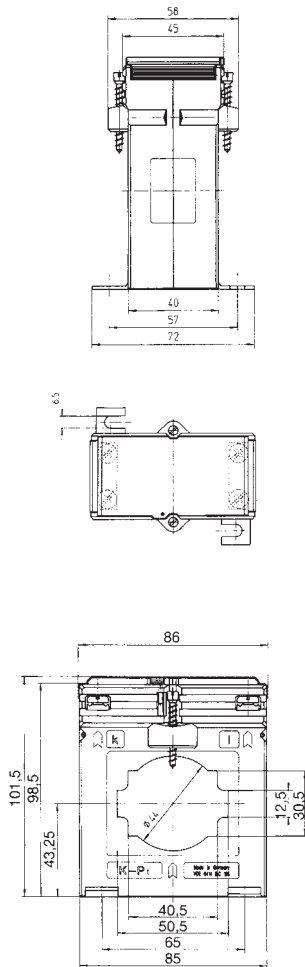
Secondary current		5A			1A	
Primary current A	Burden VA	Accuracy class			Accuracy class	
		0.5 Art.-no.	0.5s Art.-no.	0.2 Art.-no.	0.5 Art.-no.	0.2 Art.-no.
75	1.5	15557	15603		15757	
	2.5	15558	15604		15758	
100	1.5	15559	15605	15513	15759	15713
	2.5	15560	15606	15514	15760	15714
	5	15561	15607		15761	
150	1.5	15562	15608	15516	15762	15716
	2.5	15563	15609	15517	15763	15717
	5	15564	15610	15518	15764	15718
	10	15565	15611		15765	
200	2.5	15566	15612	15520	15766	15720
	5	15567	15613	15521	15767	15721
	10	15568	15614	15522	15768	15722
	15	15569	15615		15769	
250	2.5	15570	15616	15524	15770	15724
	5	15571	15617	15525	15771	15725
	10	15572	15618	15526	15772	15726
	15	15573	15619		15773	
300	2.5	15574	15620	15528	15774	15728
	5	15575	15621	15529	15775	15729
	10	15576	15622	15530	15776	15730
	15	15577	15623	15531	15777	15731
400	2.5	15578	15624	15532	15778	15732
	5	15579	15625	15533	15779	15733
	10	15580	15626	15534	15780	15734
	15	15581	15627	15535	15781	15735
	30	15582	15628			
500	2.5	15583	15629	15537	15783	15737
	5	15584	15630	15538	15784	15738
	10	15585	15631	15539	15785	15739
	15	15586	15632	15540	15786	15740
	30	15587	15633			
600	2.5	15588	15634	15542	15788	15742
	5	15589	15635	15543	15789	15743
	10	15590	15636	15544	15790	15744
	15	15591	15637	15545	15791	15745
	30	15592	15638	15546		
750	2.5	15593	15639	15547	15793	15747
	5	15594	15640	15548	15794	15748
	10	15595	15641	15549	15795	15749
	15	15596	15642	15550	15796	15750
	30	15597	15643	15551		
1000	2.5	15598	15644	15552		
	5	15599	15645	15553	15799	15753
	10	15600	15646	15554	15800	15754
	15	15601	15647	15555	15801	15755
	30	15602	15648	15556		



# EASK 51.4

## Plug-in current transformer

Approved current transformer for tariff applications



Secondary current		5A			1A	
Primary current A	Burden VA	Accuracy class			Accuracy class	
		0.5	0.5s	0.2	0.5	0.2
		Art.-no.	Art.-no.	Art.-no.	Art.-no.	Art.-no.
100	1.5	16542	16573		16742	
	2.5	16543	16574		16743	
150	1.5	16544	16575	16513	16744	16713
	2.5	16545	16576		16745	
200	1.5	16546	16577	16515	16746	16715
	2.5	16547	16578	16516	16747	16716
	5	16548	16579	16517	16748	16717
250	1.5	16549	16580	16518	16749	16718
	2.5	16550	16581	16519	16750	16719
	5	16551	16582	16520	16751	16720
300	2.5	16553	16584	16522	16753	16722
	5	16554	16585	16523	16754	16723
400	2.5	16555	16586	16524	16755	16724
	5	16556	16587	16525	16756	16725
	10	16557	16588	16526	16757	16726
500	2.5	16558	16589	16527	16758	16727
	5	16559	16590	16528	16759	16728
	10	16560	16591	16529	16760	16729
600	2.5	16561	16592	16530	16761	16730
	5	16562	16593	16531	16762	16731
	10	16563	16594	16532	16763	16732
	15	16564	16595	16533	16764	16733
750	2.5	16565	16596	16534		16734
	5	16566	16597	16535	16766	16735
	10	16567	16598	16536	16767	16736
	15	16568	16599	16537	16768	16737
1000	2.5	16569	16600	16538		
	5	16570	16601	16539	16770	16739
	10	16571	16602	16540	16771	16740
	15	16572	16603	16541	16772	16741

# EASK 51.4 2u

## Plug-in secondary change-over current transformer

Primary conductor	50 x 12 mm 2 x 40 x 10 mm
Round conductor	Ø 44 mm
Transformer width	86 mm
Snap-on mounting	-
Sealed shutter	<b>Art.-no. 59042</b> see page 207
Current transformer for industrial applications	see page 67
Protection plug-in current transformers	see page 144

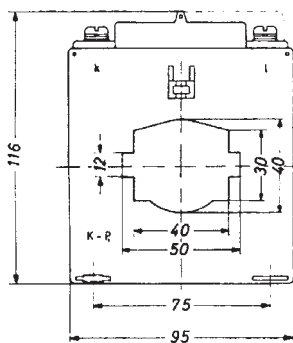
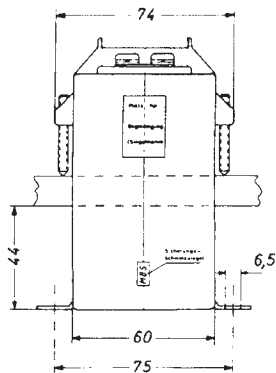
Secondary current		5A	1A
Primary current A	Burden VA	Accuracy class	
		0.5	0.5s
		Art.-no.	Art.-no.
200-100	5-2.5	16611	16621
300-150	5-2.5	16612	16622
400-200	5-2.5	16613	16623
	10-5	16614	16624
500-250	5-2.5	16615	16625
	10-5	16616	16626
600-300	5-2.5	16617	16627
	10-5	16618	16628
1000-500	5-2.5	16619	16629
	10-5	16620	16630



# EASK 51.6

## Plug-in current transformer

Approved current transformer for tariff applications



Primary conductor	50 x 12 mm 40 x 30 mm
Round conductor	Ø 40 mm
Transformer width	95 mm
Snap-on mounting	-
Sealed shutter	<b>Art.-no. 59044</b> see page 207
Current transformer for industrial applications	see page 69
Protection plug-in current transformers	see page 146

Primary current A	Burden VA	5A			1A	
		Accuracy class			Accuracy class	
		0.5	0.5s	0.2	0.5	0.2
		Art.-no.	Art.-no.	Art.-no.	Art.-no.	Art.-no.
100	2.5	17555	17599	17511	17755	17711
	5	17556	17600		17756	
150	2.5	17557	17601	17513	17757	17713
	5	17558	17602	17514	17758	17714
	10	17559	17603		17759	
200	2.5	17560	17604	17516	17760	17716
	5	17561	17605	17517	17761	17717
	10	17562	17606		17762	
250	2.5	17563	17607	17519	17763	17719
	5	17564	17608	17520	17764	17720
	10	17565	17609	17521	17765	17721
	15	17566	17610		17766	
300	2.5	17567	17611	17523	17767	17723
	5	17568	17612	17524	17768	17724
	10	17569	17613	17525	17769	17725
	15	17570	17614		17770	
400	2.5	17571	17615	17527	17771	17727
	5	17572	17616	17528	17772	17728
	10	17573	17617	17529	17773	17729
	15	17574	17618		17774	
500	2.5	17575	17619	17531	17775	17731
	5	17576	17620	17532	17776	17732
	10	17577	17621	17533	17777	17733
	15	17578	17622		17778	
600	2.5	17579	17623	17535	17779	17735
	5	17580	17624	17536	17780	17736
	10	17581	17625	17537	17781	17737
	15	17582	17626	17538	17782	17738
750	2.5	17583	17627	17539	17783	17739
	5	17584	17628	17540	17784	17740
	10	17585	17629	17541	17785	17741
	15	17586	17630	17542	17786	17742
1000	5	17587	17631	17543	17787	17743
	10	17588	17632	17544	17788	17744
	15	17589	17633	17545	17789	17745
	30	17590	17634			
1200	5	17591	17635	17547	17791	17747
	10	17592	17636	17548	17792	17748
	15	17593	17637	17549	17793	17749
	30	17594	17638			
1250	5	17595	17639	17551	17795	17751
	10	17596	17640	17552	17796	17752
	15	17597	17641	17553	17797	17753
	30	17598	17642			



## Plug-in current transformers for tariff applications

### EASK 61.4

Primary conductor

60 x 10 mm

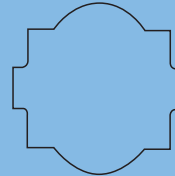
Round conductor

2 x 50 x 10 mm

Transformer width

Ø 44 mm

96 mm



### EASK 61.6

Primary conductor

60 x 10 mm

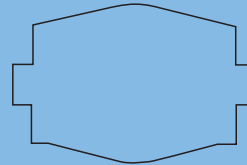
Round conductor

50 x 30 mm

Transformer width

Ø 40 mm

95 mm



### EASK 63.6

Primary conductor

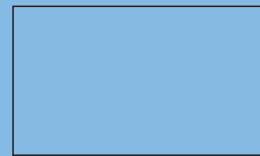
60 x 30 mm

Round conductor

Ø 30 mm

Transformer width

88 mm



### EASK 81.4

Primary conductor

80 x 10 mm

Round conductor

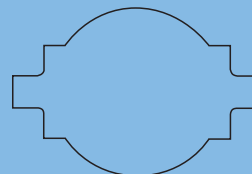
60 x 30 mm

Transformer width

2 x 60 x 10 mm

Ø 55 mm

120 mm



see page 189

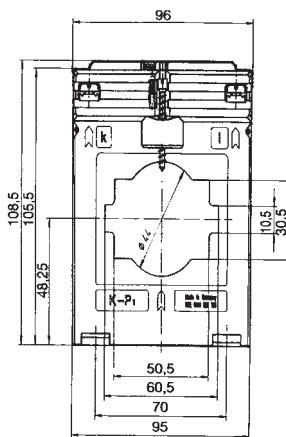
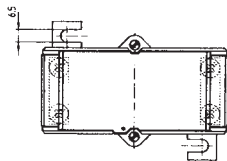
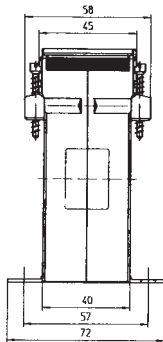
Type "E" denotes that the current transformers are for energy measurements.



# EASK 61.4

## Plug-in current transformer

Approved current transformer for tariff applications



Secondary current		5A			1A	
Primary current A	Burden VA	Accuracy class			Accuracy class	
		0.5 Art.-no.	0.5s Art.-no.	0.2 Art.-no.	0.5 Art.-no.	0.2 Art.-no.
200	1.5	19555	19599	19511	19755	19711
	2.5	19556	19600	19512	19756	19712
250	1.5	19557	19601	19513	19757	19713
	2.5	19558	19602	19514	19758	19714
	5	19559	19603	19515	19759	19715
300	1.5	19560	19604	19516	19760	19716
	2.5	19561	19605	19517	19761	19717
	5	19562	19606	19518	19762	19718
	10	19563	19607		19763	
400	2.5	19564	19608	19520	19764	19720
	5	19565	19609	19521	19765	19721
	10	19566	19610	19522	19766	19722
500	2.5	19567	19611	19523	19767	19723
	5	19568	19612	19524	19768	19724
	10	19569	19613	19525	19769	19725
	15	19570	19614		19770	
600	2.5	19571	19615	19527	19771	19727
	5	19572	19616	19528	19772	19728
	10	19573	19617	19529	19773	19729
	15	19574	19618	19530	19774	19730
750	2.5	19575	19619	19531	19775	19731
	5	19576	19620	19532	19776	19732
	10	19577	19621	19533	19777	19733
	15	19578	19622	19534	19778	19734
1000	2.5	19580	19624	19536		19736
	5	19581	19625	19537	19780	19737
	10	19582	19626	19538	19781	19738
	15	19583	19627	19539	19782	
1200	30	19584	19628			
	2.5	19585	19629	19541		
	5	19586	19630	19542	19785	19741
	10	19587	19631	19543	19786	19742
	15	19588	19632	19544	19787	19743
1250	30	19589				
	5	19590	19634	19546	19790	19746
	10	19591	19635	19547	19791	19747
	15	19592	19636	19548	19792	19748
1500	30	19593	19637			
	5	19595	19639	19551	19795	19751
	10	19596	19640	19552	19796	19752
	15	19597	19641	19553	19797	19753
	30	19598	19642			

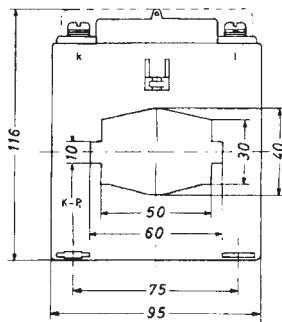
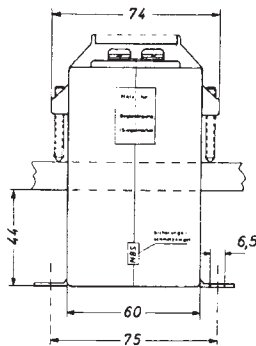
Primary conductor	60 x 10 mm 2 x 50 x 10 mm
Round conductor	Ø 44 mm
Transformer width	96 mm
Snap-on mounting	-
Sealed shutter	<b>Art.-no. 59042</b> see page 207
Current transformer for industrial applications	see page 72
Protection plug-in current transformers	see page 150



# EASK 61.6

## Plug-in current transformer

Approved current transformer for tariff applications



Secondary current		5A			1A	
Primary current A	Burden VA	Accuracy class			Accuracy class	
		0.5 Art.-no.	0.5s Art.-no.	0.2 Art.-no.	0.5 Art.-no.	0.2 Art.-no.
200	2.5	20552	20593	20511	20752	20711
	5	20553	20594		20753	
250	2.5	20554	20595	20513	20754	20713
	5	20555	20596	20514	20755	20714
	10	20556	20597		20756	
300	2.5	20557	20598	20516	20757	20716
	5	20558	20599	20517	20758	20717
	10	20559	20600	20518	20759	20718
	15	20560	20601		20760	
400	2.5	20561	20602	20520	20761	20720
	5	20562	20603	20521	20762	20721
	10	20563	20604	20522	20763	20722
	15	20564	20605		20764	
500	2.5	20565	20606	20524	20765	20724
	5	20566	20607	20525	20766	20725
	10	20567	20608	20526	20767	20726
	15	20568	20609		20768	
600	2.5	20569	20610	20528	20769	20728
	5	20570	20611	20529	20770	20729
	10	20571	20612	20530	20771	20730
	15	20572	20613		20772	
750	2.5	20573	20614	20532	20773	20732
	5	20574	20615	20533	20774	20733
	10	20575	20616	20534	20775	20734
	15	20576	20617	20535	20776	20735
1000	5	20577	20618	20536	20777	20736
	10	20578	20619	20537	20778	20737
	15	20579	20620	20538	20779	20738
	30	20580	20621			
1200	5	20581	20622	20540	20781	20740
	10	20582	20623	20541	20782	20741
	15	20583	20624	20542	20783	20742
	30	20584	20625			
1250	5	20585	20626	20544	20785	20744
	10	20586	20627	20545	20786	20745
	15	20587	20628	20546	20787	20746
	30	20588	20629			
1500	5	20589	20630	20548	20789	20748
	10	20590	20631	20549	20790	20749
	15	20591	20632	20550	20791	20750
	30	20592	20633			

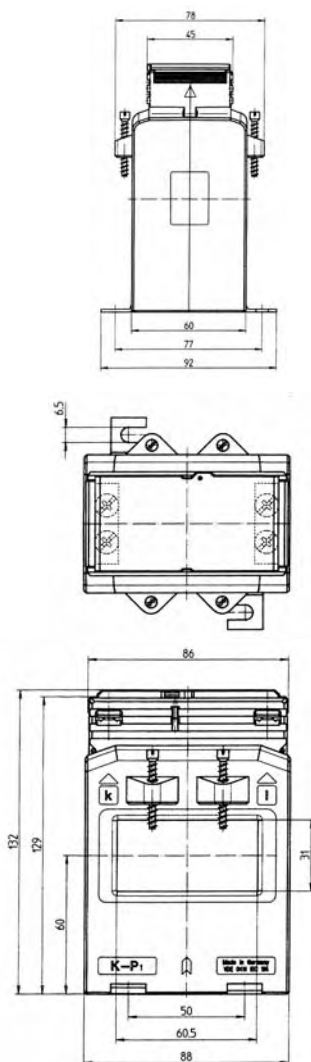
Primary conductor	60 x 10 mm 50 x 30 mm
Round conductor	Ø 40 mm
Transformer width	95 mm
Snap-on mounting	-
Sealed shutter	<b>Art.-no. 59044</b> see page 207
Current transformer for industrial applications	see page 74



# EASK 63.6

## Plug-in current transformer

Approved current transformer for tariff applications



Secondary current		5A			1A	
Primary current A	Burden VA	Accuracy class			Accuracy class	
		0.5	0.5s	0.2	0.5	0.2
		Art.-no.	Art.-no.	Art.-no.	Art.-no.	Art.-no.
250	2.5	85558	85602	85513	85758	85713
	5	85559	85603		85759	
300	2.5	85560	85604	85515	85760	85715
	5	85561	85605	85516	85761	85716
	10	85562	85606		85762	
400	2.5	85563	85607	85518	85763	85718
	5	85564	85608	85519	85764	85719
	10	85565	85609		85765	85720
500	2.5	85566	85610	85521	85766	85721
	5	85567	85611	85522	85767	85722
	10	85568	85612	85523	85768	85723
	15	85569	85613		85769	
600	2.5	85570	85614	85525	85770	85725
	5	85571	85615	85526	85771	85726
	10	85572	85616	85527	85772	85727
	15	85573	85617	85528	85773	85728
750	5	85574	85618	85530	85774	85730
	10	85575	85619	85531	85775	85731
	15	85576	85620	85532	85776	85732
	30	85577	85621		85777	
1000	5	85578	85622	85534	85778	85734
	10	85579	85623	85535	85779	85735
	15	85580	85624	85536	85780	85736
	30	85581	85625		85781	
1200	5	85582	85626	85538	85782	85738
	10	85583	85627	85539	85783	85739
	15	85584	85628	85540	85784	85740
	30	85585	85629		85785	
1250	5	85586	85630	85542	85786	85742
	10	85587	85631	85543	85787	85743
	15	85588	85632	85544	85788	85744
	30	85589	85633		85789	
1500	5	85590	85634	85546	85790	85746
	10	85591	85635	85547	85791	85747
	15	85592	85636	85548	85792	85748
	30	85593	85637		85793	

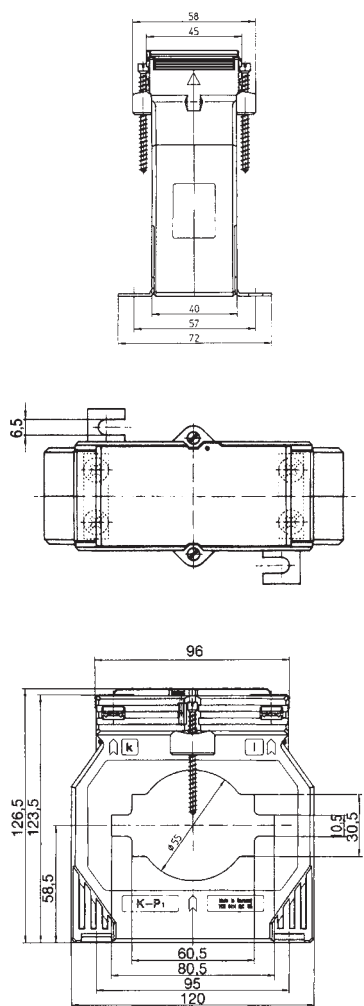
Primary conductor	60 x 30 mm
Round conductor	Ø 30 mm
Transformer width	88 mm
Snap-on mounting	-
Sealed shutter	<b>Art.-no. 59042</b> see page 207
Current transformer for industrial applications	see page 76
Protection plug-in current transformers	see page 154



# EASK 81.4

## Plug-in current transformer

Approved current transformer for tariff applications



Secondary current		5A			1A	
Primary current A	Burden VA	Accuracy class			Accuracy class	
		0.5	0.5s	0.2	0.5	0.2
		Art.-no.	Art.-no.	Art.-no.	Art.-no.	Art.-no.
400	2.5	21541	21571	21511	21741	21711
	5	21542	21572	21512	21742	21712
	10	21543	21573		21743	
500	2.5	21544	21574	21514	21744	21714
	5	21545	21575	21515	21745	21715
	10	21546	21576	21516	21746	21716
600	2.5	21547	21577	21517	21747	21717
	5	21548	21578	21518	21748	21718
	10	21549	21579	21519	21749	21719
	15	21550	21580	21520		
750	2.5	21551	21581	21521	21751	21721
	5	21552	21582	21522	21752	21722
	10	21553	21583	21523	21753	21723
	15	21554	21584	21524		
1000	2.5	21555	21585	21525		
	5	21556	21586	21526	21756	21726
	10	21557	21587	21527	21757	21727
	15	21558	21588	21528	21758	
1200	5	21560	21590	21530	21760	21730
	10	21561	21591	21531	21761	21731
	15	21562	21592	21532	21762	
1250	5	21564	21594	21534	21764	21734
	10	21565	21595	21535	21765	21735
	15	21566	21596	21536	21766	21736
1500	2.5	21567		21537		
	5	21568	21598	21538	21768	21738
	10	21569	21599	21539	21769	21739
	15	21570	21600	21540	21770	21740

Primary conductor	80 x 10 mm 60 x 30 mm 2 x 60 x 10 mm
Round conductor	Ø 55 mm
Transformer width	120 mm
Snap-on mounting	-
Sealed shutter	<b>Art.-no. 59042</b> see page 207
Current transformer for industrial applications	see page 77



## Plug-in current transformers for tariff applications

### EASK 105.6

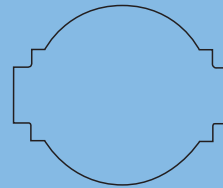
Primary conductor  
Round conductor  
Transformer width



100 x 55 mm  
Ø 55 mm  
129 mm

### EASK 123.3

Primary conductor  
Round conductor  
Transformer width



123 x 30 mm  
3 x 100 x 10 mm  
Ø 100 mm  
172 mm

### EASK 130.3

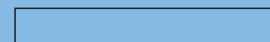
Primary conductor  
Transformer width



130 x 25 mm  
180 mm

### EASK 130.5

Primary conductor  
Transformer width



130 x 30 mm  
180 mm

see page 195

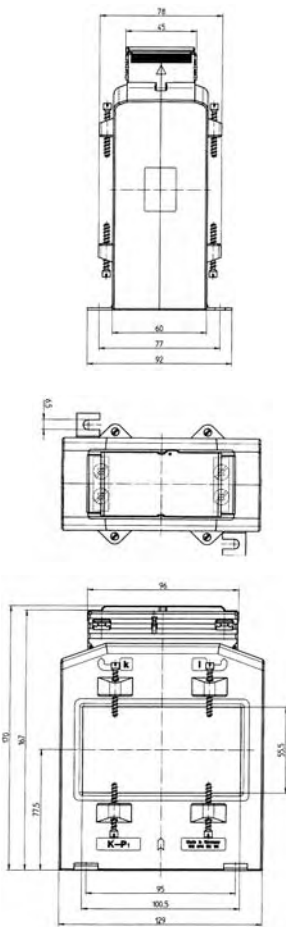
Type "E" denotes that the current transformers are for energy measurements.



# EASK 105.6

## Plug-in current transformer

Approved current transformer for tariff applications



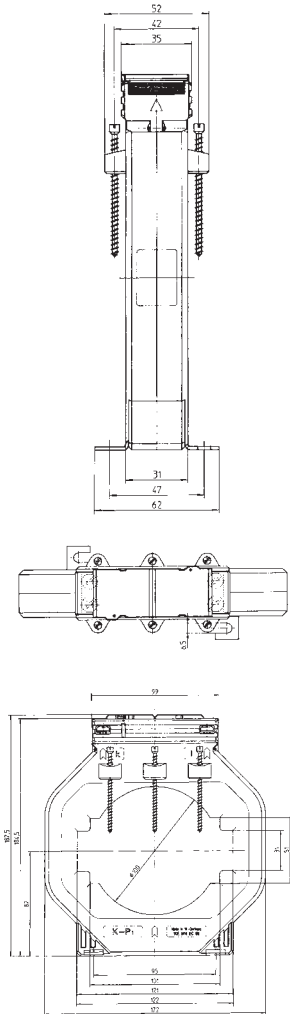
Secondary current		5A			1A	
Primary current A	Burden VA	Accuracy class			Accuracy class	
		0.5 Art.-no.	0.5s Art.-no.	0.2 Art.-no.	0.5 Art.-no.	0.2 Art.-no.
600	2.5	86568	86622	86515	86768	86715
	5	86569	86623	86516	86769	86716
750	2.5	86571	86625	86518	86771	86718
	5	86572	86626	86519	86772	86719
	10	86573	86627	86520	86773	86720
1000	2.5	86574				
	5	86575	86629	86522	86775	86722
	10	86576	86630	86523	86776	86723
	15	86577	86631	86524	86777	86724
1200	5	86579	86633	86526	86779	86726
	10	86580	86634	86527	86780	86727
	15	86581	86635	86528	86781	86728
1250	5	86583	86637	86530	86783	86730
	10	86584	86638	86531	86784	86731
	15	86585	86639	86532	86785	86732
	30	86586	86640		86786	
1500	5	86588	86642	86535	86788	86735
	10	86589	86643	86536	86789	86736
	15	86590	86644	86537	86790	86737
	30	86591	86645	86538	86791	86738
1600	5	86593	86647	86540		
	10	86594	86648	86541	86794	86741
	15	86595	86649	86542	86795	86742
	30	86596	86650	86543	86796	86743
2000	5	86598	86652	86545		
	10	86599	86653	86546	86799	86746
	15	86600	86654	86547	86800	86747
	30	86601	86655	86548	86801	86748
2500	5	86603	86657	86550		
	10	86604	86658	86551	86804	86751
	15	86605	86659	86552	86805	86752
	30	86606	86660	86553	86806	86753
3000	5		86662	86555		
	10	86609	86663	86556	86809	86756
	15	86610	86664	86557	86810	86757
	30	86611	86665	86558	86811	86758

Primary conductor	100 x 55 mm
Round conductor	Ø 55 mm
Transformer width	129 mm
Snap-on mounting	-
Sealed shutter	<b>Art.-no. 59042</b> see page 207
Current transformer for industrial applications	see page 88
Protection plug-in current transformers	see page 155

# EASK 123.3

## Plug-in current transformer

Approved current transformer for tariff applications



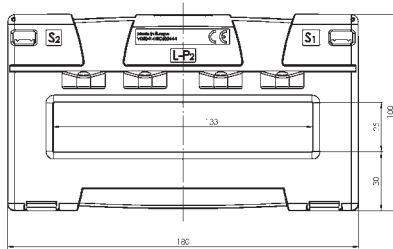
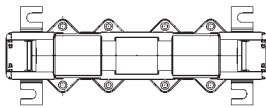
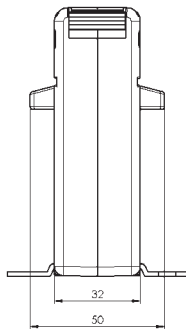
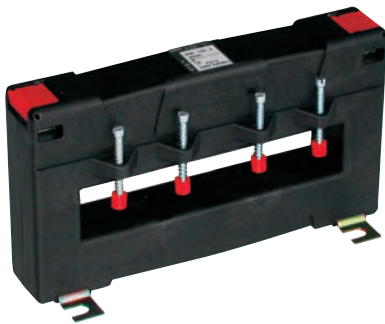
Secondary current		5A		
Primary current A	Burden VA	Accuracy class		
		0.5 Art.-no.	0.5s Art.-no.	0.2 Art.-no.
750	2.5	V56-2301D	V56-2302D	
	5	V56-2301F	V56-2302F	
	10	V56-2301H	V56-2302H	
1000	2.5	V56-2501D	V56-2502D	V56-2503D
	5	V56-2501F	V56-2502F	V56-2503F
	10	V56-2501H	V56-2502H	
1200	5	V56-2601F	V56-2602F	V56-2603F
	10	V56-2601H	V56-2602H	V56-2603H
	15	V56-2601J	V56-2602J	
1250	5	V56-2701F	V56-2702F	V56-2703F
	10	V56-2701H	V56-2702H	V56-2703H
	15	V56-2701J	V56-2702J	V56-2703J
1500	5	V56-2801F	V56-2802F	V56-2803F
	10	V56-2801H	V56-2802H	V56-2803H
	15	V56-2801J	V56-2802J	V56-2803J
	30	V56-2801L	V56-2802L	
1600	5	V56-2901F	V56-2902F	V56-2903F
	10	V56-2901H	V56-2902H	V56-2903H
	15	V56-2901J	V56-2902J	V56-2903J
	30	V56-2901L	V56-2902L	
2000	5	V56-3001F	V56-3002F	V56-3003F
	10	V56-3001H	V56-3002H	V56-3003H
	15	V56-3001J	V56-3002J	V56-3003J
	30	V56-3001L	V56-3002L	
2500	5	V56-3201F	V56-3202F	V56-3203F
	10	V56-3201H	V56-3202H	V56-3203H
	15	V56-3201J	V56-3202J	V56-3203J
	30	V56-3201L	V56-3202L	
3000	5	V56-3301F	V56-3302F	V56-3303F
	10	V56-3301H	V56-3302H	V56-3303H
	15	V56-3301J	V56-3302J	V56-3303J
	30	V56-3301L	V56-3302L	

Primary conductor	120 x 30 mm 3 x 100 x 10 mm
Round conductor	Ø 100 mm
Transformer width	172 mm
Snap-on mounting	-
Sealed shutter	<b>Art.-no. 59040</b> see page 207
Current transformer for industrial applications	see page 90

# EASK 130.3

## Plug-in current transformer

Approved current transformer for tariff applications



Secondary current		5A			1A	
Primary current A	Burden VA	Accuracy class			Accuracy class	
		0.5	0.5s	0.2	0.5	0.2
		Art.-no.	Art.-no.	Art.-no.	Art.-no.	Art.-no.
300	2.5	V50-1901D	V50-1902D		V50-1911D	
	5	V50-1901F			V50-1911F	
400	2.5	V50-2001D	V50-2002D	V50-2003D	V50-2011D	V50-2013D
	5	V50-2001F	V50-2002F		V50-2011F	
	10	V50-2001H			V50-2011H	
500	2.5	V50-2101D	V50-2102D	V50-2103D	V50-2111D	V50-2113D
	5	V50-2101F	V50-2102F		V50-2111F	
	10	V50-2101H			V50-2111H	
600	2.5	V50-2201D	V50-2202D	V50-2203D	V50-2211D	V50-2213D
	5	V50-2201F	V50-2202F	V50-2203F	V50-2211F	V50-2213F
	10	V50-2201H			V50-2211H	
750	2.5	V50-2301D	V50-2302D	V50-2303D	V50-2311D	V50-2313D
	5	V50-2301F	V50-2302F	V50-2303F	V50-2311F	V50-2313F
	10	V50-2301H	V50-2302H		V50-2311H	
	15	V50-2301J			V50-2311J	
1000	5	V50-2501F	V50-2502F	V50-2503F	V50-2511F	V50-2513F
	10	V50-2501H	V50-2502H	V50-2503H	V50-2511H	V50-2513H
	15	V50-2501J	V50-2502J		V50-2511J	
1200	5	V50-2601F	V50-2602F	V50-2603F	V50-2611F	V50-2613F
	10	V50-2601H	V50-2602H	V50-2603H	V50-2611H	V50-2613H
	15	V50-2601J	V50-2602J	V50-2603J	V50-2611J	V50-2613J
1250	5	V50-2701F	V50-2702F	V50-2703F	V50-2711F	V50-2713F
	10	V50-2701H	V50-2702H	V50-2703H	V50-2711H	V50-2713H
	15	V50-2701J	V50-2702J	V50-2703J	V50-2711J	V50-2713J
1500	5	V50-2801F	V50-2802F	V50-2803F	V50-2811F	V50-2813F
	10	V50-2801H	V50-2802H	V50-2803H	V50-2811H	V50-2813H
	15	V50-2801J	V50-2802J	V50-2803J	V50-2811J	V50-2813J
	30	V50-2801L			V50-2811L	
1600	5	V50-2901F	V50-2902F	V50-2903F	V50-2911F	V50-2913F
	10	V50-2901H	V50-2902H	V50-2903H	V50-2911H	V50-2913H
	15	V50-2901J	V50-2902J	V50-2903J	V50-2911J	V50-2913J
	30	V50-2901L	V50-2902L		V50-2911L	

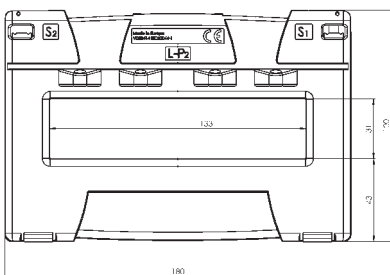
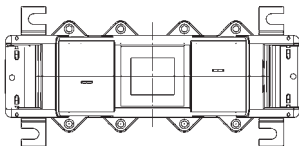
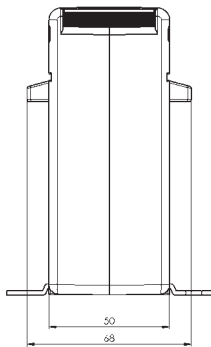
Primary conductor	130 x 25 mm
Round conductor	-
Transformer width	180 mm
Snap-on mounting	-
Sealed shutter	-
Current transformer for industrial applications	see page 96



# EASK 130.5

## Plug-in current transformer

Approved current transformer for tariff applications



Secondary current		5A			1A	
Primary current A	Burden VA	Accuracy class			Accuracy class	
		0.5	0.5s	0.2	0.5	0.2
		Art.-no.	Art.-no.	Art.-no.	Art.-no.	Art.-no.
300	2.5	V51-1901D	V51-1902D		V51-1911D	
	5	V51-1901F	V51-1902F		V51-1911F	
	10	V51-1901H			V51-1911H	
400	2.5	V51-2001D	V51-2002D	V51-2003D	V51-2011D	V51-2013D
	5	V51-2001F	V51-2002F		V51-2011F	
	10	V51-2001H	V51-2002H		V51-2011H	
500	2.5	V51-2101D	V51-2102D	V51-2103D	V51-2111D	V51-2113F
	5	V51-2101F	V51-2102F	V51-2103F	V51-2111F	
	10	V51-2101H	V51-2102H		V51-2111H	
	15	V51-2101J			V51-2111J	
600	2.5	V51-2201D	V51-2202D	V51-2203D	V51-2211D	V51-2213D
	5	V51-2201F	V51-2202F	V51-2203F	V51-2211F	V51-2213F
	10	V51-2201H	V51-2202H		V51-2211H	
	15	V51-2201J			V51-2211J	
750	2.5	V51-2301D	V51-2302D	V51-2303D	V51-2311D	V51-2313D
	5	V51-2301F	V51-2302F	V51-2303F	V51-2311F	V51-2313F
	10	V51-2301H	V51-2302H	V51-2303H	V51-2311H	V51-2313H
	15	V51-2301J	V51-2302J		V51-2311J	
1000	5	V51-2501F	V51-2502F	V51-2503F	V51-2511F	V51-2513F
	10	V51-2501H	V51-2502H	V51-2503H	V51-2511H	V51-2513H
	15	V51-2501J	V51-2502J	V51-2503J	V51-2511J	V51-2513J
	30	V51-2501L	V51-2502L		V51-2511L	
1200	5	V51-2601F	V51-2602F	V51-2603F	V51-2611F	V51-2613F
	10	V51-2601H	V51-2602H	V51-2603H	V51-2611H	V51-2613H
	15	V51-2601J	V51-2602J	V51-2603J	V51-2611J	V51-2613J
	30	V51-2601L	V51-2602L		V51-2611L	
1250	5	V51-2701F	V51-2702F	V51-2703F	V51-2711F	V51-2713F
	10	V51-2701H	V51-2702H	V51-2703H	V51-2711H	V51-2713H
	15	V51-2701J	V51-2702J	V51-2703J	V51-2711J	V51-2713J
	30	V51-2701L	V51-2702L		V51-2711L	
1500	5	V51-2801F	V51-2802F	V51-2803F	V51-2811F	V51-2813F
	10	V51-2801H	V51-2802H	V51-2803H	V51-2811H	V51-2813H
	15	V51-2801J	V51-2802J	V51-2803J	V51-2811J	V51-2813J
	30	V51-2801L	V51-2802L		V51-2811L	
1600	5	V51-2901F	V51-2902F	V51-2903F	V51-2911F	V51-2913F
	10	V51-2901H	V51-2902H	V51-2903H	V51-2911H	V51-2913H
	15	V51-2901J	V51-2902J	V51-2903J	V51-2911J	V51-2913J
	30	V51-2901L	V51-2902L		V51-2911L	
2000	10	V51-3001H	V51-3002H	V51-3003H	V51-3011H	V51-3013H
	15	V51-3001J	V51-3002J	V51-3003J	V51-3011J	V51-3013J
	30	V51-3001L	V51-3002L	V51-3003L	V51-3011L	V51-3013L
2400	10	V51-3101H	V51-3102H	V51-3103H	V51-3111H	V51-3113H
	15	V51-3101J	V51-3102J	V51-3103J	V51-3111J	V51-3113J
	30	V51-3101L	V51-3102L	V51-3103L	V51-3111L	V51-3113L
2500	10	V51-3201H	V51-3202H	V51-3203H	V51-3211H	V51-3213H
	15	V51-3201J	V51-3202J	V51-3203J	V51-3211J	V51-3213J
	30	V51-3201L	V51-3202L	V51-3203L	V51-3211L	V51-3213L
3000	10	V51-3301H	V51-3302H	V51-3303H	V51-3311H	V51-3313H
	15	V51-3301J	V51-3302J	V51-3303J	V51-3311J	V51-3313J
	30	V51-3301L	V51-3302L	V51-3303L	V51-3311L	V51-3313L

Primary conductor	130 x 30 mm
Round conductor	-
Transformer width	180 mm
Snap-on mounting	-
Sealed shutter	-
Current transformer for industrial applications	see page 97



## Low voltage current transformers for tariff applications

### Wound current transformers

<b>EWSK</b>	<b>31.5</b>	Transformer width	70 mm
-------------	-------------	-------------------	-------

---

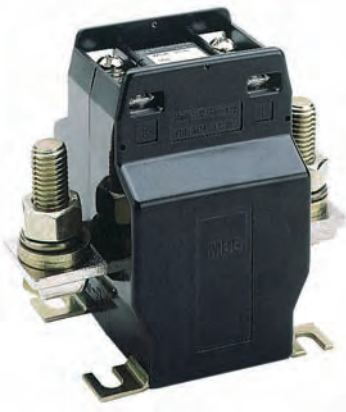
### Summation current transformers

<b>ESUSK</b>	<b>2...8</b>	Transformer width	156 mm
		Transformer depth	65 mm

---

see page 199

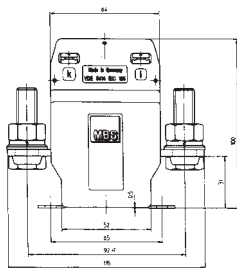
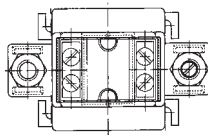
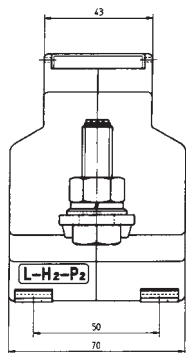
Type "E" denotes that the current transformers are for energy measurements.



# EWSK 31.5

## Wound current transformer

Approved current transformer for tariff applications



Secondary current		5A			1A	
Primary current A	Burden VA	Accuracy class			Accuracy class	
		0.5	0.5s	0.2	0.5	0.2
		Art.-no.	Art.-no.	Art.-no.	Art.-no.	Art.-no.
25	2.5	33547	33583	33511	33747	33711
	5	33548	33584	33512	33748	33712
	10	33549	33585	33513	33749	33713
	15	33550	33586		33750	
30	2.5	33551	33587	33515	33751	33715
	5	33552	33588	33516	33752	33716
	10	33553	33589	33517	33753	33717
	15	33554	33590		33754	
40	2.5	33555	33591	33519	33755	33719
	5	33556	33592	33520	33756	33720
	10	33557	33593	33521	33757	33721
	15	33558	33594		33758	
50	2.5	33559	33595	33523	33759	33723
	5	33560	33596	33524	33760	33724
	10	33561	33597	33525	33761	33725
	15	33562	33598		33762	
60	2.5	33563	33599	33527	33763	33727
	5	33564	33600	33528	33764	33728
	10	33565	33601	33529	33765	33729
	15	33566	33602		33766	
75	2.5	33567	33603	33531	33767	33731
	5	33568	33604	33532	33768	33732
	10	33569	33605	33533	33769	33733
	15	33570	33606		33770	
100	2.5	33571	33607	33535	33771	33735
	5	33572	33608	33536	33772	33736
	10	33573	33609	33537	33773	33737
	15	33574	33610		33774	
150	2.5	33575	33611	33539	33775	33739
	5	33576	33612	33540	33776	33740
	10	33577	33613	33541	33777	33741
	15	33578	33614		33778	

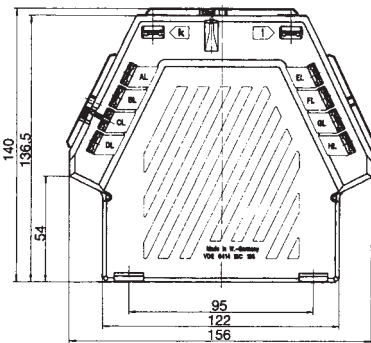
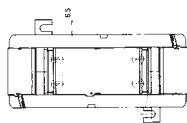
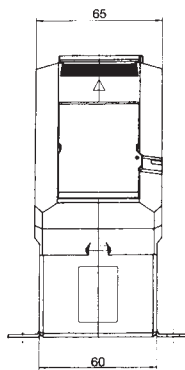
Primary conductor	—
Round conductor	—
Transformer width	70 mm
Snap-on mounting	—
Sealed shutter	<b>Art.-no. 59045</b> see page 207
Current transformer for industrial applications	see page 107



# ESUSK 2...8

## Summation current transformer

Approved current transformer for tariff applications

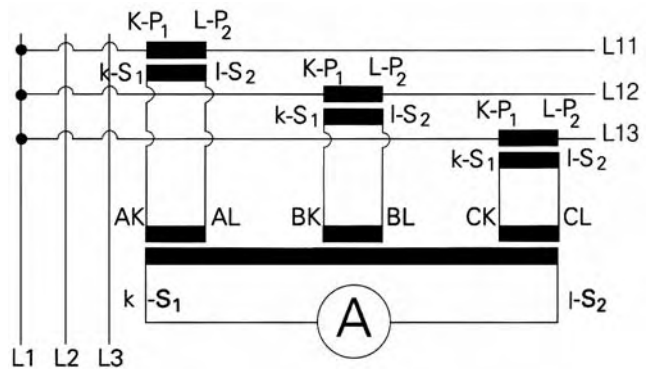


Secondary current			5A
Type	Primary current A	Burden VA	Accuracy class
			0.2
			Art.-no.
2	5+5	5	40511
		10	40512
3	5+5+5	5	40513
		10	40514
4	5+5+5+5	5	40515
		10	40516
5	5+5+5+5+5	5	40517
		10	40518
6	5+5+5+5+5+5	5	40519
		10	40529
7	5+5+5+5+5+5+5	5	40521
		10	40522
8	5+5+5+5+5+5+5+5	5	40523
		10	40524

Connection example for different ratios:

- AK-AL = 1000/5
- BK-BL = 800/5
- CK-CL = 600/5
- DK-DL = 400/5
- EK-EL = 400/5
- FK-FL = 300/5
- GK-GL = 300/5
- HK-HL = 300/5

Connection diagram



Primary conductor	—
Round conductor	—
Transformer width	65 mm
Transformer depth	156 mm
Snap-on mounting	—
Sealed shutter secondary no.	Art.-no. 59041 (primary) Art.-no. 59042 (secondary) see page 207
Current transformer for industrial applications	see page 117

For technical information see page 114 and 115.



# Plug-in current transformers for tariff applications

## Three-phase current transformer sets

**EASK(D) 21.3** with Plexiglas caps

---

**EASK(D) 31.5** with Plexiglas caps

**EASK(D) 31.5 2u**

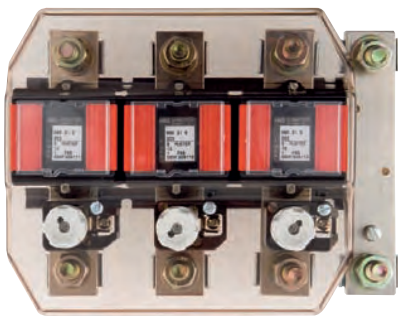
---

**EWSKD 31.8** with Plexiglas caps

**EASKD 31.8**

---

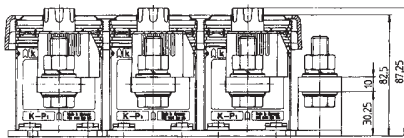
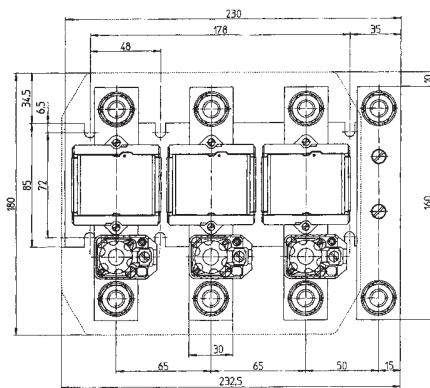




# EASK(D) 31.5

## Three-phase current transformer set

Approved current transformer for tariff applications



Technical description see page 160.

Secondary current		5A			1A	
Primary current A	Burden VA	Accuracy class			Accuracy class	
		0.5	0.5s	0.2	0.5	0.2
		Art.-no.	Art.-no.	Art.-no.	Art.-no.	Art.-no.
3 x 75	2.5	57543	57575		57743	
	5					
3 x 100	2.5	57544	57576	57512	57744	57712
	5	57545			57745	
3 x 150	2.5	57546	57578	57514	57746	57714
	5	57547	57579	57515	57747	57715
3 x 200	2.5	57548	57580	57516	57748	57716
	5	57549	57581	57517	57749	57717
	10	57550	57582		57750	
3 x 250	2.5	57551	57583	57519	57751	57719
	5	57552	57584	57520	57752	57720
	10	57553	57585	57521	57753	57721
	15	57554	57806		57754	
3 x 300	2.5	57555	57586	57523	57755	57723
	5	57556	57587	57524	57756	57724
	10	57557	57588	57525	57757	57725
	15	57558	57805		57758	
3 x 400	2.5	57559	57589	57527	57759	57727
	5	57560	57590	57528	57760	57728
	10	57561	57591	57529	57761	57729
	15	57562	57592		57762	
3 x 500	2.5	57563	57593	57531	57763	57731
	5	57564	57594	57532	57764	57732
	10	57565	57595	57533	57765	57733
	15	57566	57596		57766	
3 x 600	2.5	57567	57597	57535	57767	57735
	5	57568	57598	57536	57768	57736
	10	57569	57599	57537	57769	57737
	15	57570	57600		57770	
3 x 750	2.5	57571	57601	57539	57771	57739
	5	57572	57602	57540	57772	57740
	10	57573	57603	57541	57773	57741
	15	57574	57604	57542	57774	57742

# EASK(D) 31.5 2u

## Plug-in secondary change-over current transformer set

Secondary current		5A	
Primary current A	Burden VA	Accuracy class	
		0.5	0.5s
		Art.-no.	Art.-no.
3x200-100	5-2.5	57605	57615
	10-5	57606	
3x300-150	5-2.5	57607	57617
	10-5	57608	57618
3x400-200	5-2.5	57609	57619
	10-5	57610	57620
3x500-250	5-2.5	57611	57621
	10-5	57612	57622
3x600-300	5-2.5	57613	57623
	10-5	57614	57624

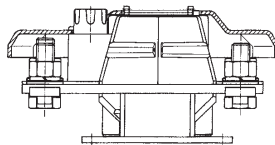
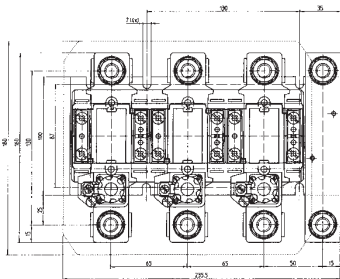
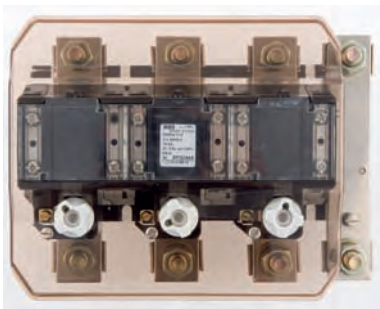


# EASKD 31.8

## Three-phase current transformer set

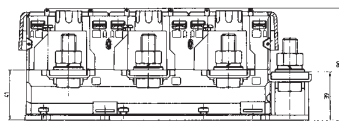
Approved current transformer for tariff applications

with base plate



Secondary current		5A			1A	
Primary current A	Burden VA	Accuracy class			Accuracy class	
		0.5 Art.-no.	0.5s Art.-no.	0.2 Art.-no.	0.5 Art.-no.	0.2 Art.-no.
3 x 200	2.5	46577	46617	46527	46777	46727
	5	46578	46618	46528	46778	46728
	10	46579	46619	46529	46779	46729
3 x 250	2.5	46581	46621	46531	46781	46731
	5	46582	46622	46532	46782	46732
	10	46583	46623	46533	46783	46733
3 x 300	2.5	46585	46625	46535	46785	46735
	5	46586	46626	46536	46786	46736
	10	46587	46627	46537	46787	46737
	15	46588	46628		46788	
3 x 400	2.5	46589	46629	46539	46789	46739
	5	46590	46630	46540	46790	46740
	10	46591	46631	46541	46791	46741
	15	46592	46632	46542	46792	46742
3 x 500	2.5	46593	46633	46543	46793	46743
	5	46594	46634	46544	46794	46744
	10	46595	46635	46545	46795	46745
	15	46596	46636	46546	46796	46746
3 x 600	2.5	46597	46637	46547	46797	46747
	5	46598	46638	46548	46798	46748
	10	46599	46639	46549	46799	46749
	15	46600	46640	46550	46800	46750

without base plate and neutral conductor



Secondary current		5A			1A	
Primary current A	Burden VA	Accuracy class			Accuracy class	
		0.5 Art.-no.	0.5s Art.-no.	0.2 Art.-no.	0.5 Art.-no.	0.2 Art.-no.
3 x 200	2.5	47577	47617	47527	47777	47727
	5	47578	47618	47528	47778	47728
	10	47579	47619	47529	47779	47729
3 x 250	2.5	47581	47621	47531	47781	47731
	5	47582	47622	47532	47782	47732
	10	47583	47623	47533	47783	47733
3 x 300	2.5	47585	47625	47535	47785	47735
	5	47586	47626	47536	47786	47736
	10	47587	47627	47537	47787	47737
	15	47588	47628		47788	
3 x 400	2.5	47589	47629	47539	47789	47739
	5	47590	47630	47540	47790	47740
	10	47591	47631	47541	47791	47741
	15	47592	47632	47542	47792	47742
3 x 500	2.5	47593	47633	47543	47793	47743
	5	47594	47634	47544	47794	47744
	10	47595	47635	47545	47795	47745
	15	47596	47636	47546	47796	47746
3 x 600	2.5	47597	47637	47547	47797	47747
	5	47598	47638	47548	47798	47748
	10	47599	47639	47549	47799	47749
	15	47600	47640	47550	47800	47750



# Accessories for low voltage current transformers

**Snap-on mountings**

---

**Copper tubes**

---

**Mounting angles**

---

**Mounting kits**

---

**Secondary cap**

---

**Locking pistons**

---

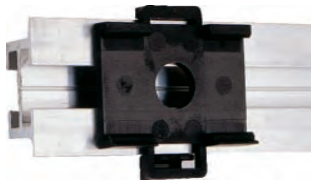
**Sealed shutters**

---

**Copper bus bars**

---

# Snap-on mountings



Snap-on mounting for tube-, plug-in, protection- and tariff transformers	
For use with MBS current transformers	Art.-no.
ASR 22.3; ASK 21.3; 31.3; 318.3; 41.3; WSK 30	53011
ASK 31.4	54011
ASK 31.5; WSK 40 N; ASK 41.5	55011
ASK 41.4; 412.4; WSK 40	55012
ASR 14.3; 20.3; 201.3	55013
ASR 21.3; ASK 205.3	55014

# Copper tubes



Copper tube				
Length	Outside Ø	Inner Ø	Max. current	Art.-no.
34	22.5	16.5	600 A	52011
36	22.5	16.5	600 A	52012
different lengths available upon request				
34	22.5	12.5	600 A	52021
36	22.5	12.5	600 A	52022
different lengths available upon request				
34	22.5	8.5	600 A	52031
36	22.5	8.5	600 A	52032
different lengths available upon request				
32	21	12.5	600 A	52041
34	21	12.5	600 A	52042
different lengths available upon request				
32	21	8.5	600 A	52051
34	21	8.5	600 A	52052
different lengths available upon request				

# Mounting angle for 3-phase current transformer set



Mounting angle for triple set (2 pcs) plug-in, protection- and tariff transformers	
For use with MBS current transformers	Art.-no.
ASK 421.4; 41.4; 412.4; WSK 40; WSK 40 N	59037
ASK 41.5	59082

## Mounting kits



Mounting kit	
Screw M 12 x 40	Art.-no.
with voltage taps M5	59026
with voltage taps M5 and locking piston bus bar 30 mm	59027
with voltage taps M5 and locking piston bus bar 40 mm	59030
with voltage taps M5 and locking piston bus bar 50 mm	59081
standard	59028
standard with locking piston bus bar 30 mm	59029
standard with locking piston bus bar 40 mm	59030A
standard with locking piston bus bar 50 mm	59080

## Secondary cap



Secondary cap
Art.-no.
53016

## Locking pistons



	Dimensions [mm]			Art.-no.
	30 x 6	30 x 8	30 x 10	
copper bus bar	30 x 6	30 x 8	30 x 10	59035
copper bus bar	40 x 6	40 x 8	40 x 10	59036
copper bus bar	50 x 6	50 x 8	50 x 10	59048

## Sealed shutters



Sealed shutters for use with MBS current transformers	
For use with MBS current transformers	Art.-no.
ASR 22.3; ASK 21.3; 31.3; 318.3; 41.3; 103.3 (2x); 123.3 (2x); WSK 30	59040
ASK 31.4; 31.5; 421.4; 41.4; 41.5; 412.4; WSK 40; 60; WSK 40 N; KSU; SUSK	59041
ASK 541.4; 51.4; 561.4; 61.4; 63.4; 63.6; 81.4; 101.4; SUSK	59042
ASK 105.6; 105.6N; 127.4; 127.6; 128.4; 129.10	59042
WSK 70.6	59043
ASK 31.6; 41.6; 51.6; 61.6	59044
WSK 31.5	59045

# Copper bus bars

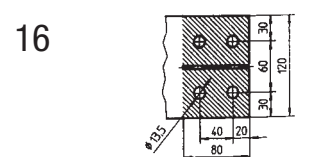
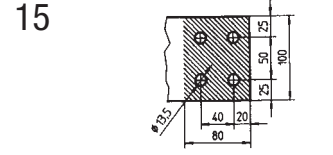
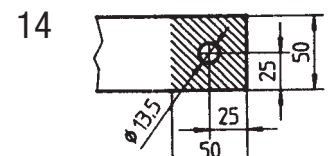
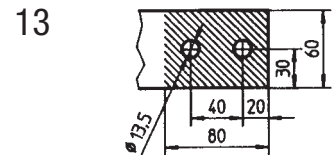
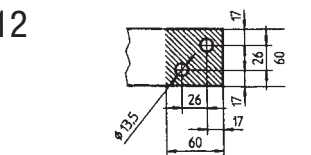
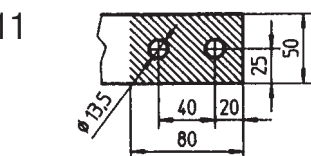
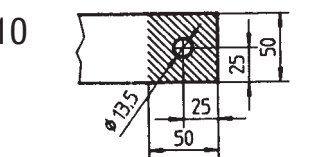
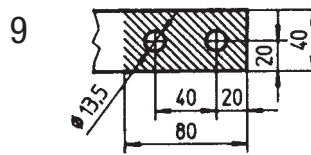
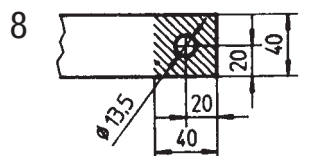
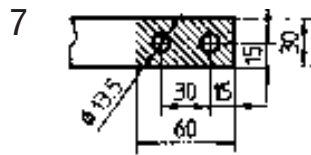
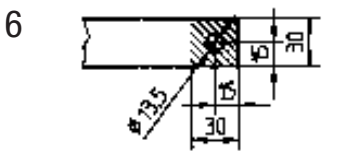
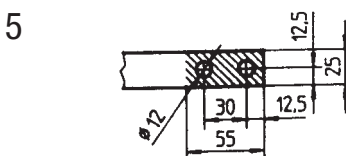
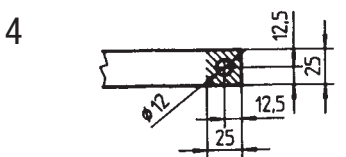
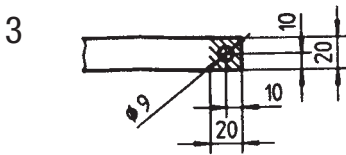
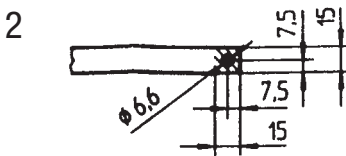
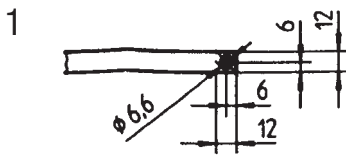
galvanically nickel-plated



Copper bus bar for current transformers for industrial applications



Copper bus bar for current transformers for tariff applications



Material E-Cu copper plated acc. to DIN 46433

# Copper bus bars

Art.-no.	Configuration	Bores	Length	Width	Thickness	Max. current
020060170B003I	industry	3	170	20	6	300 A
020060170B003IO	w/o screws	3	170	20	6	300 A
030060130B006I	industry	6	130	30	6	300 A
030060130B006E	energy supplier	6	130	30	6	300 A
030060130B006IO	w/o screws	6	130	30	6	300 A
030060140B006I	industry	6	140	30	6	300 A
030060140B006E	energy supplier	6	140	30	6	300 A
030060140B006IO	w/o screws	6	140	30	6	300 A
030080130B006I	industry	6	130	30	8	400 A
030080130B006E	energy supplier	6	130	30	8	400 A
030080130B006IO	w/o screws	6	130	30	8	400 A
030080160B006I	industry	6	160	30	8	400 A
030080160B006E	energy supplier	6	160	30	8	400 A
030080160B006IO	w/o screws	6	160	30	8	400 A
030100130B006I	industry	6	130	30	10	750 A
030100130B006E	energy supplier	6	130	30	10	750 A
030100130B006IO	w/o screws	6	130	30	10	750 A
030100140B006I	industry	6	140	30	10	750 A
030100140B006E	energy supplier	6	140	30	10	750 A
030100140B006IO	w/o screws	6	140	30	10	750 A
030100160B006I	industry	6	160	30	10	750 A
030100160B006E	energy supplier	6	160	30	10	750 A
030100160B006IO	w/o screws	6	160	30	10	750 A
040060140B008I	industry	8	140	40	6	500 A
040060140B008E	energy supplier	8	140	40	6	500 A
040060140B008IO	w/o screws	8	140	40	6	500 A
040060160B008I	industry	8	160	40	6	500 A
040060160B008E	energy supplier	8	160	40	6	500 A
040060160B008IO	w/o screws	8	160	40	6	500 A
040100140B008I	industry	8	140	40	10	800 A
040100140B008E	energy supplier	8	140	40	10	800 A
040100140B008IO	w/o screws	8	140	40	10	800 A
040100160B008I	industry	8	160	40	10	800 A
040100160B008E	energy supplier	8	160	40	10	800 A
040100160B008IO	w/o screws	8	160	40	10	800 A
050100140B010I	industry	10	140	50	10	1000 A
050100140B010E	energy supplier	10	140	50	10	1000 A
050100140B010IO	w/o screws	10	140	50	10	1000 A
050100180B010I	industry	10	180	50	10	1000 A
050100180B010E	energy supplier	10	180	50	10	1000 A
050100180B010IO	w/o screws	10	180	50	10	1000 A
050100220B011I	industry	11	220	50	10	1000 A
050100220B011E	energy supplier	11	220	50	10	1000 A
050100220B011IO	w/o screws	11	220	50	10	1000 A
060100180B012I	industry	12	180	60	10	1200 A
060100180B012E	energy supplier	12	180	60	10	1200 A
060100180B012IO	w/o screws	12	180	60	10	1200 A
060100220B013I	industry	13	220	60	10	1200 A
060100220B013E	energy supplier	13	220	60	10	1200 A
060100220B013IO	w/o screws	13	220	60	10	1200 A
080100240B014I	industry	14	240	80	10	1500 A
080100240B014E	energy supplier	14	240	80	10	1500 A
080100240B014IO	w/o screws	14	240	80	10	1500 A
100100240B015I	industry	15	240	100	10	2000 A
100100240B015E	energy supplier	15	240	100	10	2000 A
100100240B015IO	w/o screws	15	240	100	10	2000 A

Primary bus bars – delivery content:

energy suppliers = with 1 off each mounting kit, nos. 59026 and 59028

industry = with 2 mounting kits, no. 59028

w/o = without screws.

Additional lengths and special bores upon request.



# Bus bar isolators / Bus bar supports

**DB/P**    **Spacing isolators**  
**C0/P**  
**CS/P**  
**CT/P**  
**CPE**

---

**PI/P**    **Passing isolators**

---

**PSB**    **Vertical bus bar supports**

---

**GB**    **Mounting materials**  
**Threaded bolts**

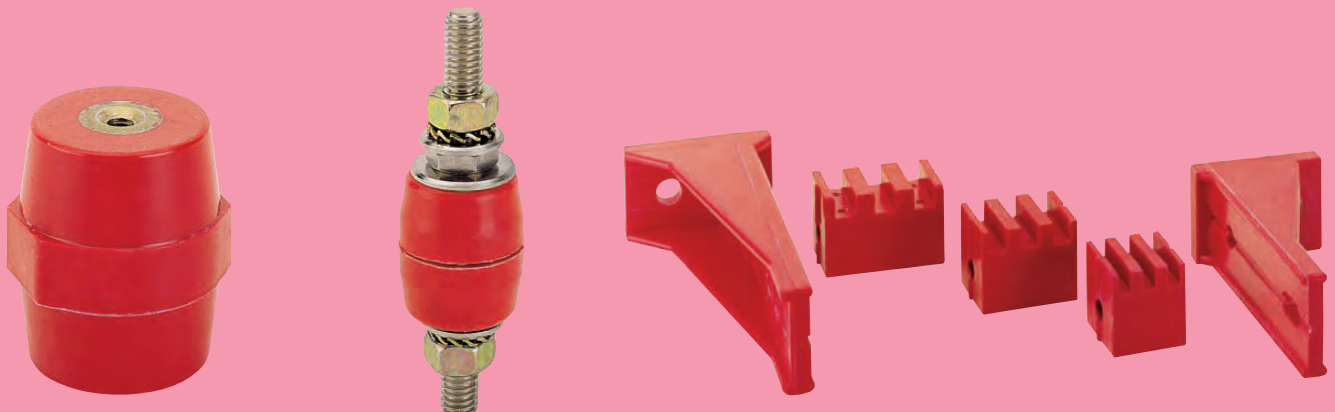
---

**SK**    **Hexagon spacers in brass**

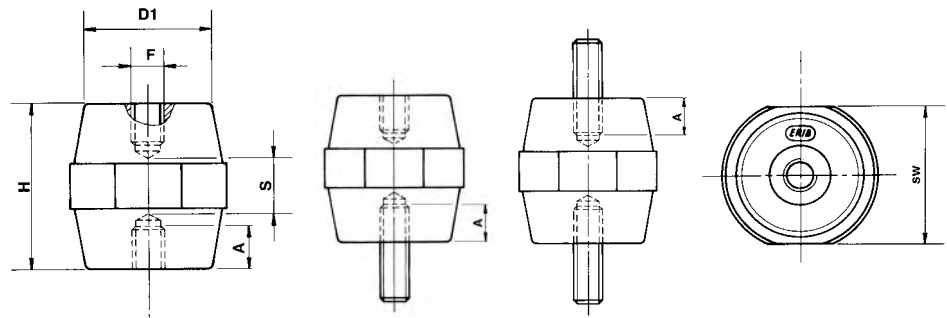
---

**Bus bar supports**  
**Bus bar supports L-profile**  
**Bus bar supports Z-profile**

---



# Spacing isolator type DB/P



art.-no. XXXXX  
e.g. 90015

art.-no. XXXXX-1  
e.g. 90015-1

art.-no. XXXXX-2  
e.g. 90015-2

## DB/P

Made of Polyglas-Polyester material, reinforced with fibreglass, colour red, self extinguishing. The isolators of type DB are unbreakable and have excellent electrical and mechanical characteristics and can be used under extreme working conditions such as high room temperatures, also when in contact with corrosive substances, vibrations, etc. The hexagon, arranged middle layer with two facing sides, facilitates the connection and locking in place the isolator. Upon request, the isolators can be supplied as follows:

- The isolator can be equipped with a thread which is not standard
- The isolator can be supplied with one or two threaded bolts "GB"

Operating temperature:  
-40 °C to +130 °C

Fire resistance:  
Class UL94-VO

Art.-no.	Packaging-unit	Article-group	Article	H (mm)	sw* (mm)	D1 (mm)	Operating voltage	M (thread)	A (mm)	Colour
90015	100	DB	12/P	12	11	10	220	M3	3	■
90018	100	DB	12/P	12	11	10	220	M4	3	■
90022	100	DB	16/P	16	14	13	380	M4	4	■
90025	100	DB	20/P	20	17	15	500	M4	6	■
90026	100	DB	20/P	20	17	15	500	M6	6	■
90028	250	DB	25/P	25	19	15	600	M6	7	■
90029	250	DB	25/P	25	19	15	600	M5	7	■
90030	250	DB	25/P	25	19	15	600	M6	7	■
90033	80	DB	30/P	30	30	26	600	M6	8	■
90034	80	DB	30/P	30	30	26	600	M8	7	■
90035	64	DB	34/P	35	32	28	1000	M6	9	■
90036	64	DB	34/P	35	32	28	1000	M8	10	■
90037	64	DB	34/P	35	32	28	1000	M10	10	■
90038	36	DB	35/P	35	41	35	1000	M6	9	■
90039	36	DB	35/P	35	41	35	1000	M8	9	■
90040	36	DB	35/P	35	41	35	1000	M10	10	■
90438	100	DB	40/P	40	40	30	1000	M8	11	■
90439	100	DB	40/P	40	40	30	1000	M10	12	■
90440	100	DB	40/P	40	40	30	1000	M12	10	■
90041	27	DB	45/P	45	41	35	1500	M6	12	■
90042	27	DB	45/P	45	41	35	1500	M8	12	■
90043	27	DB	45/P	45	41	35	1500	M10	12	■
90044	27	DB	45/P	45	41	35	1500	M12	12	■
90046	36	DB	50/P	50	36	29	2000	M8	12	■
90047	36	DB	50/P	50	36	29	2000	M10	12	■
90048	36	DB	50/P	50	36	29	2000	M12	13	■
90441	25	DB	60/P	60	55	40	2000	M8	20	■
90442	25	DB	60/P	60	55	40	2000	M10	21	■
90443	25	DB	60/P	60	55	40	2000	M12	20	■
90050	22	DB	65/P	63.5	41	35	3000	M8	17	■
90051	22	DB	65/P	63.5	41	35	3000	M10	19	■
90052	22	DB	65/P	63.5	41	35	3000	M12	19	■
90053	12	DB	75/P	76	50	36	5000	M8	19	■
90054	12	DB	75/P	76	50	36	5000	M10	19	■
90055	12	DB	75/P	76	50	36	5000	M12	19	■
90057	8	DB	750/P	75	65	52	5000	M12	18	■
90058	8	DB	750/P	75	65	52	5000	M16	23	■

\* sw = screw wide

For mounting and assembly material see page 219.

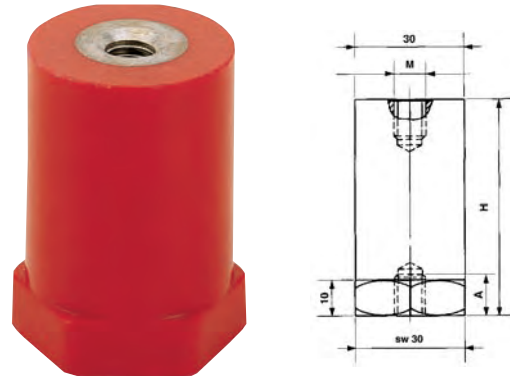
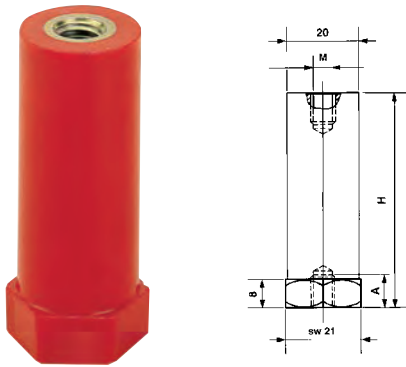
## Spacing isolator type DB/P

	DB16P	DB 20/P	DB 25/P	DB 30/P	DB 34/P	DB 35/P	DB45/P	DB 50/P	DB 65/P	DB 75/P	DB 750/P
resistance voltage tracking [kV]	3	4	7	8	10	10	12	12	15	25	25
discharge voltage [kV]	8	15	20	23	30	30	40	40	40	50	50
max. tensile load fz [kIM]	1	1.5	3	5	8	11	12	8.5	15	23	28
max. bending load fb [kIM]	0.5	0.6	1.8	2.5	4.5	8	8	4.5	7	9	15
max. compression load fd [kIM]	5	6	21	44	65	80	80	68	83	100	150
max. starting torque md [Nm]	0.4	0.4	3	3	5	9	10	5	6	10	13

The types DB ..., CO/P..., CS/P..., CT/P... and CPE ... have been tested for insulating material (discharge voltage, discharge strength and arking) according to the regulations covering VDE 0303 part 2 blueprint march 1987. Appraisal of the discharge voltage or arking between two unequal electrodes / diameter (25 mm or 75 mm). The test was made for the norm climate 23/50, ambient temperature (23 ± 2) °C and (50 ± 5) % relative humidity.

**Spacing isolator type CO/P – 20 mm dia.**

**Spacing isolator type CS/P – 30 mm dia.**



**CO/P – diameter 20 mm**

Made of Polyglass-Polyester material, reinforced fibre glass, colour red, self extinguishing. Upon request the isolators type CO/P, can be supplied with 1 or 2 mounting materials, type GB, fitted and secured with lock tide.

**CS/P – diameter 30 mm**

Made of Polyglass-Polyester material, reinforced fibre glass, colour red, self extinguishing.

Art.-no.	Packaging-unit	Article group	Article	H (mm)	D (mm)	Operating voltage	M (thread)	A (mm)
90061	200	CO/P	16	16	20	220	M4	4
90062	200	CO/P	16	16	20	220	M5	4
90063	100	CO/P	16	16	20	220	M6	4
90064	150	CO/P	16	16	20	220	M8	4
90065	200	CO/P	20	20	20	400	M5	5
90066	100	CO/P	20	20	20	400	M6	5
90067	200	CO/P	20	20	20	400	M8	5
90068	150	CO/P	25	25	20	500	M5	6
90069	150	CO/P	25	25	20	500	M6	6
90070	150	CO/P	25	25	20	500	M8	6
90071	140	CO/P	30	30	20	600	M5	7
90072	140	CO/P	30	30	20	600	M6	7
90073	140	CO/P	30	30	20	600	M8	7
90075	120	CO/P	35	35	20	600	M6	7
90077	110	CO/P	40	40	20	600	M6	9
90078	110	CO/P	40	40	20	600	M8	10
90079	100	CO/P	45	45	20	750	M6	9
90080	100	CO/P	45	45	20	750	M8	10
90081	80	CO/P	50	50	20	750	M6	10
90082	80	CO/P	50	50	20	750	M8	10
90083	70	CO/P	60	60	20	750	M6	9
90084	70	CO/P	60	60	20	750	M8	9

Art.-no.	Packaging-unit	Article group	Article	H (mm)	D (mm)	Operating voltage	M (thread)	A (mm)
90087	80	CS/P	30	30	30	750	M6	9
90088	80	CS/P	30	30	30	750	M8	9
90089	80	CS/P	30	30	30	750	M10	9
90090	64	CS/P	35	35	30	1000	M6	9
90091	64	CS/P	35	35	30	1000	M8	9
90092	64	CS/P	35	35	30	1000	M10	9
90093	60	CS/P	40	40	30	1000	M6	12
90094	60	CS/P	40	40	30	1000	M8	12
90095	60	CS/P	40	40	30	1000	M10	12
90096	48	CS/P	45	45	30	1000	M6	12
90097	48	CS/P	45	45	30	1000	M8	12
90098	48	CS/P	45	45	30	1000	M10	13
90099	48	CS/P	50	50	30	1500	M6	12
90100	48	CS/P	50	50	30	1500	M8	13
90101	48	CS/P	50	50	30	1500	M10	12
90102	40	CS/P	55	55	30	1500	M6	12
90103	40	CS/P	55	55	30	1500	M8	11
90105	40	CS/P	60	60	30	1500	M6	12
90106	40	CS/P	60	60	30	1500	M8	16
90107	40	CS/P	60	60	30	1500	M10	20
90109	32	CS/P	65	65	30	1500	M8	18
90111	32	CS/P	70	70	30	1500	M6	14
90112	32	CS/P	70	70	30	1500	M8	18
90113	32	CS/P	70	70	30	1500	M10	18

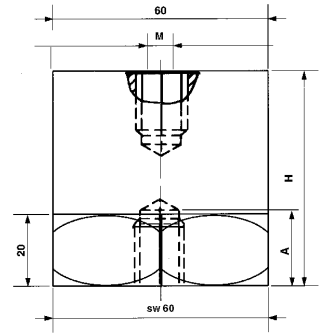
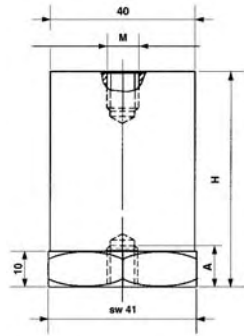
Spacing isolators type CO/P, CS/P, CT/P, CPE

Operating temperature -40 °C up to +130 °C

Fire resistance class UL94-V0

**Spacing isolator type CT/P – 40 mm dia.**

**Spacing isolator type CPE – 60 mm dia.**



**CT/P – diameter 40 mm**

Made of Polyglass-Polyester material, reinforced fibre glass, colour red, self extinguishing.

**CPE – diameter 60 mm**

Made of Polyglass-Polyester material, reinforced fibre glass, colour red, self extinguishing.

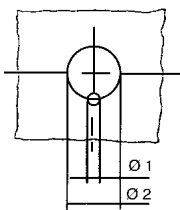
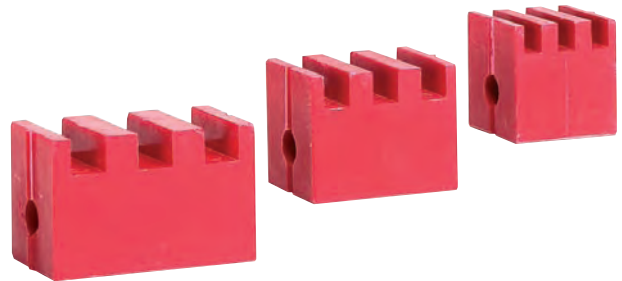
Art.-no.	Packaging-unit	Article group	Article	H (mm)	D (mm)	Operating voltage	M (thread)	A (mm)
90118	45	CT/P	30	30	40	750	M8	8
90119	45	CT/P	30	30	40	750	M10	9
90120	36	CT/P	35	35	40	750	M8	9
90121	36	CT/P	35	35	40	750	M10	9
90122	27	CT/P	40	40	40	1000	M8	12
90123	27	CT/P	40	40	40	1000	M10	12
90123M12	27	CT/P	40	40	40	1000	M12	12
90124	27	CT/P	45	45	40	1000	M8	13
90125	27	CT/P	45	45	40	1000	M10	12
90126	27	CT/P	50	50	40	1500	M8	12
90127	27	CT/P	50	50	40	1500	M10	13
90127M12	27	CT/P	50	50	40	1500	M12	11
90129	18	CT/P	55	55	40	1500	M10	12
90130	18	CT/P	60	60	40	1500	M8	18
90131	18	CT/P	60	60	40	1500	M10	18
90131M12	18	CT/P	60	60	40	1500	M12	18
90133	18	CT/P	65	65	40	1500	M10	18
90134	18	CT/P	70	70	40	1500	M8	18
90135	18	CT/P	70	70	40	1500	M10	18

Art.-no.	Packaging-unit	Article group	Article	H (mm)	D (mm)	Operating voltage	M (thread)	A (mm)
90140	12	CPE	40	40	60	1500	M10	11
90141	12	CPE	40	40	60	1500	M12	11
90142	12	CPE	40	40	60	1500	M16	12
90143	10	CPE	60	60	60	3000	M10	18
90144	10	CPE	60	60	60	3000	M12	18
90145	10	CPE	60	60	60	3000	M16	19
90146	8	CPE	80	80	60	5000	M10	19
90147	8	CPE	80	80	60	5000	M12	19
90148	8	CPE	80	80	60	5000	M16	23
90149	5	CPE	100	100	60	8000	M10	19
90150	5	CPE	100	100	60	8000	M12	19
90151	5	CPE	100	100	60	8000	M16	23

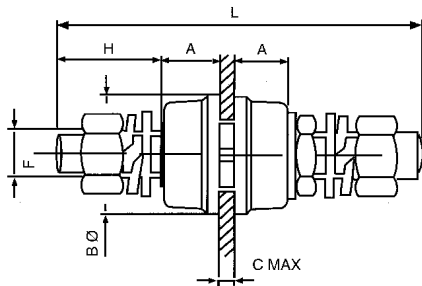
	CS/P 30	CS/P 40	CS/P 50	CS/P 60	CT/P 30	CT/P 40	CT/P 50	CT/P 60	CPE 40	CPE 60	CPE 80	CPE 100	CO/P 30	CO/P 40	CO/P 50	CO/P 60
resistance voltage tracking [kV]	8	8	10	15	8	10	10	10	10	20	25	30	5	8	10	10
discharge voltage [kV]	20	25	35	35	20	25	35	35	25	50	50	50	15	20	25	30
max. tensile load FZ [kN]	9	9	9	9	10	10	10	10	11	15	23	30	4	4	4	4
max. bending load FB [kN]	4.5	3	2	1.5	7.5	7	5	3.7	7	5	9	15	2	1.5	1	1
max. compression load FD [kN]	40	40	40	40	80	80	80	80	100	100	120	150	21	21	21	21
max. starting torque MD [Nm]	1.3...2.6	1.3...2.6	1.3...2.6	1.3...2.6	3.0...6.0	3.0...6.0	3.0...6.0	3.0...6.0	6	8	10	15	1.0...2.0	1.0...2.0	1.0...2.0	1.0...2.0

Passing isolators type PI/P

Vertical bus bar support type PSB



panel bore



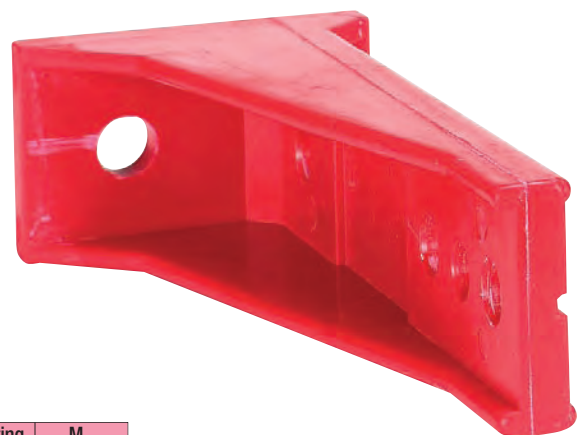
Passing isolator type PI/P  
Polyester material, red

Easy to assemble vertical bus bar support in Polyester material with reinforced fibre glass, red, suitable for bus bars with dimensions between 40 x 60 mm and 120 x 10 mm.

Due to its construction characteristics this bus bar support is suitable for special isolating and mechanical requirements.

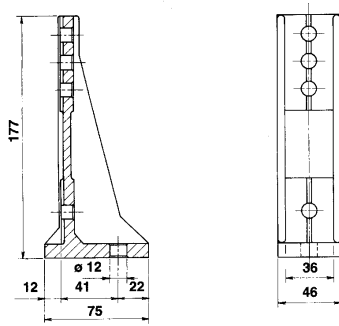
For the assembly of a bus bar support the following parts are required:

1 or 2 lateral supports, 2 mounting screws and the necessary blocknumber to clamp into place the required bus bars.

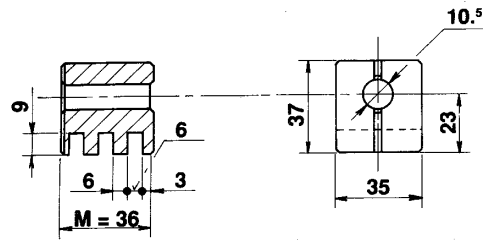


Art.-no.	Packaging-unit	Article group	Article	H (mm)	D (mm)	D1 (mm)	D2 (mm)	Cmax (mm)	Operating voltage	M (thread)
90166	60	PI/P	4	50	15	2.0	8.5	2.0	600	M4
90167	40	PI/P	6	65	22	3.0	12.0	3.0	1000	M6
90168	25	PI/P	8	80	25	3.0	15.0	4.0	1000	M8
90169	20	PI/P	10	95	30	4.0	17.0	4.0	1000	M10
90170	15	PI/P	12	105	35	4.5	20.0	4.0	1000	M12
90171	8	PI/P	16	135	43	5.0	25.0	8.0	2000	M16
90172	4	PI/P	20	155	54	5.5	31.0	10.0	2000	M20

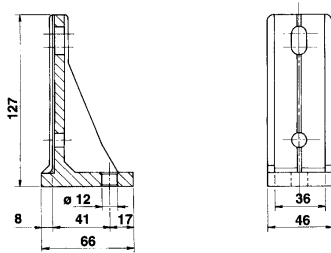
**PSB/1**  
lateral support



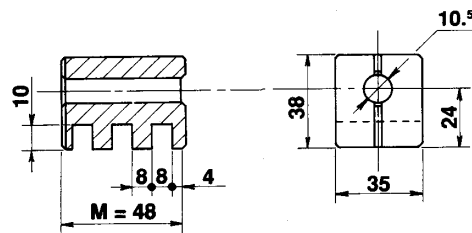
**PSB/6**  
block for 6 mm bus bar



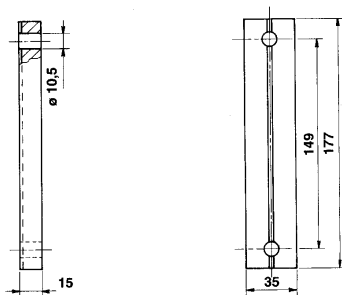
**PSB/2**  
lateral support



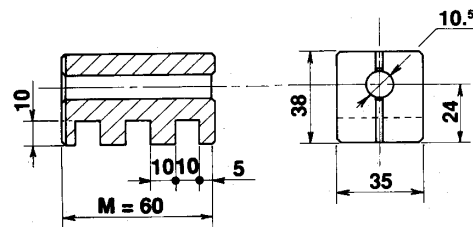
**PSB/8**  
block for 8 mm bus bar



**PSB/120**  
lateral support



**PSB/10**  
block for 10 mm bus bar



Lateral support	Blocks	Bus bars			Art.-no.
PSB/1	PSB 6	60 x 6	80 x 6	100 x 6	90175*
	PSB 8	60 x 8	80 x 8	100 x 8	
	PSB 10	60 x 10	80 x 10	100 x 10	
PSB/2	PSB 6	40 x 6	50 x 6		90176*
	PSB 8	40 x 8	50 x 8		
	PSB 10	40 x 10	50 x 10		
PSB/120	PSB 6	120 x 6			90177*
	PSB 8	120 x 8			
	PSB 10	120 x 10			

Elastic deviation of the teeth with signs of rupture			Pack.	Art.-no.
PSB/6	kg	950	36	90178*
PSB/8	kg	1130	30	90179*
PSB/10	kg	1375	24	90180*

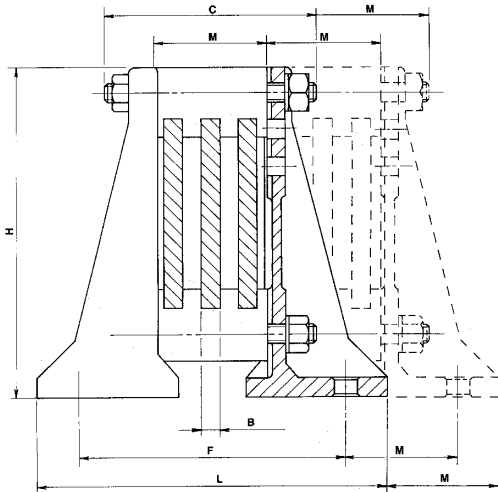
\* = storage parts

Operating voltage 1000 V AC  
 Operating temperature  $-40\text{ °C} \leq \vartheta \leq +130\text{ °C}$   
 Fire resistance class UL94-VO

Art.-no.	Packaging-unit	Article group	H (mm)	D (mm)	Operating voltage	For thread
90175	96	PSB/1	177	46	1000	M10
90176	144	PSB/2	127	46	1000	M10
90177	244	PSB/120	177	35	1000	M10
90178	36	PSB/6	37	36	1000	M10
90179	30	PSB/8	38	48	1000	M10
90180	24	PSB/10	38	60	1000	M10

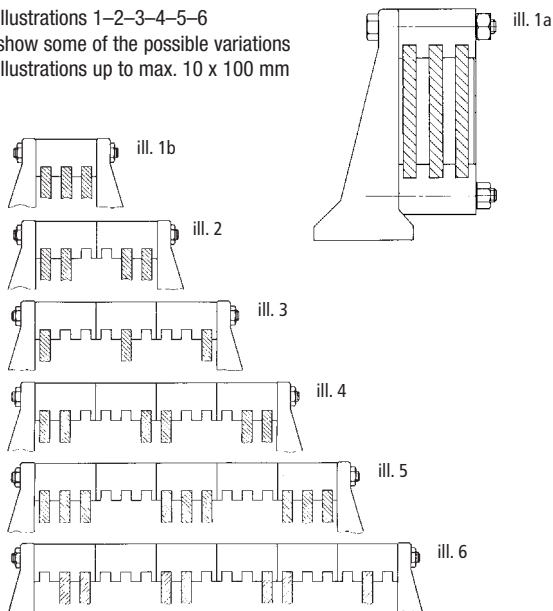
## Vertical bus bar support PSB

illustration 1  
example of a unipolar bus bar support with 3 parallel bus bar support holders



A = number of blocks  
B = bus bar thickness  
C = length of mounting screw  
L = external space requirement  
H = height  
M = module

Illustrations 1–2–3–4–5–6  
show some of the possible variations  
illustrations up to max. 10 x 100 mm



H. with lateral support PSB/1 = 177 mm  
PSB/2 = 127 mm  
M. with block PSB/6 = 36 mm  
PSB/8 = 48 mm  
PSB/10 = 60 mm

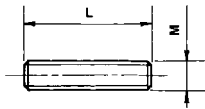
Art.-no.	Packaging-unit	Article group	Illustration	H (mm)	L (mm)	Operating voltage	For thread	B
90187		PSB	ill. 1A	177		1000	M10	6
90188		PSB	ill. 1A	177		1000	M10	8
90189		PSB	ill. 1A	177		1000	M10	10
90190		PSB	ill. 1B	177	162	1000	M10	6
90191		PSB	ill. 1B	177	174	1000	M10	8
90192		PSB	ill. 1B	177	186	1000	M10	10
90193		PSB	ill. 2	177	198	1000	M10	6
90194		PSB	ill. 2	177	222	1000	M10	8
90195		PSB	ill. 2	177	246	1000	M10	10
90196		PSB	ill. 3	177	234	1000	M10	6
90197		PSB	ill. 3	177	270	1000	M10	8
90198		PSB	ill. 3	177	306	1000	M10	10
90199		PSB	ill. 4	177	270	1000	M10	6
90200		PSB	ill. 4	177	318	1000	M10	8
90201		PSB	ill. 4	177	366	1000	M10	10
90202		PSB	ill. 5	177	306	1000	M10	6
90203		PSB	ill. 5	177	366	1000	M10	8
90204		PSB	ill. 5	177	426	1000	M10	10
90205		PSB	ill. 6	177	342	1000	M10	6
90206		PSB	ill. 6	177	414	1000	M10	8
90207		PSB	ill. 6	177	486	1000	M10	10
90211		PSB	ill. 1A	127		1000	M10	6
90212		PSB	ill. 1A	127		1000	M10	8
90213		PSB	ill. 1A	127		1000	M10	10
90214		PSB	ill. 1B	127	152	1000	M10	6
90215		PSB	ill. 1B	127	164	1000	M10	8
90216		PSB	ill. 1B	127	176	1000	M10	10
90217		PSB	ill. 2	127	188	1000	M10	6
90218		PSB	ill. 2	127	212	1000	M10	8
90219		PSB	ill. 2	127	236	1000	M10	10
90220		PSB	ill. 3	127	224	1000	M10	6
90221		PSB	ill. 3	127	260	1000	M10	8
90222		PSB	ill. 3	127	296	1000	M10	10
90223		PSB	ill. 4	127	260	1000	M10	6
90224		PSB	ill. 4	127	308	1000	M10	8
90225		PSB	ill. 4	127	356	1000	M10	10
90226		PSB	ill. 5	127	296	1000	M10	6
90227		PSB	ill. 5	127	356	1000	M10	8
90228		PSB	ill. 5	127	416	1000	M10	10
90229		PSB	ill. 6	127	332	1000	M10	6
90230		PSB	ill. 6	127	404	1000	M10	8
90231		PSB	ill. 6	127	476	1000	M10	10

The above mentioned data are only for information purposes and are without a guarantee. The customer is required to check from time to time if the product is suitable for the required application.

Upon request milled bus bar supports and other from GPO-3 extracted details can be supplied. In this instance drawings are to be submitted.

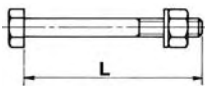
### Mounting materials / threaded bolts

**GB**  
threaded bolt



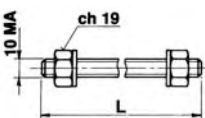
Art.-no.	Packaging-unit	Article group	Thread M	Length L (mm)
90270	100	GB	M3	12
90271	100	GB	M3	15
90272	100	GB	M4	15
90273	100	GB	M4	16
90274	100	GB	M4	18
90275	100	GB	M4	20
90276	100	GB	M5	20
90277	100	GB	M5	22
90278	100	GB	M5	27
90279	100	GB	M5	30
90280	100	GB	M6	18
90281	100	GB	M6	20
90282	100	GB	M6	25
90283	100	GB	M6	27
90284	100	GB	M6	33
90285	100	GB	M6	35
90286	100	GB	M8	20
90287	100	GB	M8	23
90288	100	GB	M8	25
90289	100	GB	M8	30
90290	100	GB	M8	33
90291	100	GB	M8	35
90292	100	GB	M8	38
90293	100	GB	M8	50
90294	100	GB	M10	30
90295	100	GB	M10	35
90296	100	GB	M10	38
90297	100	GB	M10	40
90298	100	GB	M10	45
90299	100	GB	M10	50
90300	100	GB	M12	30
90301	100	GB	M12	50
90326	100	GB	M16	40
90327	100	GB	M16	60

**hexagon screw**  
M10 with nut and washer



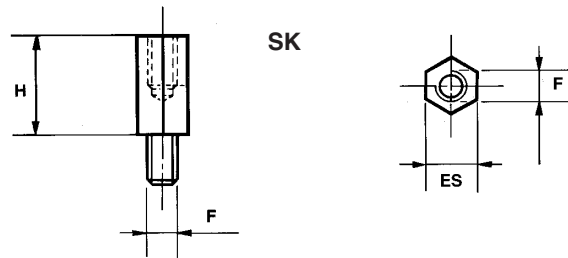
Art.-no.	Packaging-unit	Article group	Thread M	Length L (mm)
90309	100	SKS	M10	60
90310	100	SKS	M10	80
90311	100	SKS	M10	70
90312	100	SKS	M10	90
90313	100	SKS	M10	100
90314	100	SKS	M10	110
90315	100	SKS	M10	140
90316	100	SKS	M10	150
90317	100	SKS	M10	160

**threaded bolt**  
M10 complete with nut and washer



Art.-no.	Packaging-unit	Article group	Thread M	Length L (mm)
90318	100	GB	M10	194
90319	100	GB	M10	230
90320	100	GB	M10	242
90321	100	GB	M10	270
90322	100	GB	M10	290
90323	100	GB	M10	350
90324	100	GB	M10	410
90325	100	GB	M10	1000

### Hexagon spacers in brass



Art.-no.	Packaging-unit	Thread M	Height H mm	Wrench opening SW*
90330	100	M4	15	7
90331	100	M4	20	7
90332	100	M4	25	7
90333	100	M4	30	7
90334	100	M4	50	7
90335	100	M4	70	7
90336	100	M4	90	7
90337	100	M5	15	8
90338	100	M5	20	8
90339	100	M5	25	8
90340	100	M5	30	8
90341	100	M5	50	8
90342	100	M5	70	8
90343	100	M5	90	8
90344	100	M6	15	10
90345	100	M6	20	10
90346	100	M6	25	10
90347	100	M6	30	10
90348	100	M6	50	10
90349	100	M6	70	10
90350	100	M6	90	10
90351	100	M8	15	13
90352	100	M8	20	13
90353	100	M8	25	13
90354	100	M8	30	13
90355	100	M8	50	13
90356	100	M8	70	13
90357	100	M8	90	13

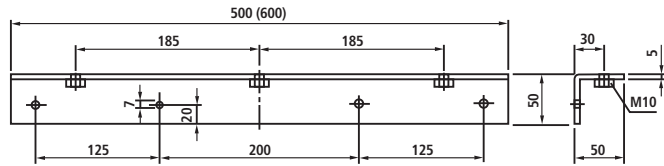
\* SW = Screw Width



## Bus bar support L

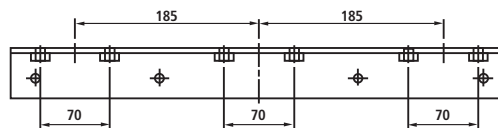
support L185/1

Art.-no. 90392



support L185/2 (2 x M10 each phase)

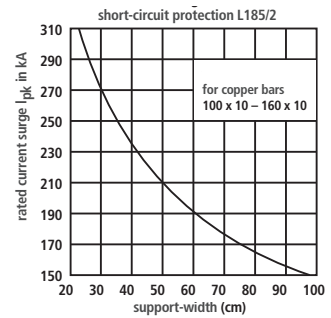
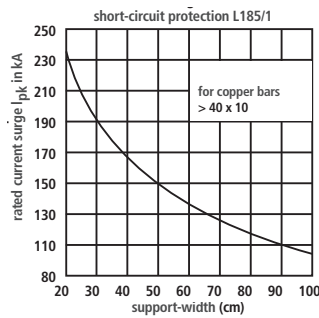
Art.-no. 90395



## Bus bar supports in general

### Characteristics of the raw materials (GFK-profile, hot hardened)

■ temperature range	-40 °C up to +130 °C
■ operating AC voltage	1000 Volt
■ continuous current	L/Z 280 mm 2500 A L/Z 500 mm 4000 A
■ phase clearance	L/Z 280 mm 100 mm L/Z 500 mm 185 mm
■ form stability	DIN 53462 °C > 200
■ natural density	DIN 53479 gr/cm <sup>2</sup> approx. 1.7
■ fire resistance	UL 94 HB
■ discharge resistance	DIN 53481 kV/cm 10
■ resistance voltage tracking	DIN IEC 112 CTI 600
■ specific flow resistance	DIN 53482 Ohm x cm 1012

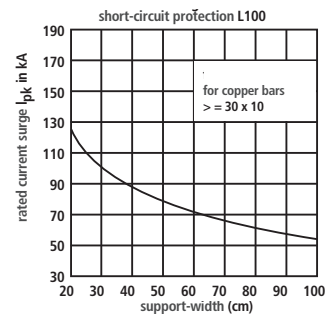
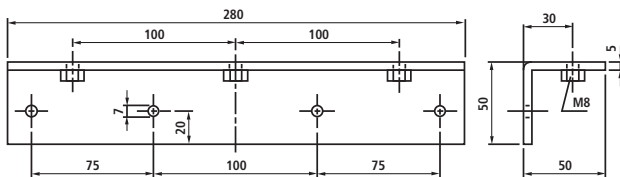


### All bus bars are type tested acc. to VDE 0660 part 500

- torque for M10 approx. 4.5 Nm
- copper bus bar 10 mm thick made of copper F30 not nickel-plated

support L100

Art.-no. 90392



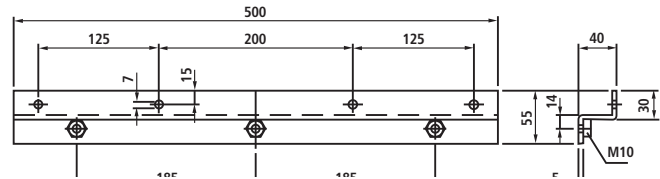
Type	Art.-no.	Packaging-unit	Article group	Length (mm)	Profile (mm)	Bore (mm)	Thread M	Colour
L100	90391	1	L	280	50/50	7	M8	■
L185/1	90392	1	L	500	50/50	7	M10	■
L185/2	90395	1	L	500	50/50	7	M10	■



### Bus bar support Z

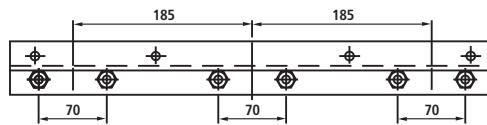
support Z185/1

Art.-no. 90382



support Z185/2 (2 x M10 each phase)

Art.-no. 90385



### Bus bar supports in general

#### Characteristics of the raw materials (GFK-profile, hot hardened)

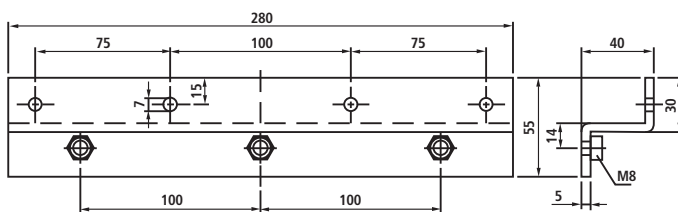
- temperature range -40 °C up to +130 °C
- operating AC voltage 1000 Volt
- continuous current
  - L/Z 280 mm 2500 A
  - L/Z 500 mm 4000 A
- phase clearance
  - L/Z 280 mm 100 mm
  - L/Z 500 mm 185 mm
- form stability DIN 53462 °C > 200
- natural density DIN 53479 gr/cm<sup>2</sup> approx.1.7
- fire resistance UL 94 HB
- discharge resistance DIN 53481 kV/cm 10
- resistance voltage tracking DIN IEC 112 CTI 600
- specific flow resistance DIN 53482 Ohm x cm 1012

#### All bus bars are type tested acc. to VDE 0660 part 500

- torque for M10 approx. 4.5 Nm
- copper bus bar 10 mm thick made of copper F30 not nickel-plated

support Z100

Art.-no. 90381



Type	Art.-no	Packaging-unit	Article group	Length (mm)	Profile (mm)	Bore (mm)	Thread M	Colour
Z100	90381	1	Z	280	30/40/30	7	M8	■
Z185/1	90382	1	Z	500	30/40/30	7	M10	■
Z185/2	90385	1	Z	500	30/40/30	7	M10	■



# Additional products

## Shunts

---

**Amperemeter change-over switch**

---

**Voltmeter change-over switch**

---

**NEOZED fuse base**

---

**Contact tongue**

---



# Shunts

**Technical data:**
**Operating conditions**

working temperature range	-10 ≤ θ ≤ + 55 °C
storage temperature	-25 ≤ θ ≤ + 65 °C
relative air humidity (no dewing)	≤ 75 %
climatic adaptability	climatic class 3 acc. VDE/VDI 3540

**Accuracy**

accuracy class	class 0.5 (class 0.2 upon request)
----------------	---------------------------------------

**Material**

resistance bars	manganin
connection units	
construction type A	brass
construction type B/C	copper

**Connections**

current phase	refer to drawings
voltage phase	M 5 x 8

**Dimensions**

refer to drawings

**Protection**

IP 00

**Material profile of the connection units**

construction type A	with isolating base (...25 A) without isolating base (30...150 A)
construction type B	L-profile
construction type C	T-profile

**Weight**

upon request

**Application**

Shunts are being used for the indirect monitoring of high electrical currents. The production of the shunts conform to the requirements of DIN 43704 for currents from 1 A up to 20 kA and voltage drops from 60 mV up to 300 mV. Upon request additional ranges can be supplied where the nominal values of current and voltage drop deviate from the DIN series.

**Function principle**

The current flowing through the shunts create a voltage drop, which can be measured with a measuring device switched in parallel. With parallel switching the shunts and the measuring devices, it is possible to use voltage measurement devices to measure the current, or to gain an extension of the measuring facilities of the existing current measuring units. The shunts are manufactured in three different versions, to accommodate the nominal currents.

**Production regulations**

DIN 43703	Shunts
DIN 43780	direct active, signalling measuring units and accessories

**Special configurations**

nominal rated voltage drop	acc. to customers information
nominal current	acc. to customers information
accuracy class	0.2
isolation base	for shunts 30...200 A/60 mV

Order details	
Type	Shunts
nominal rated voltage drop	60 mV 100 mV 150 mV 300 mV acc. to customers information**)
nominal current	see table in the data section page 225, 226, 227 acc. to customers information**)
Accuracy	class 0.5*) class 0.2 upon request
Isolation base	for construction type A standard bus bars snap-on mountings can be supplied 1...25 A standard 30...200 A (60 mV) accessories
Cap	1...25 A (60 mV; 100 mV; 150 mV) accessories 30...200 A (60 mV) accessories
Special configuration**)	upon request

\*) standard \*\*) exact data are required

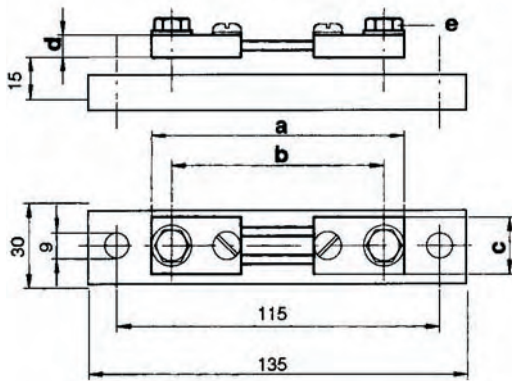
**Order example:**

shunt, nominal rated voltage drop 60 mV, nominal current 1000 A, class 0.5

technical amendments may be made without prior notice.

# Shunts

## Construction type A



Dimensions for 1...25 A

Nominal rated voltage drop 60 mV		
Size	1...25 A	40...150 A
a	90	100
b	78	80
c	20	20
d	8	8
e	M 5 x 12	M 8 x 16

Nominal rated voltage drop 100 mV		
Size	1...25 A	40...150 A
a	90	145
b	78	125
c	20	25
d	8	8
e	M 5 x 12	M 8 x 16

Nominal rated voltage drop 150 mV		
Size	1...25 A	40...150 A
a	90	225
b	78	205
c	20	25
d	8	8
e	M 5 x 12	M 8 x 16

Nominal rated voltage drop 300 mV		
Size	1...25 A	40...150 A
a	90	385
b	78	364
c	20	25
d	8	8
e	M 5 x 12	M 8 x 16

# Shunts

## Construction type A

Construction type A				
Art.-no.	Base	Type	Nominal current	Nominal voltage drop
71911	without	SHUNT 60	1 A	60 mV
71911S	with	SHUNT 60	1 A	60 mV
71912	without	SHUNT 60	1.5 A	60 mV
71912S	with	SHUNT 60	1.5 A	60 mV
71913	without	SHUNT 60	2.5 A	60 mV
71913S	with	SHUNT 60	2.5 A	60 mV
71914	without	SHUNT 60	4 A	60 mV
71914S	with	SHUNT 60	4 A	60 mV
71915	without	SHUNT 60	6 A	60 mV
71915S	with	SHUNT 60	6 A	60 mV
71916	without	SHUNT 60	10 A	60 mV
71916S	with	SHUNT 60	10 A	60 mV
71917	without	SHUNT 60	15 A	60 mV
71917S	with	SHUNT 60	15 A	60 mV
71918	without	SHUNT 60	25 A	60 mV
71918S	with	SHUNT 60	25 A	60 mV
71919	without	SHUNT 60	40 A	60 mV
71919S	with	SHUNT 60	40 A	60 mV
71920	without	SHUNT 60	60 A	60 mV
71920S	with	SHUNT 60	60 A	60 mV
71921	without	SHUNT 60	100 A	60 mV
71921S	with	SHUNT 60	100 A	60 mV
71922	without	SHUNT 60	150 A	60 mV
71922S	with	SHUNT 60	150 A	60 mV
72911	without	SHUNT 100	1 A	100 mV
72911S	with	SHUNT 100	1 A	100 mV
72912	without	SHUNT 100	1.5 A	100 mV
72912S	with	SHUNT 100	1.5 A	100 mV
72913	without	SHUNT 100	2.5 A	100 mV
72913S	with	SHUNT 100	2.5 A	100 mV
72914	without	SHUNT 100	4 A	100 mV
72914S	with	SHUNT 100	4 A	100 mV
72915	without	SHUNT 100	6 A	100 mV
72915S	with	SHUNT 100	6 A	100 mV
72916	without	SHUNT 100	10 A	100 mV
72916S	with	SHUNT 100	10 A	100 mV
72917	without	SHUNT 100	15 A	100 mV
72917S	with	SHUNT 100	15 A	100 mV
72918	without	SHUNT 100	25 A	100 mV
72918S	with	SHUNT 100	25 A	100 mV
72919	without	SHUNT 100	40 A	100 mV
72919S	with	SHUNT 100	40 A	100 mV
72920	without	SHUNT 100	60 A	100 mV
72920S	with	SHUNT 100	60 A	100 mV
72921	without	SHUNT 100	100 A	100 mV
72921S	with	SHUNT 100	100 A	100 mV
72922	without	SHUNT 100	150 A	100 mV
72922S	with	SHUNT 100	150 A	100 mV

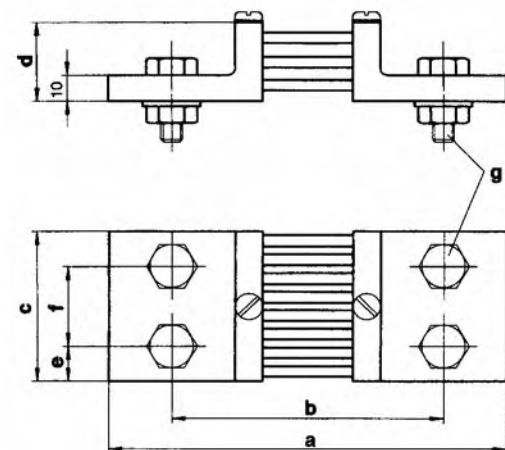
Construction type A				
Art.-no.	Base	Type	Nominal current	Nominal voltage drop
73911	without	SHUNT 150	1 A	150 mV
73911S	with	SHUNT 150	1 A	150 mV
73912	without	SHUNT 150	1.5 A	150 mV
73912S	with	SHUNT 150	1.5 A	150 mV
73913	without	SHUNT 150	2.5 A	150 mV
73913S	with	SHUNT 150	2.5 A	150 mV
73914	without	SHUNT 150	4 A	150 mV
73914S	with	SHUNT 150	4 A	150 mV
73915	without	SHUNT 150	6 A	150 mV
73915S	with	SHUNT 150	6 A	150 mV
73916	without	SHUNT 150	10 A	150 mV
73916S	with	SHUNT 150	10 A	150 mV
73917	without	SHUNT 150	15 A	150 mV
73917S	with	SHUNT 150	15 A	150 mV
73918	without	SHUNT 150	25 A	150 mV
73918S	with	SHUNT 150	25 A	150 mV
73919	without	SHUNT 150	40 A	150 mV
73919S	with	SHUNT 150	40 A	150 mV
73920	without	SHUNT 150	60 A	150 mV
73920S	with	SHUNT 150	60 A	150 mV
73921	without	SHUNT 150	100 A	150 mV
73921S	with	SHUNT 150	100 A	150 mV
73922	without	SHUNT 150	150 A	150 mV
73922S	with	SHUNT 150	150 A	150 mV
74911	without	SHUNT 300	1 A	300 mV
74911S	with	SHUNT 300	1 A	300 mV
74912	without	SHUNT 300	1.5 A	300 mV
74912S	with	SHUNT 300	1.5 A	300 mV
74913	without	SHUNT 300	2.5 A	300 mV
74913S	with	SHUNT 300	2.5 A	300 mV
74914	without	SHUNT 300	4 A	300 mV
74914S	with	SHUNT 300	4 A	300 mV
74915	without	SHUNT 300	6 A	300 mV
74915S	with	SHUNT 300	6 A	300 mV
74916	without	SHUNT 300	10 A	300 mV
74916S	with	SHUNT 300	10 A	300 mV
74917	without	SHUNT 300	15 A	300 mV
74917S	with	SHUNT 300	15 A	300 mV
74918	without	SHUNT 300	25 A	300 mV
74918S	with	SHUNT 300	25 A	300 mV
74919	without	SHUNT 300	40 A	300 mV
74919S	with	SHUNT 300	40 A	300 mV
74920	without	SHUNT 300	60 A	300 mV
74920S	with	SHUNT 300	60 A	300 mV
74921	without	SHUNT 300	100 A	300 mV
74921S	with	SHUNT 300	100 A	300 mV
74922	without	SHUNT 300	150 A	300 mV
74922S	with	SHUNT 300	150 A	300 mV

# Shunts

## Construction type B



Nominal rated voltage drop 60 mV					
Size	250 A	400 A 600 A	1000 A	1500 A	2500 A
a	145	145	165	165	165
b	105	105	115	115	115
c	30	40	60	90	120
d	30	30	30	30	30
e	15	20	30	21	30
f				48	60
g	M 12 x 40	M 16 x 45	M 20 x 50	M 16 x 45	M 20 x 50
no. of current connect.	2 x 1	2 x 1	2 x 1	2 x 2	2 x 2



Nominal rated voltage drop 100 mV					
Size	250 A	400 A 600 A	1000 A	1500 A	
a	190	190	210	210	
b	150	150	160	160	
c	30	40	60	120	
d	30	30	30	30	
e	15	20	30	30	
f				60	
g	M 12 x 40	M 16 x 45	M 20 x 50	M 20 x 50	
no. of current connect.	2 x 1	2 x 1	2 x 1	2 x 2	

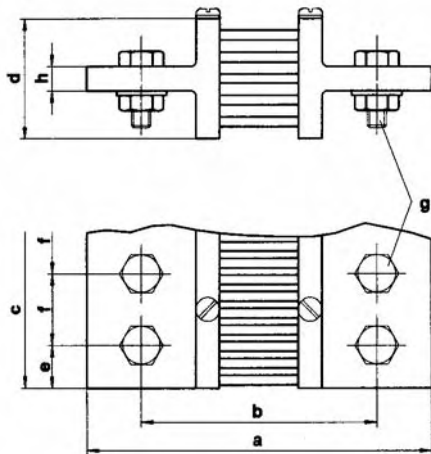
Construction type B				
Art.-no.	Base	Type	Nominal current	Nominal rated voltage drop
71923	without	SHUNT 60	250 A	60 mV
71924	without	SHUNT 60	400 A	60 mV
71925	without	SHUNT 60	600 A	60 mV
71926	without	SHUNT 60	1000 A	60 mV
71996	without	SHUNT 60	1500 A	60 mV
71997	without	SHUNT 60	2500 A	60 mV
72923	without	SHUNT 100	250 A	100 mV
72924	without	SHUNT 100	400 A	100 mV
72925	without	SHUNT 100	600 A	100 mV
72926	without	SHUNT 100	1000 A	100 mV
72935	without	SHUNT 100	1500 A	100 mV
73923	without	SHUNT 150	300 A	150 mV
73924	without	SHUNT 150	400 A	150 mV
73925	without	SHUNT 150	600 A	150 mV
73926	without	SHUNT 150	1000 A	150 mV
74923	without	SHUNT 300	250 A	300 mV
74924	without	SHUNT 300	400 A	300 mV
74925	without	SHUNT 300	600 A	300 mV
74926	without	SHUNT 300	1000 A	300 mV

Nominal rated voltage drop 150 mV					
Size	250 A	400 A 600 A	1000 A		
a	270	270	290		
b	230	230	240		
c	30	40	70		
d	50	50	60		
e	15	20	35		
g	M 12 x 40	M 16 x 45	M 20 x 50		
no. of current connect.	2 x 1	2 x 1	2 x 1		

Nominal rated voltage drop 300 mV					
Size	250 A	400 A 600 A	1000 A		
a	429	429	449		
b	389	389	399		
c	30	40	70		
d	50	50	60		
e	15	20	35		
g	M 12 x 40	M 16 x 45	M 20 x 50		
no. of current connect.	2 x 1	2 x 1	2 x 1		

# Shunts

## Construction type C



Nominal rated voltage drop 60 mV				
Size	4000 A	6000 A	10000 A	15000 A
a	165	175	185	185
b	115	125	135	135
c	120	154	206	310
d	60	130	170	170
e	30	25	25	25
f	60	52	52	52
g	M 20 x 60	M 20 x 75	M 20 x 80	M 20 x 80
h	15	25	30	30
no. of current connect.	2 x 2	2 x 3	2 x 4	2 x 6

Nominal rated voltage drop 100 mV				
Size	2500 A	4000 A	6000 A	
a	210	220	220	
b	160	170	170	
c	120	120	154	
d	60	130	130	
e	30	30	25	
f	60	60	52	
g	M 20 x 50	M 20 x 50	M 20 x 75	
h	15	25	25	
no. of current connect.	2 x 2	2 x 2	2 x 3	

Construction type C				
Art.-no.	Base	Type	Nominal current	Nominal rated voltage drop
71927 *	without	SHUNT 60	1500 A	60 mV
71928	without	SHUNT 60	2500 A	60 mV
71929	without	SHUNT 60	4000 A	60 mV
71930	without	SHUNT 60	6000 A	60 mV
71931	without	SHUNT 60	1000 A	60 mV
71932	without	SHUNT 60	1500 A	60 mV
72928	without	SHUNT 100	2500 A	100 mV
72929	without	SHUNT 100	4000 A	100 mV
72930	without	SHUNT 100	6000 A	100 mV
73927	without	SHUNT 150	1500 A	150 mV
73928	without	SHUNT 150	2500 A	150 mV
73929	without	SHUNT 150	4000 A	150 mV
73930	without	SHUNT 150	6000 A	150 mV
73931	without	SHUNT 150	10000 A	150 mV
74927	without	SHUNT 300	1500 A	300 mV
74928	without	SHUNT 300	2500 A	300 mV
74929	without	SHUNT 300	4000 A	300 mV
74930	without	SHUNT 300	6000 A	300 mV

Nominal rated voltage drop 150 mV					
Size	1500 A	2500 A	4000 A	6000 A	10000 A
a	290	290	300	300	310
b	240	240	250	250	260
c	90	120	120	154	206
d	60	60	130	130	170
e	21	30	30	25	25
f	48	60	60	52	52
g	M 16 x 60	M 20 x 60	M 20 x 75	M 20 x 75	M 20 x 80
h	15	15	25	25	30
no. of current connect.	2 x 1	2 x 1	2 x 2	2 x 3	2 x 4

Nominal rated voltage drop 300 mV				
Size	1500 A	2500 A	4000 A	6000 A
a	449	449	459	459
b	399	399	409	409
c	90	120	120	154
d	60	60	130	130
e	31	30	30	25
f	48	60	60	52
g	M 16 x 60	M 20 x 60	M 20 x 75	M 20 x 75
h	15	15	25	25
no. of current connect.	2 x 1	2 x 2	2 x 2	2 x 3

\* special configuration

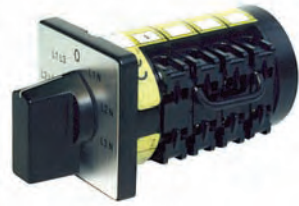
# Additional products

## Amperemeter change-over switch



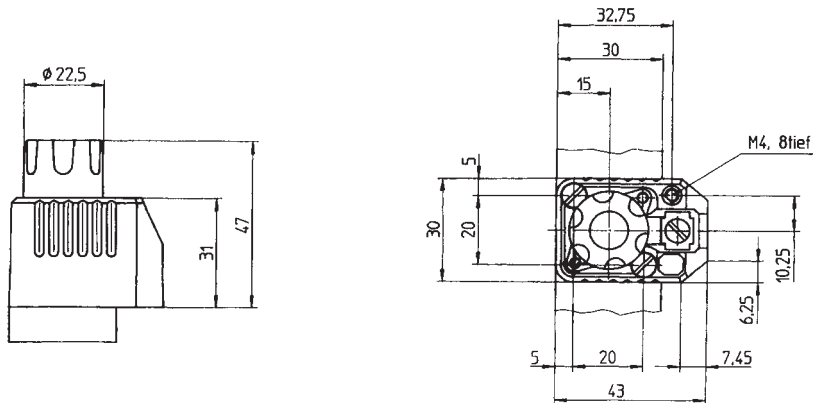
Amperemeter change-over switch		
		Art.-no.
amperemeter change-over switch	with 0-position	59061
amperemeter change-over switch	without 0-position	59062

## Voltmeter change-over switch



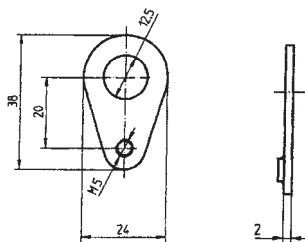
Voltmeter change-over switch		
		Art.-no.
voltmeter change-over switch	with 0-position	59060
voltmeter change-over switch	without 0-position	59063

## NEOZED fuse base



NEOZED fuse base		
		Art.-no.
fuse base 10 A		59011

## Contact tongue



Contact tongue				
	Length	Depth	Width	Art.-no.
thread M5	38	2	24	59055



# Voltage transformers

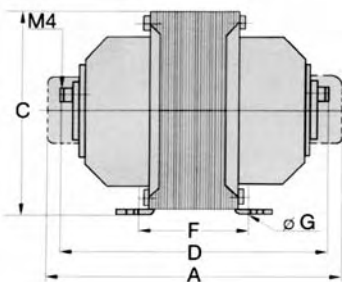
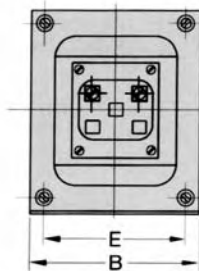
## 1-pole isolated



Rated voltage	Secondary rated voltage 100 V / $\sqrt{3}$ V				
Type	MBEV 6	MBEV 10	MBEV 20	MBEV 50	MBEV 100
Accuracy class	1	0.5 / 1	0.5 / 1	0.5 / 1	0.5 / 1
Burden	VA 3	VA 5/10	VA 10/20	VA 25/50	VA 50/100
Primary V	Art.-no.	Art.-no.	Art.-no.	Art.-no.	Art.-no.
100/ $\sqrt{3}$	SEV1001	SEV1010	SEV1019	SE V1028	SEV1037
110/ $\sqrt{3}$	SEV1002	SEV1011	SEV1020	SEV1029	SEV1038
220/ $\sqrt{3}$	SEV1003	SEV1012	SEV1021	SEV1030	SEV1039
380/ $\sqrt{3}$	SEV1004	SEV1013	SEV1022	SEV1031	SEV1040
400/ $\sqrt{3}$	SEV1005	SEV1014	SEV1023	SEV1032	SEV1041
500/ $\sqrt{3}$	SEV1006	SEV1015	SEV1024	SEV1033	SEV1042
600/ $\sqrt{3}$	SEV1007	SEV1016	SEV1025	SEV1034	SEV1043
800/ $\sqrt{3}$			SEV1026	SEV1035	SEV1044
1000/ $\sqrt{3}$			SEV1027	SEV1036	SEV1045

## 2-pole isolated

Rated voltage	Secondary rated voltage 100 V				
Type	MBZV 6	MBZV 10	MBZV 20	MBZV 50	MBZV 100
Accuracy class	1	0.5 / 1	0.5 / 1	0.5 / 1	0.5 / 1
Burden	VA 6	VA 10/20	VA 20/40	VA 50/100	VA 100/200
Primary V	Art.-no.	Art.-no.	Art.-no.	Art.-no.	Art.-no.
100	SZV1001	SZV1010	SZV1019	SZ V1028	SZV1037
110	SZV1002	SZV1011	SZV1020	SZV1029	SZV1038
220	SZV1003	SZV1012	SZV1021	SZV1030	SZV1039
380	SZV1004	SZV1013	SZV1022	SZV1031	SZV1040
400	SZV1005	SZV1014	SZV1023	SZV1032	SZV1041
500	SZV1006	SZV1015	SZV1024	SZV1033	SZV1042
600	SZV1007	SZV1016	SZV1025	SZV1034	SZV1043
800			SZV1026	SZV1035	SZV1044
1000			SZV1027	SZV1036	SZV1045



Technical data of the standard design	
standard	IEC 60044-2
max. voltage for equipment	0.72 kV up to 600 V - 1.2 kV up to 1000 V
test voltage	0.72 kV / 3 kV; 1 kV / 6 kV
rated frequency	50 / 60 Hz
place of application	indoors up to 2000 m above normal sea level
climatic conditions	IEC 60721-3-3 3K4
mechanical conditions	IEC 60721-3-3 3M3
vibration proof	IEC 60068-2 2.5 g (25...100 Hz)
isolating class	IEC 60085 E (120 °C)
housing protection class	IEC 60529 housing: IP 50 terminals with cover: IP 20
isolating material	UL E44423 copper coated wire UL E47960 winding contacts UL E93687 isolation coating UL E51047 imprinted coating

Type	Housing in mm							Weight kg	Standard accessories
	A	B	C	D	E	F	Ø G		
MBEV 6	140	85	100	125	68	52	4.5	2.3	terminal covers
MBEV 10	165	90	105	145	70	67	4.5	3	
MBEV 20	175	90	105	155	70	82	4.5	4.1	
MBEV 50	195	105	125	175	81	95	5.5	6	
MBEV 100	210	128	155	190	101	97	8	8	
MBZV 6	140	85	100	125	68	52	4.5	2.3	terminal covers
MBZV 10	165	90	105	145	70	67	4.5	3	
MBZV 20	175	90	105	155	70	82	4.5	4.1	
MBZV 50	195	105	125	175	81	95	5.5	6	
MBZV 100	210	128	155	190	101	97	8	8	

# Voltage transformers

## 1-pole isolated

Rated voltage Primary V	Type	Size	Secondary rated voltage 100 V / $\sqrt{3}$ V								P <sub>i</sub> VA	L <sub>2th</sub> A
			Accuracy class									
			0.2		0.5		1		3			
VA	Art.-no.	VA	Art.-no.	VA	Art.-no.	VA	Art.-no.	VA	Art.-no.			
100 / $\sqrt{3}$ 110 / $\sqrt{3}$ 200 / $\sqrt{3}$ 220 / $\sqrt{3}$ 230 / $\sqrt{3}$ corresponding isolation level	MBER 60	2	-	-	-	-	0.5	SE1001	1.5	SE1002	0.3	0.6
	MBER 70		0.2	SE1003	0.5	SE1004	1	SE1005	3	SE1006	0.6	0.8
	MBER 100		1	SE1007	2.5	SE1008	5	SE1009	15	SE1010	1.5	1.2
	MBER 104		5	SE1011	15	SE1012	30	SE1013	30	SE1014	2	0.9
	MBE 100		-	-	10	SE1015	15	SE1016	50	SE1017	5	1
	MBE 150	1	7.5	SE1018	20	SE1019	50	SE1020	120	SE1021	10	3
	MBE 150	2	10	SE1022	30	SE1023	60	SE1024	150	SE1025	12	3
	MBE 150	3	15	SE1026	50	SE1027	100	SE1028	200	SE1029	15	3
	MBE 150	4	25	SE1030	60	SE1031	120	SE1032	250	SE1033	20	3
380 / $\sqrt{3}$ . 400 / $\sqrt{3}$ 500 / $\sqrt{3}$ . 600 / $\sqrt{3}$ 660 / $\sqrt{3}$ corresponding isolation level	MBER 100		0.5	SE1034	1.5	SE1035	3	SE1036	10	SE1037	1.5	1.2
	MBER 104		5	SE1038	10	SE1039	25	SE1040	25	SE1041	2	0.9
	MBE 100		-	-	10	SE1042	15	SE1043	50	SE1044	5	1
	MBE 150	1	7.5	SE1045	20	SE1046	50	SE1047	120	SE1048	10	3
	MBE 150	2	10	SE1049	30	SE1050	60	SE1051	150	SE1052	12	3
	MBE 150	3	15	SE1053	50	SE1054	100	SE1055	200	SE1056	15	3
	MBE 150	4	25	SE1057	60	SE1058	120	SE1059	250	SE1060	20	3
690 / $\sqrt{3}$ 750 / $\sqrt{3}$ 1000 / $\sqrt{3}$ corresponding isolation level U <sub>M</sub> = 1.2 kV	MBER 100/1		-	-	1	SE1061	2	SE1062	5	SE1063	1.5	1.2
	MBER 104/1		5	SE1064	10	SE1065	25	SE1066	25	SE1067	2	0.9
	MBE 100/1		-	-	7.5	SE1068	15	SE1069	30	SE1070	5	1
	MBE 150/1	1	7.5	SE1071	20	SE1072	45	SE1073	100	SE1074	10	3
	MBE 150/1	2	10	SE1075	30	SE1076	60	SE1077	120	SE1078	12	3
	MBE 150/1	3	15	SE1079	45	SE1080	90	SE1081	150	SE1082	15	3
	MBE 150/1	4	20	SE1083	60	SE1084	100	SE1085	180	SE1086	20	3

additional charges for special configurations

Auxiliary winding for production of an open delta winding (VA rating of measuring winding reduced by approx. 30 %): ... /  $\sqrt{3}$  / ... /  $\sqrt{3}$  / 100 /  $\sqrt{3}$  V

Type	Size	Long time current
MBE 150	-	1 A / 8 h

Type	Size	Long time current
MBE 100	-	1 A / 8 h
MBE 150	1	5 A / 8 h
MBE 150	2	6 A / 8 h
MBE 150	3	8 A / 8 h

Intermediate voltage transformer for production of an open delta winding (without measuring winding):  
100 /  $\sqrt{3}$  / 100 /  $\sqrt{3}$  V

Type	Tropical design	Resin hardened
MBE (Z) R 60		
MBE (Z) R 70		
MBE (Z) R 100 (/1)		
MBE (Z) R 104 (/1)		
MBE (Z) 100 (/1)		-
MBE (Z) 150 (/1)		-

snap-on mountings for:

Type	
MBE (Z) R 60	
MBE (Z) R 70	

joint foot mounting for:

Type	
MBE (Z) R 70	

additional special configurations upon request

see page 234

# Voltage transformers

## 2-pole isolated

Rated voltage Primary V	Type	Size	Secondary rated voltage 100 V								P <sub>i</sub> VA	L <sub>2th</sub> A
			Accuracy class									
			0.2		0.5		1		3			
VA	Art.-no.	VA	Art.-no.	VA	Art.-no.	VA	Art.-no.	VA	Art.-no.			
100, 110, 200, 220, 230  corresponding isolation level U <sub>M</sub> = 0.72 kV	MBZR 60	2	-	-	0.5	SZ1001	1	SZ1002	3	SZ1003	0.5	0.4
	MBZR 70		1	SZ1004	2.5	SZ1005	5	SZ1006	15	SZ1007	2	0.5
	MBZR 100		2	SZ1008	5	SZ1009	10	SZ1010	25	SZ1011	2.5	0.8
	MBZR 104		5	SZ1012	15	SZ1013	30	SZ1014	30	SZ1015	3	0.9
	MBZ 100		-	-	15	SZ1016	30	SZ1017	60	SZ1018	9	1
	MBZ 150	1	10	SZ1019	25	SZ1020	60	SZ1021	150	SZ1022	12	3
	MBZ 150	2	15	SZ1023	45	SZ1024	90	SZ1025	200	SZ1026	15	3
	MBZ 150	3	20	SZ1027	60	SZ1028	120	SZ1029	250	SZ1030	18	3
	MBZ 150	4	30	SZ1031	75	SZ1032	150	SZ1033	300	SZ1034	24	3
380, 400, 500, 600, 660  corresponding isolation level U <sub>M</sub> = 0.72 kV	MBZR 60	2	-	-	*	*	1	SZ1035	3	SZ1036	0.5	0.4
	MBZR 70		0.5	SZ1037	1.25	SZ1038	2.5	SZ1039	7.5	SZ1040	1.5	0.5
	MBZR 100		1.5	SZ1041	3	SZ1042	10	SZ1043	20	SZ1044	2	0.8
	MBZR 104		5	SZ1045	10	SZ1046	25	SZ1047	25	SZ1048	2.5	0.9
	MBZ 100		-	-	15	SZ1049	30	SZ1050	60	SZ1051	9	1
	MBZ 150	1	10	SZ1052	25	SZ1053	60	SZ1054	150	SZ1055	12	3
	MBZ 150	2	15	SZ1056	45	SZ1057	90	SZ1058	200	SZ1059	15	3
	MBZ 150	3	20	SZ1060	60	SZ1061	120	SZ1062	250	SZ1063	18	3
	MBZ 150	4	30	SZ1064	75	SZ1065	150	SZ1066	300	SZ1067	24	3
690, 750, 1000  corresponding isolation level U <sub>M</sub> = 1.2 kV	MBZR 60/1	2	-	-	*	*	*	*	*	*	0.5	0.4
	MBZR 70/1		*	*	*	*	*	*	*	*	1.5	0.5
	MBZR 100/1		1	SZ1068	2.5	SZ1069	5	SZ1070	15	SZ1071	1.5	0.8
	MBZR 104/1		5	SZ1072	10	SZ1073	25	SZ1074	25	SZ1075	2.5	0.9
	MBZ 100/1		-	-	7.5	SZ1076	15	SZ1077	30	SZ1078	9	0.8
	MBZ 150/1	1	7.5	SZ1079	20	SZ1080	50	SZ1081	120	SZ1082	12	2
	MBZ 150/1	2	10	SZ1083	30	SZ1084	60	SZ1085	150	SZ1086	15	2
	MBZ 150/1	3	15	SZ1087	45	SZ1088	100	SZ1089	200	SZ1090	18	2
	MBZ 150/1	4	20	SZ1091	60	SZ1092	120	SZ1093	250	SZ1094	24	2

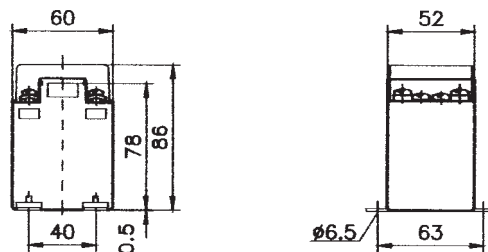
\* upon request

Technical data of the standard design		
standard	IEC 60044-2 DIN VDE 0414 T.2	
max. voltage for equipment	U <sub>m</sub> 0.72 kV MBE... MBZ... (U <sub>m</sub> 1.2 kV) MBE.../1. MBZ.../1	
test voltage	3 kV. 50 Hz. 1 min (6 kV. 50 Hz. 1 min)	
rated frequency	50...60 Hz	
place of application	indoors up to 2000 m above normal sea level	
climatic conditions	IEC 721	3K4
mechanical conditions	IEC 721	3K3
vibration proof	IEC 68-2	2.5 g (25...100 Hz)
isolating class	DIN IEC 85 VDE 0301-1	E 120 °C
housing protection class	IEC EN 60529 DIN VDE 0470	housing: IP 50 terminals with cover: IP 20

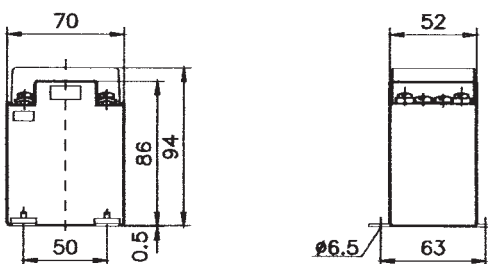
# Voltage transformers

Type	Size	Housing in mm				Weight kg	Standard accessories
		Width	Height	Depth	H		
MBZR 60 (/1)	2	60	78	52		0.5	foot mounting terminal covers
MBZR 70 (/1)		70	86	52		0.6	
MBZR 100 (/1)		100	118	73		1.1	
MBZR 104 (/1)		104	127	75		2.0	
MBZ 100 (/1)		102	105	111		3.1	
MBZ 150 (/1)	1	150	123	142	40	7.0	
MBZ 150 (/1)	2	150	123	152	50	8.0	
MBZ 150 (/1)	3	150	123	162	60	9.0	
MBZ 150 (/1)	4	150	123	182	80	11.5	

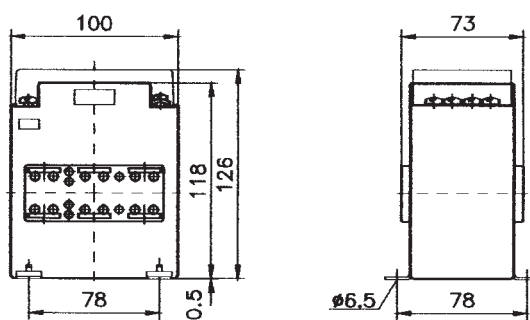
MBZR 60 (/1)  
(MBER 60)



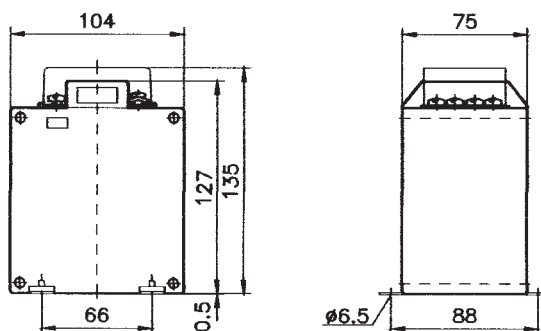
MBZR 70 (/1)  
(MBER 70)



MBZR 100 (/1)  
(MBER 100)



MBZR 104 (/1)  
[MBER 104 (/1)]



**Order example**

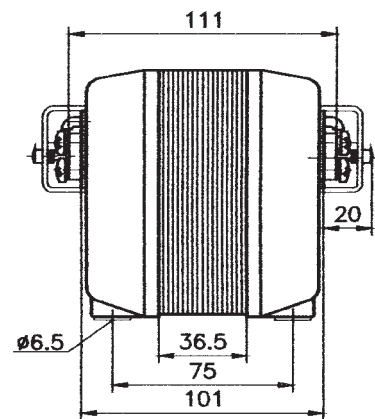
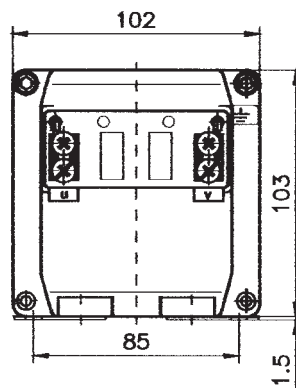
type: **MBZR 60**  
 rated measuring ratio: **200/100 V**  
 rated burden: **0.5 VA**  
 accuracy class: **0.5**  
 art.-no.: **SZ1001-200**

# Voltage transformers

Type	Size	Housing in mm				Weight kg	Standard accessories
		Width	Height	Depth	H		
MBER 60 (/1)	2	60	78	52		0.5	foot mounting terminal covers
MBER 70 (/1)		70	86	52		0.6	
MBER 100 (/1)		100	118	73		1.1	
MBER 104 (/1)		104	127	75		2.0	
MBE 100 (/1)		102	105	111		3.1	
MBE 150 (/1)	1	150	123	142	40	7.0	
MBE 150 (/1)	2	150	123	152	50	8.0	
MBE 150 (/1)	3	150	123	162	60	9.0	
MBE 150 (/1)	4	150	123	182	80	11.5	

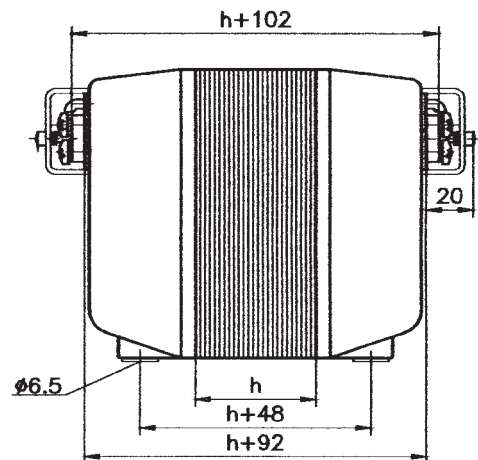
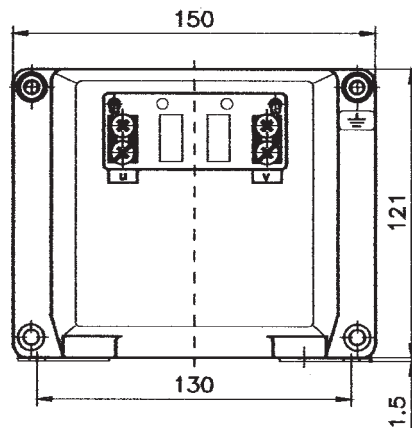
MBER 60, MBER 70, MBER 100(/1), MBER 104 (/1) drawings see page 235

MBE 100 (/1)  
[MBZ 100 (/1)]



MBE 150 (/1)  
[MBZ 150 (/1)]

size 1 – size 4



**Order example**

type	<b>MBE 100/1</b>
rated measuring ratio	<b>750/√3/100/√3</b>
rated burden	<b>15 VA</b>
accuracy class	<b>1</b>
art.-no.	<b>SE1069-750</b>

## Measuring transducers for all electrical AC-variables

Order List

		page	page
<b>SWMUP</b>	Measuring transducer for AC with integrated current transformerD . . . . .	.238	
<b>NMC</b>	Clip-on measuring transducers for MBS current transformers . . . . .	.241	
<b>NMC-AD</b>	Adaptors for current transformers of any make . . . . .	.243	
<b>NMC-KSx</b>	Short circuit adaptors . . . . .	.243	
<b>FASK</b>	Flexible clip-on current transformers (Rogowski coil) . . . . .	.244	272
	<b>EMBSIN</b> . . . . .	.246	
<b>EMBSIN 100 IV</b>	Measuring transducers for AC current, without auxiliary voltage supply . . . . .	.248	273
<b>EMBSIN 100 I</b>	Measuring transducers for AC current, without auxiliary voltage supply . . . . .	.249	273
<b>EMBSIN 101 I</b>	Measuring transducers for AC current, with auxiliary voltage supply . . . . .	.250	274
<b>EMBSIN 201 IEV</b>	Measuring transducers for AC current, rms measurement . . . . .	.251	275
<b>EMBSIN 201 IE</b>	Measuring transducers for AC current, rms measurement . . . . .	.252	277
<b>EMBSIN 120 UV</b>	Measuring transducers for AC voltage, without auxiliary voltage supply . . . . .	.253	278
<b>EMBSIN 120 U</b>	Measuring transducers for AC voltage, without auxiliary voltage supply . . . . .	.254	278
<b>EMBSIN 121 U</b>	Measuring transducers for AC voltage, with auxiliary voltage supply . . . . .	.255	274
<b>EMBSIN 221 UEV</b>	Measuring transducers for AC voltage, rms measurement . . . . .	.256	275
<b>EMBSIN 221 UE</b>	Measuring transducers for AC voltage, rms measurement . . . . .	.257	277
<b>EMBSIN 241 FV</b>	Measuring transducers for frequency, with auxiliary voltage supply . . . . .	.258	279
<b>EMBSIN 241 F</b>	Measuring transducers for frequency with universal AC/DC power supply . . . . .	.259	280
<b>EMBSIN 241 FD</b>	Measuring transducers for frequency difference, with universal AC/DC power supply . . . . .	.260	280
<b>EMBSIN 271 G</b>	Measuring transducers for phase angle, with universal AC/DC power supply . . . . .	.261	281
<b>EMBSIN 271 GD</b>	Measuring transducers for phase angle difference, with universal AC/DC power supply . . . . .	.262	283
<b>EMBSIN 281 G</b>	Measuring transducers for power factor, with universal AC/DC power supply . . . . .	.263	281
<b>EMBSIN 351 P</b>	Measuring transducers for active power, with universal AC/DC power supply . . . . .	.264	284
<b>EMBSIN 361 Q</b>	Measuring transducers for re-active power, with universal AC/DC power supply . . . . .	.265	284
<b>EMBSIN 301</b>	Programmable measuring transducers for AC current, rms measurement . . . . .	.266	285
<b>EMBSIN 391 PV</b>	Programmable measuring transducers for all electrical variables . . . . .	.267	285
<b>EMBSIN 391</b>	Programmable measuring transducers for electrical AC variables . . . . .	.270	



SWMU



NMC



FASK



EMBSIN

# SWMU

## Measuring transducer for alternating current



The above photo of an SWMU 41.51 denotes a bus bar. This bus bar is not included in the supply of the unit.

- with or without auxiliary voltage supply
- with integrated current transformer housing unit
- for 35 mm DIN rail

### Features/benefits

- measuring input: Sinus-shaped AC current (1 A ... 800 A),
- arithmetical mean value measurement, effective value calibrated
- measuring output: Unipolar output signal
- measurement principle: Rectifier process
- with integrated current transformer
- minimal wiring

### Application

Measuring transducers for the transformation of sinus-shaped AC current. For an output signal a load-independent DC current / and an imprinted DC voltage signal is available, which stands proportionally to the measurement value of the input volume.

These signals can be used for display, recording, monitoring and/or control function.

The measuring transducer fulfills the requirements and regulations with regard to the electromagnetic compatibility (EMV) and security (IEC 1010 and EN 61010). This measuring transducer has been designed, produced, and tested in accordance with ISO 9001.

### Technical data SWMU 41.51/52 SWMU 42.51/52

<b>measuring input</b> $\oplus$		<b>auxiliary power</b> $\rightarrow \circ$	
nominal frequency	$f_N$ 50/60 Hz	AC power supply	230 V $\pm$ 10 % (50 ... 60 Hz)
rated input current $I_N$		DC	24 V $\pm$ 15 %
SWMU 41.52	1 ... 10 A	power input	$\leq$ 1.5 W (2.5 VA)
SWMU 41.51	15 ... 800 A	<b>accuracy</b>	
consumption	$\leq$ 1 VA (2.5 VA without auxiliary voltage)	reference value	output end value
overload capacity	1.5 · $I_N$ , constant 8 · $I_N$ , 40 sec.	accuracy class	class 0.5
<b>measuring output</b> $\rightarrow$		warming-up time	$\leq$ 5 min.
load-independent DC current	0 ... 20 mA or 4 ... 20 mA*	<b>protection</b>	
max. burden resistance	$\leq$ 500 $\Omega$	electrocution protection	IP 40, housing (test wire, EN 60529) IP 20, connection terminals (test digit, EN 60529)
max. burden voltage	$\leq$ 15 V	contamination class	2
current limit		test voltages	4 kV, activ circuits against housing (DIN 57411) 4 kV, auxiliary voltage against measuring output (230 V-version) 500 V, auxiliary voltage against measuring output (24 V-DC-version)
under overload	$\leq$ 34 mA		
imprinted DC voltage	0 ... 10 V or 2 ... 10 V*		
burden resistance	$\geq$ 10 k $\Omega$		
max. burden voltage			
under overload	$\leq$ 18 V		
voltage limit	$\leq$ 18 V		
residual ripple			
of the output current	$\leq$ 1 % p.p.		
response time	$\leq$ 500 ms		
operating temperature range	-5 °C $\leq$ $\vartheta$ $\leq$ +40 °C		

\*Live-Zero only with auxiliary voltage

**1. Auxiliary voltage 230 V AC**

Type SWMU	Primary current A	Measuring output			
		0...20 mA and 0... 10 V	4...20 mA and 0... 10 V	0...20 mA and 2... 10 V	4...20 mA and 2... 10 V
41.52	1	61006	62006	63006	64006
	5	61007	62007	63007	64007
	10	61008	62008	63008	64008
	special*	61100	62100	63100	64100
41.51	15	61009	62009	63009	64009
	20	61010	62010	63010	64010
	25	61011	62011	63011	64011
	30	61012	62012	63012	64012
	40	61013	62013	63013	64013
	50	61014	62014	63014	64014
	60	61015	62015	63015	64015
	75	61016	62016	63016	64016
	100	61017	62017	63017	64017
	150	61018	62018	63018	64018
	200	61019	62019	63019	64019
	250	61020	62020	63020	64020
	300	61021	62021	63021	64021
	400	61022	62022	63022	64022
	500	61023	62023	63023	64023
	600	61024	62024	63024	64024
	750	61025	62025	63025	64025
800	61026	62026	63026	64026	
special*	61200	62200	63200	64200	

measuring frequency 50/60 Hz

weight 350 g

\* measuring range defined by customer

**2. Auxiliary voltage 24 V DC**

Type SWMU	Primary current A	Measuring output			
		0...20 mA and 0... 10 V	4...20 mA and 0... 10 V	0...20 mA and 2... 10 V	4...20 mA and 2... 10 V
41.52	1	65006	66006	67006	68006
	5	65007	66007	67007	68007
	10	65008	66008	67008	68008
	special*	65100	66100	67100	68100
41.51	15	65009	66009	67009	68009
	20	65010	66010	67010	68010
	25	65011	66011	67011	68011
	30	65012	66012	67012	68012
	40	65013	66013	67013	68013
	50	65014	66014	67014	68014
	60	65015	66015	67015	68015
	75	65016	66016	67016	68016
	100	65017	66017	67017	68017
	150	65018	66018	67018	68018
	200	65019	66019	67019	68019
	250	65020	66020	67020	68020
	300	65021	66021	67021	68021
	400	65022	66022	67022	68022
	500	65023	66023	67023	68023
	600	65024	66024	67024	68024
	750	65025	66025	67025	68025
800	65026	66026	67026	68026	
special*	65200	66200	67200	68200	

measuring frequency 50/60 Hz

weight 250 g

\* measuring range defined by customer


**3. Without auxiliary voltage supply**

Type SWMU	Primary current A	Measuring output
		0... 20 mA and 0... 10 V
42.52	1	69006
	5	69007
	special*	69100
42.51	40	69013
	50	69014
	60	69015
	75	69016
	100	69017
	150	69018
	200	69019
	250	69020
	300	69021
	400	69022
	500	69023
	600	69024
	750	69025
	800	69026
special*	69200	

 power requirements  $P_E \geq 2.5 \text{ VA}$  !

measuring frequency 50/60 Hz

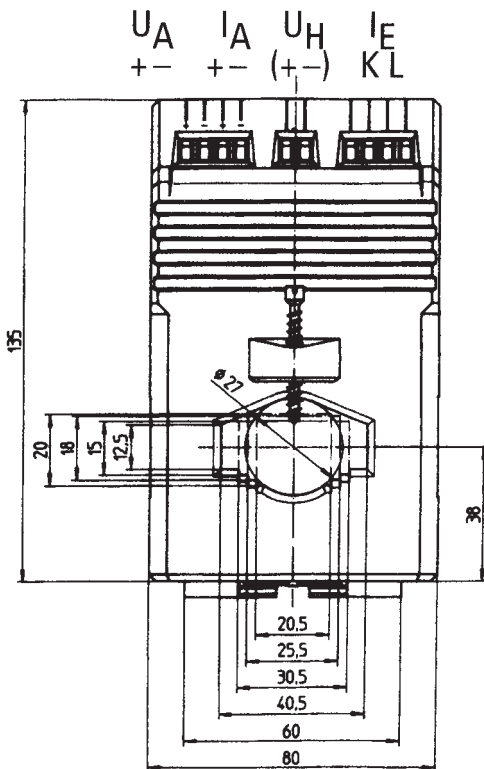
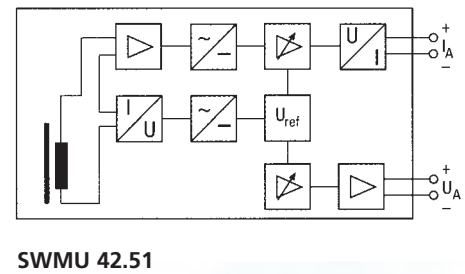
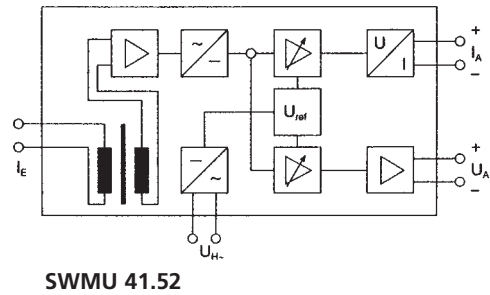
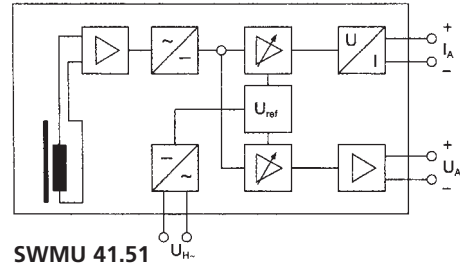
weight 600 g

 operating range 15...120 %  $I_N$ 

\* measuring range defined by customer



Basic circuit diagrams



depth 50 (72) mm



mounting base for direct fitting without use of a 35 mm DIN rail (included in the delivery content)



# NMC

## Measuring transducer for AC currents

### Clip-on measuring transducer for MBS current transformers in modular construction, versions with (NMC 2/3/4) or without auxiliary voltage supply (NMC-0)

#### Features/benefits

- measuring input: Sinus-shaped AC current (1 A or 5 A)  
arithmetical mean value measurement, effective value calibrated
- measuring output: Unipolar output signal
- measurement principle: Rectifier process
- direct notching with MBS current transformers through contact studs
- economic wiring

#### Application

Measuring transducers for the transformation of sinus-shaped AC current. For an output signal a load-independent DC current and an imprinted DC voltage signal is available, which stands proportionally to the measurement value of the input volume. These signals can be used for display, recording, monitoring and or control function.

Simultaneously, the secondary current of the current transformers can be utilised to operate conventional needle instruments .

The measuring transducer fulfills the requirements and regulations with regard to the electromagnetic compatibility (EMV) and security (IEC 1010 and EN 61010). This measuring transducer has been designed, produced, and tested in accordance with ISO 9001.

#### Technical data NMC 0/2/3/4

<b>measuring input</b> $\oplus$		<b>auxiliary power</b> $\rightarrow \circ$	
nominal frequency $f_N$	50/60 Hz	AC power supply	230 V $\pm 10$ % (50 ... 60 Hz) or 110 V $\pm 10$ % (50 ... 60 Hz)
rated input current $I_N$	1 A or 5 A	DC	24 V $\pm 15$ %
power input	$\leq 1$ VA	power input	$\leq 1.5$ W (2.5 VA)
from measuring circuit	<b>(2.5 VA w/o auxiliary voltage)</b>	<b>accuracy</b>	
overload capacity	1.2 $I_N$ , constant 8 · $I_N$ , <40 sec.	reference value	output end value
<b>measuring output</b> $\rightarrow$		accuracy class	class 0.5
load-independent DC current	0 ... 20 mA or 4 ... 20 mA	accuracy range	NMC 2/3/4 1 ... 120 % $I_N$ NMC 0 15 ... 120 % $I_N$
max. burden resistance	500 $\Omega$	warming-up time	$\leq 5$ min.
max. burden voltage	$\leq 15$ V	<b>protection</b>	
current limit		electrocution protection	IP 40, housing (test wire, EN 60529) IP 20, connection terminals (test digit, EN 60529)
under overload	$\leq 34$ mA	contamination class	2
imprinted DC voltage	0 ... 10 V or 2 ... 10 V*	test voltages	4 kV, activ circuits against housing (DIN 57411) 4 kV, auxiliary voltage against measurement outputs (230 V AC-version) 500 V, auxiliary voltage against measurement output (24 V DC-version)
min. burden resistance	$\geq 10$ k $\Omega$		
max. burden voltage			
under overload	$\leq 18$ V		
residual ripple			
of the output current	$\leq 1$ % p.p.		
response time	< 500 ms		

\*Live-Zero only with auxiliary voltage

NMC measuring transducer for sinus-shaped alternating currents, for clip-on to MBS current transformer (rectifier-mean value measurement)

Auxiliary voltage 24 V DC galvanically separated

Type NMC (2)	Measuring outputs			Rated input current [A]	Suitable for current transformers in the product range
	0...20 mA and 0... 10 V	4...20 mA and 0... 10 V	4...20 mA and 2... 10 V		
211	39212	39232	39252	1	A
212	39213	39233	39253	1	B
213	39214	39234	39254	1	C
214	39215	39235	39255	1	D
221	39012	39032	39052	5	A
222	39013	39033	39053	5	B
223	39014	39034	39054	5	C
224	39015	39035	39055	5	D

measuring frequency 50/60 Hz; weight: 80 g; operating range 0 ... 120 % I<sub>N</sub>

Auxiliary voltage 230 V AC galvanically separated

Type NMC (3)	Measuring outputs			Rated input current [A]	Suitable for current transformers in the product range
	0...20 mA and 0... 10 V	4...20 mA and 0... 10 V	4...20 mA and 2... 10 V		
311	36212	36232	36252	1	A
312	36213	36233	36253	1	B
313	36214	36234	36254	1	C
314	36215	36235	36255	1	D
321	36041	36032	36052	5	A
322	36042	36033	36053	5	B
323	36043	36034	36054	5	C
324	36044	36035	36055	5	D

measuring frequency 50/60 Hz; weight: 80 g; operating range 0 ... 120 % I<sub>N</sub>

Auxiliary voltage 110 V AC galvanically separated

Type NMC (4)	Measuring outputs			Rated input current [A]	Suitable for current transformers in the product range
	0...20 mA and 0... 10 V	4...20 mA and 0... 10 V	4...20 mA and 2... 10 V		
411	76212	76232	76252	1	A
412	76213	76233	76253	1	B
413	76214	76234	76254	1	C
414	76215	76235	76255	1	D
421	76012	76032	76052	5	A
422	76013	76033	76053	5	B
423	76014	76034	76054	5	C
424	76015	76035	76055	5	D

measuring frequency 50/60 Hz; weight: 80 g; operating range 0 ... 120 % I<sub>N</sub>

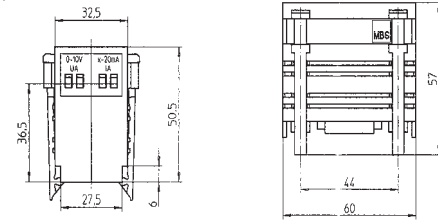
Without auxiliary voltage supply, power requirements ≥ 2.5 VA

Type NMC (0)	Measuring outputs			Rated input current [A]	Suitable for current transformers in the product range
	0...20 mA and 0... 10 V				
011	37212			1	A
012	37213			1	B
013	37214			1	C
014	37215			1	D
021	37012			5	A
022	37013			5	B
023	37014			5	C
024	37015			5	D

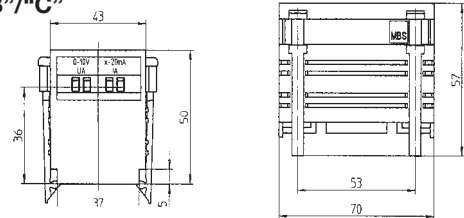
measuring frequency 50/60 Hz; weight: 80 g; operating range 15 ... 120 % I<sub>N</sub>

drawings

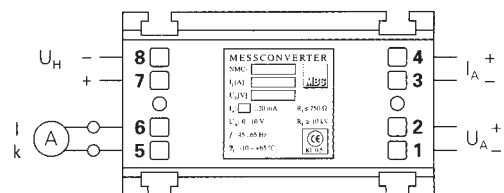
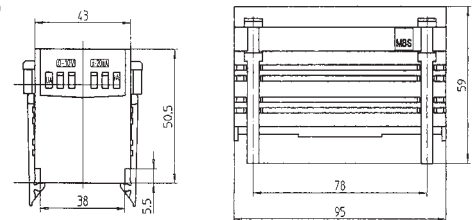
“A”



“B”/“C”



“D”



**Comment:** The dimensions of the measuring transducer are relevant only for the adaption to the existing current transformer construction types. All units consist of the same electronic modules.

# NMC selection chart

Primary current A	Construction type			
	A	B	C	D
1				
5				
10		WSK 30		
15			WSK 40	
20				
25				
30				
40				
50				
60				
75				
80				
100				
125				
150				
200	ASK 41.3	ASK 318.3	ASK 31.3	ASK 22.3
250				ASK 21.3
300	sec. 1			
400	up to			
500	300 A			
600				
750				
800				
1000				
1200				
1250				
1500				
1600				
2000				
2500				
3000				

## NMC-AD

Adaptor for current transformers of any make to clip-on to 35 mm DIN rail

### Features/benefits

- accommodation of any make of current transformer in connection with transducers of type NMC
- direct mounting of measuring transducers, in visual deviation to the measuring point, onto an approved 35 mm DIN rail



Order instruction	Application with NMC art.-no.
36011	39xx2; 36xx1/2; 37xx2; 76xx2

weight: 70 g

Connection	Description
6, 7	incoming terminals 5 A or 1 A (sourced from current transformers)

## Short circuit adaptor NMC-KSx



### Application

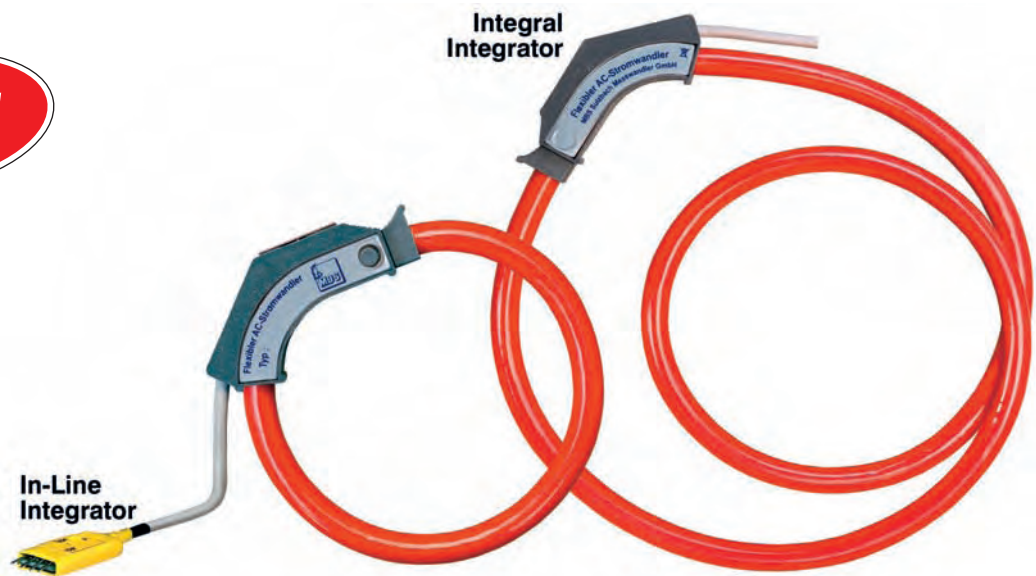
Adaptors of type NMC-KSx are clipped onto current transformers. When the secondary circuit of a current transformer is not being energized the adaptors prevent idling of the transformer, and thus the occurrence of high neutral voltages in the nominal current of the current transformer.

Type NMC-KSx	Art.-no.	Applicable with MBS current transformer types												Drawing	
		WSK 30	WSK 40	ASR 22.3	ASK 21.3	ASK 31.3	ASK 41.3	ASK 41.4	ASK 421.4	ASK 61.4	ASK 63.4	ASK 81.4	ASK 101.4		ASK 105.6
0	39090	•		•	•	•	•								A
1	39091		•												B
2	39092							•	•						C
3	39093									•	•	•	•	•	D

# Plug-in current transformer with flexible measuring system

FASK Flexible Clip-On Current Transformers

**New**



**Measuring principle:**

Rogowski Coil with or without integral integrator/amplifier

**Application:**

The FASK current transformer is manufactured to cover a wide range of lengths, current ranges and output levels to standard or OEM specifications.

Very low phase errors with true rms voltage output from the integrator enable the FASK Transformer to be used in a wide variety of current or kW/kWh measurement applications.

Compared with the conventional iron cored CT, the FASK has minimal weight and is narrow enough to clip on to all types of phase conductors even in very tight and crowded cubicles. Mounting hardware is not required, FASK is simple to secure in position using cable ties.



These CT's were the first to offer a hybrid integrator/buffer amplifier embedded in the clip assembly. This is digitally calibrated to provide a high linearity output characteristic. The absence of an iron core means that the FASK displays no hysteresis, iron loss or turns ratio errors. The FASK cannot magnetically saturate, there is no shock or damage hazard on open circuit. The low voltage output signal can be routed up to 25 m. to a meter, portable instrument, energy logger or BMS outstation, without any loss of accuracy.

The FASK is a high accuracy CT particularly with the conductor centrally positioned within the measurement coil. Its linearity provides a wide dynamic range, this enables accuracy to be maintained at the same level from the maximum current rating to around a 5 % of this rating.

# Plug-in current transformer with flexible measuring system

## FASK Flexible Clip-On Current Transformers

### Standard product availability

FASK production range, external power source 5 V, 9 V, 12 V, 24 V DC						
Standard type	F302	F305	F4010	F6020	F7530	F10030
length [cm]	30	30	40	60	75	100
Current range Ip. [A]	200	500	1000	2000	3000	3000
Min. recommended Amps	10	20	20	40	50	50
Coil diameter closed [mm]	75	75	110	160	200	300
Rectangular coil [mm]	20 x 85	30 x 120	30 x 120	60 x 200	60 x 250	60 x 400
Maximum loops	1	1	1	2	3	3/4

Output Voltage	Integral Integrator	In-line pod integrator			No Integrator
Full Scale output, Suffix	/05=500 mV AC	/1=1 V AC	/2=2 V AC	/3=3 V AC	0.21 mV/A
External power source	5 V DC reg	5 V DC reg	9 V DC	12 V DC	without

### Non-standard options

Any standard lengths (above) can be calibrated to any current range (in normal 100 A steps).  
Output sensitivities selectable from 100–3000 mV AC FSD for any CT (note required power source).

### Construction characteristics:

Mouldings:	HIPS Plastics, IP40 Protection, Pollution degree PD2
Winding/Coil former	Dual helical winding 330 turns/25 mm on HPDF flexible former
Sleeve material	PVC double insulation, wear indicator to IEC61010-1, Cat 3/600 V. Colour Red. Special colours subject to minimum quantity order
Coil sheath diameter	11 mm, plug width 14 mm
Isolation test voltage	3.5 kV, 6.5 kV peak 1,2/50 $\mu$ s, IEC61010-2-032 Type B transducer
Bend radius	30 mm minimum: number of loops see table above
Operating temp.	-20 °C to +85 °C, Humidity 0–95 % non condensing
Weight inc. 2 m lead	Fxx 30–120 g ----- Fxx 100–250 g.

<b>Measuring characteristics</b>	At 25 °C. PF 0.7–1.0, 50/60 Hz between 10 % & 100 % of Ip
Current range	100 A – 3000 A Standard range, 10 kA – 100 kA extended range
Frequency range	Coil plus integrator: 25 Hz–5 kHz +/-2dB Max, typ.-1dB.
Accuracy	+/-3 % FS Ip. +/-1.5 % of reading FS Ip to >10 % Ip.
Phase shift	Max 1 °, typical < 0.5 °.
External Field	Full rejection adjacent bus > 1 x diameter away., conductor centralised
Output AC voltage	True rms value. Full scale value selectable, see table above
Output DC option	4–20 mA DC (2 wire), 0–1 V DC, 0–5 V DC (3 wire) for current/ kVA applications

<b>External Power Source</b>	Integrator supply normally derived from host meter/instrument
Voltage	5 V DC regulated, 9, 12, 24 V DC unregulated.
Current	Typical 0.75–1.0 mA
Output leads	Red = + V supply, Yellow = Signal, Blue = 0 V Screen ground
Lead/cord length	2 m standard, extendable to 15 m

# EMBSIN

Measuring transducers for electrical variables



**MBS's measuring transducers of the type EMBSIN transforms an input alternating voltage and/or an input alternating current, received as a standard signal from a current transformer, – or voltage transformer, or from the power system, into a load imprinted output voltage.**

The various EMBSIN units are arranged to collate all measuring variables, which are necessary to monitor and to control, the power supply and consumption, to display the output signals, or to accept these into other units of the measuring- and control technic.

Several units such as indicators, recorders or signal processing systems can be connected to the output. The transducer's configuration assures a safe deviation for all functions for a galvanic separation between inputs and outputs. The most important applications for the transducers are in the generation and distribution of energy, in the manufacturing industry, and panel building enterprises.

The transducers have been developed upon an entirely new housing technology concept and are available in 5 different sizes.

The housing material made of high quality polycarbonate are **free of silicon as well as halogen** and, are flame resistant. High quality screw terminals are provided for the safe connections of inputs and outputs. Fitment onto the base wall is made with a 35 mm DIN rail. All electrical connections are made at the top of the units for safe and easy access.

The transducers bear the CE symbol. This symbol provides the highest level of protection for humans, the machine, as well as the environment, and of course, comply with all applicable safety regulations. MBS's production of high current measuring transducers, made of the finest quality enjoy a long tradition and a distinguished world wide reputation. The encapsulated housing design, the carefully chosen material and the construction principles, contribute that the measuring transducers are protected against climatic conditions (temperature and humidity), atmospheric conditions (chemical processes, dust and salt), vibration and shocks, interruptions (electrical or mechanical), HF interferences (communications) as well as permanent or transient interference voltages on all electrical connections.

• Compact • Safety • Easy to use • Accurate • Better

**Safety**

EN 61010 also on the terminals!  
 690 V max. input voltage  
 housing material: Polycarbonate  
 fire resistance class: V-0 acc. to UL94  
 (self-extinguishing, halogen-free, silicon-free)

**Easy to use**

Units with two wide-and auxiliary power ranges  
 24 ... 65 V AC/DC or 85 ... 230 V AC/DC auxiliary  
 power, to be connected either on the top or on the bot-  
 tom  $\cos \varphi$  or linear recalibrating/ can be synchronized  
 without opening the unit and without AC calibrators!  
 mounting onto 35 mm DIN rail  
 operating instructions are included

**Compact**

height 75 mm, V-series  
 height 60 mm  
 depth 105 mm, V-series  
 depth 112 mm  
 width 45 mm, V-series  
 width 105 mm for power,  
 70 mm for frequency and phase as well as  
 U and I with wide-range auxiliary  
 power  
 35 mm two-wire feed 24 V DC or 230 V AC  
 35 mm for current and voltage without  
 auxiliary power supply  
 100 mm EMBSIN 391 PV

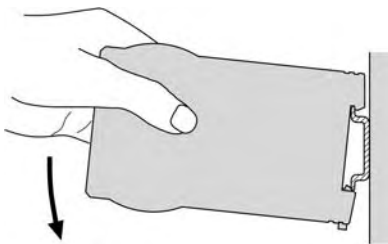
**Accuracy**

All units class 0.5  
 EMBSIN 241 FV class 0.2  
 EMBSIN 241 F class 0.2  
 EMBSIN 241 FD class 0.2

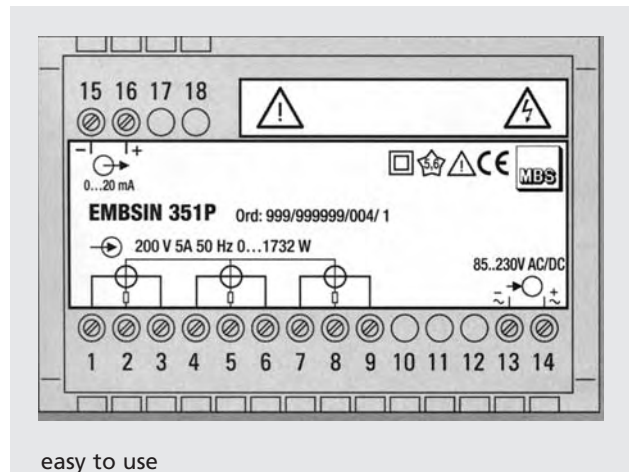
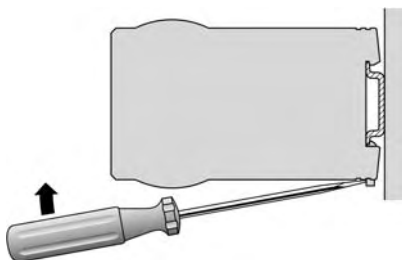
**Better**

Highest quality and safety at very competitive prices

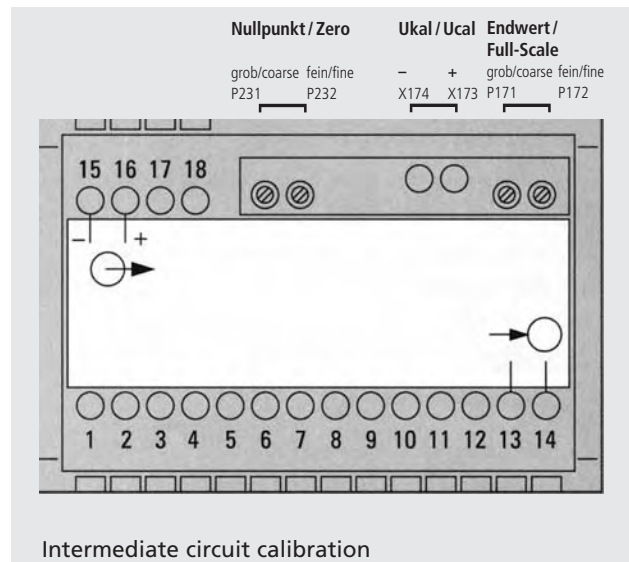
assembly



dismantling



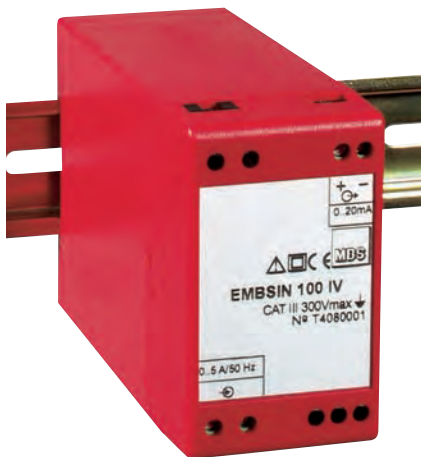
easy to use



Intermediate circuit calibration

# EMBSIN 100 IV

Measuring transducers for AC current



- without auxiliary voltage supply
- housing for 35 mm DIN rail mounting

### Features/benefits

- measuring input: Sinus-shaped alternating current (0...1 or 0...5 A) programmable at source
- measuring output: Unipolar output signal
- measuring principle: Rectifier mean value measurement process
- without auxiliary voltage supply
- economic consumption

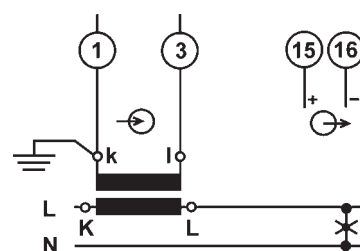
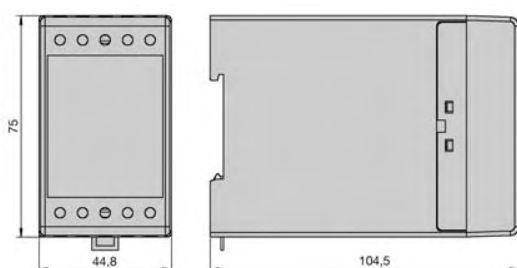
### Application

Measuring transducer for the proportional transformation of sinus-shaped alternating currents into a load-independent DC signal. The output signal is adjustable for analogue and digital units.

### Technical data EMBSIN 100 IV

<b>measuring input</b>		<b>connection conditions</b>	
rated frequency $f_N$	50/60 Hz	low voltage application	feed by means of a low voltage current transformer
rated input current $I_N$	0...1 bis 0...7.5 A	high voltage application	feed by means of a high voltage current transformer
consumption	$\leq 2$ VA	<b>connection terminals</b>	$\leq 4.0$ mm <sup>2</sup> solid wire $\leq 2.5$ mm <sup>2</sup> litze fine wire
overload capacity	$1.2 \cdot I_N$ , constant $20 \cdot I_N$ , 1 sec.	<b>safety</b>	
<b>measuring output</b>		protection class	II, (protection isolated, DIN EN 61010)
load-independent	0...5, 0...10 or	nominal isolation voltage	300 V, rms, connection category III 500 V, rms, connection category II
DC current $I_{ON}$	0...20 mA	test voltage	3.7 kV, rms in acc. with EN 61010-1:1990
burden voltage	$\leq 15$ V	electrocution protection	IP 40, housing (test wire, EN 60529) IP 20, connection terminals (test digit, EN 60529)
burden resistance	$R_{Bmax} = \frac{15V}{I_{ON} [mA]}$ k $\Omega$	<b>weight</b>	$\leq 250$ g
residual ripple			
of the output current	$\leq 1$ % p.p.		
response time	$\leq 300$ ms		
<b>accuracy</b>			
reference value	output end value		
accuracy class	class 0.5		
measuring range	0...100 %		
<b>reference conditions</b>			
ambient temperature	15...30 °C		
input signal	0...100 %		
frequency	45...65 Hz		

Order information see page 273



# EMBSIN 100 I

Measuring transducers for AC current



- without auxiliary voltage supply
- with 2 measuring ranges
- housing for 35 mm DIN rail mounting

### Features/benefits

- measuring input: Sinus-shaped alternating current (0...1/5 A or 0...1.2/6 A, selectable at terminals), arithmetical mean value measurement, effective value calibration
- measuring output: Output signal unipolar
- measuring principle: Rectifier mean value measurement process
- without auxiliary voltage supply
- economic consumption

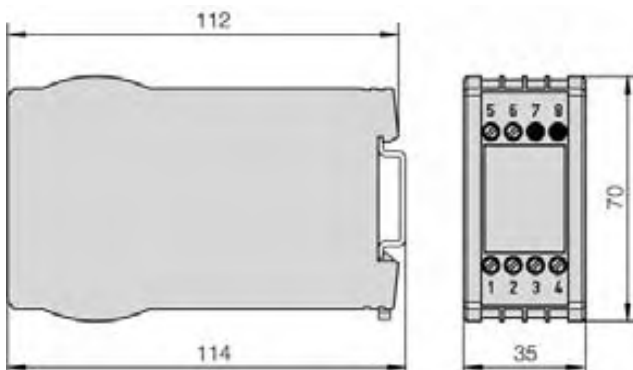
### Application

Measuring transducer for the transformation of sinus-shaped alternating current. A load-independent DC signal which is proportional to the measurement value serves as an output signal, and allows for display, recording, monitoring and/or control functions. This measuring transducer fulfills the requirements and regulations with regard to the electromagnetic compatibility (EMV) and safety (IEC 1010 and EN 61010).

### Technical data EMBSIN 100 I

<b>measuring input</b> →		<b>accuracy</b> →	
rated frequency $f_N$	50/60 Hz	reference value	output end value
rated input current $I_N$	1/5 A or 1.2/6 A, selectable	accuracy class	class 0.5
consumption	≤ 2.5 VA	input	0 ... 100 %
overload capacity	1.2 · $I_N$ , constant, 20 · $I_N$ , 1 sec.	temperature influence (-10 ... + 55 °C)	0.2 % / 10 K
<b>measuring output</b> →		<b>safety</b>	
load-independent	0 ... 5, 0 ... 10 or	protection class	II, (protection isolated, DIN EN 61010)
DC current	0 ... 20 mA	electrocution protection	IP 40, housing (test wire, EN 60529) IP 20, connection terminals (test digit, EN 60529)
burden voltage	≤ 15 V	contamination class	2
voltage limit		overvoltage category	III
by $R_{ext} = \infty$	≤ 30 V	nominal isolation	250 V input
current limit		voltage (to earth)	40 V output
under overload	≤ 34 mA	<b>weight</b>	270 g
residual ripple			
of the output current	≤ 1 % p.p.		
response time	≤ 300 ms		

Order information see page 273





# EMBSIN 101 I

Measuring transducers for AC current

- with auxiliary voltage supply optional with measuring output 4...20 mA and / or 2-wire technic
- housing for 35 mm DIN rail mounting

### Features/benefits

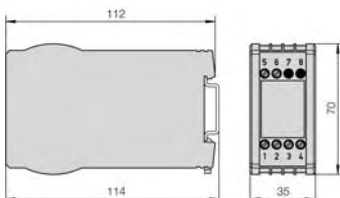
- measuring input: Sinus-shaped alternating current, arithmetical mean value measurement, effective value calibration
- measuring output: Unipolar and live-zero output signals
- measuring principle: Rectifier mean value measurement process
- AC or DC auxiliary power supply

### Application

Measuring transducer for the transformation of sinus-shaped alternating current. A load-independent DC signal or imprinted DC voltage signal is available, which stands proportionally to the measurement value of the input volume. This measuring transducer fulfills the requirements and regulations with regard to the electromagnetic compatibility (EMV) and safety (IEC 1010 and EN 61010).

### Technical data EMBSIN 101 I

<b>measuring input</b> $\rightarrow$		<b>auxiliary power</b> $\rightarrow$	
rated frequency $f_N$	50/60 Hz	AC	24, 110, 115, 120, 230 or 400 V, $\pm 15\%$ , 50 or 60 Hz; $P_v$ approx. 3 VA
rated input current $I_N$	0 ... 0.8 to 0 ... 1.2 A or 0 ... 4 to 0 ... 6 A	DC	24 V, - 15 / + 33 % or 24 V, - 50 / + 33 % by 2-wire feed and output 4 ... 20 mA; $P_v$ approx. 1.5 W
consumption	$\leq 5$ mV $I_N$	universal power supply ranges	DC or AC 40 ... 400 Hz 85 ... 230 V 24 ... 60 V
overload capacity	$2 \cdot I_N$ , constant	<b>accuracy</b>	
<b>measuring output</b> $\rightarrow$		reference value	output end value
load-independent DC current	0 ... 2.5 mA to 0 ... 20 mA or live-zero 1 ... 5 to 4 ... 20 mA	accuracy class	class 0.5
burden voltage	$\leq 15$ V	<b>safety</b>	
by 2-wire connection	standard range 4 ... 20 mA, external resistance $R_{ext}$ , dependent of the auxiliary supply H (12 ... 32 V DC) $R_{ext\ max} [k\Omega] = \frac{H [V] - 12 V}{20\ mA}$	protection class	II, (protection isolated, DIN EN 61010)
imprinted DC voltage	0 ... 5 to 0 ... 10 V or live-zero 1 ... 5 to 2 ... 10 V	electrocution protection	IP 40, housing (test wire, EN 60529), IP 20 connection terminals (test digit, EN 60529)
load capacity	max. 20 mA	contamination class	2
voltage limit by $R_{ext} = \infty$	$\leq 40$ V	overvoltage category	III
current limit under overload	< 30 mA by current output approx. 20 mA by voltage output	nominal isolation voltage (to earth)	300 V, input 300 V, auxiliary power AC 50 V, auxiliary power 24 V DC 50 V, output
residual ripple of the output current	$\leq 1\%$ p.p.	<b>weight</b>	195 g
response time	< 300 ms		



Order information see page 274

# EMBSIN 201 IEV

Measuring transducers for AC current



- with auxiliary voltage supply
- housing for 35 mm DIN rail mounting

**Features/benefits**

- measuring input: Sinus-shaped alternating current (0...6 A)
- measuring of the true rms value of alternating currents!
- programmable measuring inputs and measuring outputs via RS232 or RS485 interface (option)
- low consumption
- universal AC/DC auxiliary voltage supply or AC auxiliary voltage

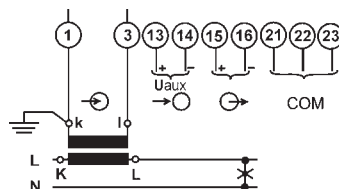
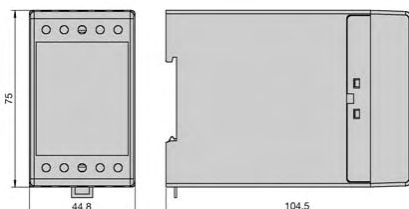
**Application**

Measuring transducer for the proportional transformation of sinus-shaped alternating currents into a load-independent DC current signal or AC voltage signal. The analogue output signal is proportionable to the true rms value of the measuring variables and can be used for regulating analogue and digital units.

**Technical data EMBSIN 201 IEV**

measuring input		accuracy	
rated frequency $f_N$	50/60 Hz	reference value	end value of input signal
Rated input current $I_N$	0...0.2 A to 0...6 A	accuracy class	class 0.5
own consumption	< 0,5 VA	<b>reference conditions</b>	
operating temperature range	-10 °C ≤ $\vartheta$ ≤ +55 °C	ambient temperature	15...30 °C
overload capacity	2 · $I_N$ , constant 20 · $I_N$ , 1 sec.	input signal	0...100 % $I_N$
		frequency	45...65 Hz
measuring output		protection	
load-independent DC current	0 ... 1 to 0 ... 20 mA or live-zero 0.2 ... 1 to 4 ... 20 mA	protection class	II 300 V, rms, connection category III 500 V, rms, connection category II
burden voltage	≤ 15 V	contamination class	2
imprinted DC voltage	0 ... 1 to 0 ... 10 V or live-zero 0.2 ... 1 bis 2 ... 10 V	test voltage	3 kV, rms (acc. IEC 61010-1: 1990)
load capacity	max. 20 mA	electrocution protection	IP 40, housing (test wire, EN 60529) IP 20, connection terminals (test digit, EN 60529)
output signal limit		<b>interface</b>	RS232, MODBUS RTU (optional) RS485, MODBUS RTU
current output	125 % $I_{AN}$	connection terminals	≤ 4.0 mm <sup>2</sup> solid wire ≤ 2.5 mm <sup>2</sup> Litze fine wire
voltage output	125 % $U_{AN}$	<b>weight</b>	approx. 300 g
residual ripple			
of the output current	≤ 1 % p.p.		
response time	< 300 ms		
auxiliary power			
universal power supply	DC or AC 40...70 Hz universal		
voltage ranges	24 ... 300 V DC and 40 ... 276 V AC		
AC power supply	45 ... 65 Hz		
rated voltages:	57,74 V, 100 V, 230 V, 400 V, 500 V		
power input	≤ 3 VA		

Order information see page 275



	RS232	
	9-pole plug (SUB-D)	25-pole plug
Rx (21)	Tx (3)	Tx (2)
± (22)	GND (5)	GND (7)
Tx (23)	Rx (2)	Rx (3)
RS485		
A (21)	DATA +	
C (22)	NC <sup>1)</sup>	
B (23)	DATA -	

1) -NC- do not connect!

# EMBSIN 201 IE

Measuring transducers for AC current



- with auxiliary voltage supply
- effective value measuring
- with 2 measuring ranges
- housing for 35 mm DIN rail mounting

**Features/benefits**

- measuring input: Sinus-shaped alternating current (0...1/5 A or 0...1.2/6 A, selectable at terminals), or distorted, effective value measuring
- measuring output: Unipolar and live-zero output signals
- measuring principle: Logarithmical process
- universal power supply

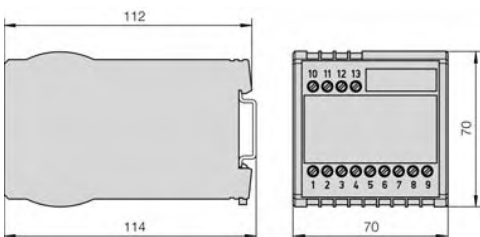
**Application**

Measuring transducer for the transformation of sinus-shaped or distorted alternating currents. A load-independent DC current signal or imprinted DC voltage signal is available, which is proportionally arranged to the rms input volume. The measuring transducer fulfills the requirements and regulations with regard to the electromagnetic compatibility (EMV) and safety (IEC 1010 or EN 61010).

**Technical data EMBSIN 201 IE**

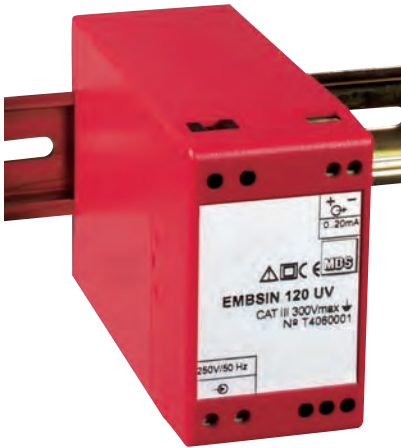
<b>measuring input</b> $\oplus$		<b>auxiliary power</b> $\oplus$	
rated frequency $f_N$	50/60 or 400 Hz	universal power supply	DC or 40 ... 400 Hz
rated input current $I_N$	1/5 A or 1.2/6 A, selectable	AC / DC ranges	24 ... 60 V or 85 ... 230 V
consumption	$\leq 1$ VA	AC power supply	45 ... 65 Hz
operating temperature range	$-10^\circ\text{C} \leq \vartheta \leq +55^\circ\text{C}$	power input	$\leq 1.5$ W (3 VA)
overload capacity	$1.2 \cdot I_N$ , constant $20 \cdot I_N$ , 1 sec.	<b>accuracy</b>	
<b>measuring output</b> $\ominus$		reference value	output end value
load-independent DC current	0 ... 1 to 0 ... 20 mA or live-zero 0.2 ... 1 to 4 ... 20 mA	accuracy class	class 0.5
burden voltage	$\leq 15$ V	peak value factor	$\sqrt{2}$
external resistance	$R_{Bmax} = \frac{15\text{V}}{I_{AN}[\text{mA}]} \text{ k}\Omega$	warming-up time	$\leq 5$ min
imprinted DC voltage	0 ... 1 to 0 ... 10 V or live-zero 0.2 ... 1 to 2 ... 10 V	<b>safety</b>	
load capacity	max. 2 mA	protection class	II, (protection isolated, DIN EN 61010)
external resistance	$R_{Bmin} = \frac{U_A[\text{V}]}{2 \text{ mA}} \text{ k}\Omega$	electrocution protection	IP 40, housing (test wire, EN 60529) IP 20, connection terminals (test digit, EN 60529)
<b>voltage limit by <math>R_{ext} = \infty</math></b>	$\leq 25$ V	contamination class	2
current limit	approx. $1.5 \cdot I_{AN}$	overvoltage category	III
under overload	by current output, approx. 10 mA, by voltage output	nominal isolation voltage	300 V, input (to earth) 230 V, auxiliary power 40 V, output
residual ripple	$\leq 0.5$ % p.p. by response time 300 ms	<b>weight</b>	250 g
of the output current	$\leq 2$ % p.p. by response time 50 ms		
response time	50 ms or 300 ms		

Order information see page 277



# EMBSIN 120 UV

Measuring transducers for AC current



- without auxiliary voltage supply
- housing for 35 mm DIN rail mounting

**Features/benefits**

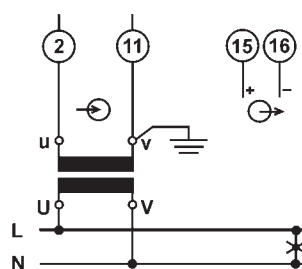
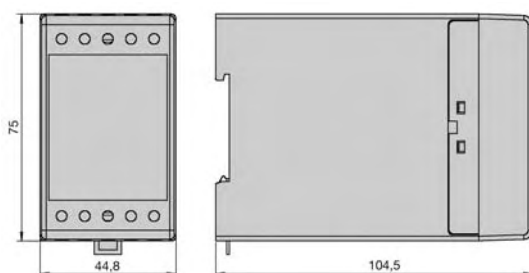
- measuring input: Sinus-shaped alternating voltage (0...20 A or 0...500 V)
- measuring output: Unipolar output signal
- measuring principle: Rectifier mean value measurement process
- without auxiliary voltage supply
- economic consumption

**Application**

Measuring transducer for the transformation of sinus-shaped alternating currents into a load-independent DC current signal, which is arranged proportionally to the input volume and is adaptable to be used for analogue and digital units.

Technical data EMBSIN 201 IE	
<b>measuring input</b>	
rated frequency $f_N$	50/60 Hz
rated input voltage $U_N$	0 ... 20 to 0 ... 500 V
	<b>linked voltage!</b>
	<b>max. input voltage to earth 250 V</b>
consumption	$\leq 2$ VA
operating temperature range	$-10$ °C $\leq \vartheta \leq +55$ °C
relative average humidity	$\leq 75$ %
overload capacity	$1.2 \cdot U_N$ , constant $2.0 \cdot U_N$ , 1 sec.
<b>measuring output</b>	
load-independent	0 ... 5, 0 ... 10 or
DC current $I_{ON}$	0 ... 20 mA
burden voltage	$\leq 15$ V
residual ripple of the output current	$\leq 1$ % p.p.
response time	$\leq 300$ ms
external resistance	$R_{Bmax} = \frac{15V}{I_{AN}[mA]}$ k $\Omega$
<b>accuracy</b>	
reference value	output end value
accuracy class	class 0.5
<b>reference conditions</b>	
ambient temperature	15 ... 30 °C
input signal	20 ... 100 % $U_N$
frequency	45 ... 65 Hz
<b>connection conditions</b>	
low voltage application	direct or via voltage transformer with a nominal performance $P \geq 5$ VA
high voltage application	via high voltage current transformer with $P \geq 5$ VA
<b>connection terminals</b>	
	$\leq 4,0$ mm <sup>2</sup> solid wire $\leq 2,5$ mm <sup>2</sup> Litze fine wire
<b>safety</b>	
protection class	II, (protection isolated, DIN EN 61010)
nominal isolation voltage	300 V, rms, connection category III 500 V, rms, connection category II
test voltage	3.7 kV, rms acc. to EN 61010-1: 1990
<b>electrocution protection</b>	
	IP 50, housing (test wire, EN 60529) IP 20, connection terminals (test digit, EN 60529)
<b>weight</b>	250 g

Order information see page 278



# EMBSIN 120 U

Measuring transducers for alternating voltage



- without auxiliary voltage supply
- housing for 35 mm DIN rail mounting

### Features/benefits

- measuring input: Sinus-shaped alternating voltage (0...20 A to 0...500 V), arithmetical mean value measurement, effective calibrated
- measuring output: Unipolar output signal
- measuring principle: Rectify process
- without auxiliary voltage supply
- minimal wiring

### Application

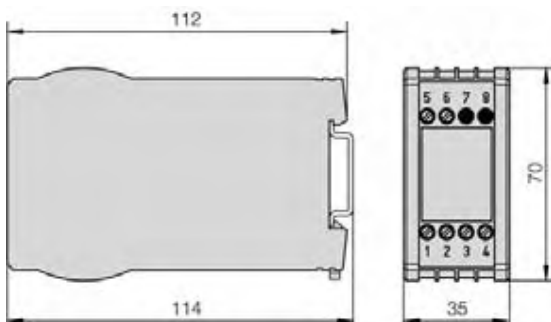
Measuring transducer for the transformation of sinus-shaped alternating voltage. A load-independent DC current signal, which is proportionally to the measurement value, serves as an output signal, and allows for the display, recording, monitoring and/or control function.

The measuring transducer fulfills the requirements and regulation with regard to the electromagnetic compatibility (EMV) and safety (IEC 1010 or EN 61010).

### Technical data EMBSIN 120 U

measuring input		accuracy	
rated frequency $f_N$	50/60 Hz	reference value	output end value
rated input voltage $U_N$	0 ... 20 to 0 ... 500 V	accuracy class	class 0.5
	<b>linked voltage!</b>	input signal	20 ... 100 %
	<b>max. input voltage to earth 250 V</b>	temperature influence (-10 ... +55 °C)	0.2 % / 10 K
consumption	≤ 2 VA	<b>safety</b>	
overload capacity	1.2 · $U_N$ , constant 2.0 · $U_N$ , 1 sec.	protection class	II, (protection isolated, DIN EN 61010)
<b>measuring output</b>		electrocution protection	IP 40, housing (test wire, EN 60529) IP 20, connection terminals (test digit, EN 60529)
load-independent DC current $I_{AN}$	0 ... 5, 0 ... 10 or 0 ... 20 mA	contamination class	2
burden voltage	≤ 15 V	nominal isolation voltage	300 V, rms, connection categorie III 500 V, rmsm connection categorie II
burden resistance	$R_{Bmax} = \frac{15V}{I_{AN}[mA]} \text{ k}\Omega$	<b>weight</b>	260 g
voltage limit			
$R_{ext} = \infty$	≤ 54 V		
current limit			
under overload	≤ 1.7 · $I_N$		
residual ripple of the output current	≤ 1 % p.p.		
response time	≤ 300 ms		

Order information see page 278



# EMBSIN 121 U

Measuring transducers for alternating voltage



- with auxiliary voltage supply  
optional measuring output 4...20 mA and/or  
2-wire technic
- housing for 35 mm DIN rail mounting

### Features/benefits

- measuring input: Sinus-shaped alternating voltage  
arithmetic mean value measurement, effective calibrated
- measuring output: Unipolar and live-zero output signal
- measuring principle: Rectifier process
- AC or DC auxiliary power

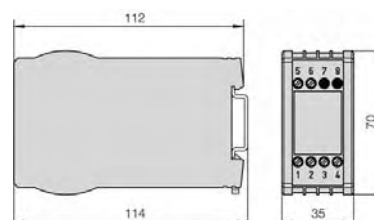
### Application

Measuring transducer for the transformation of sinus-shaped alternating voltage. A load-independent DC current signal or imprinted DC voltage signal is available which stands proportionally to the measurement value of the input volume. The measuring transducer fulfills the requirements and regulation with regard to the electromagnetic compatibility (EMV) and safety (IEC 1010 or EN 61010).

### Technical data EMBSIN 121 U

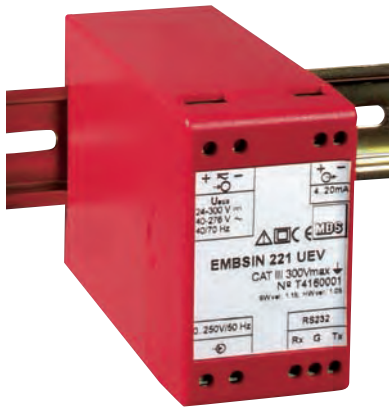
<b>measuring input</b>		<b>auxiliary power</b>	
rated frequency	50/60 Hz	AC	24, 110, 115, 120, 230 or 400 V, ± 15 %, 50/60 Hz; approx. 3 VA
rated input voltage $U_N$	0 ... 50 to 0... 600 V <b>linked voltage!</b> <b>max. 300 V nominal value of the mains to earth (operating voltage acc. to EN 61010)</b>	DC	24 V, -15/+ 33 % or 24 V, - 50/+ 33 % by 2-wire feed and output 4 ... 20 mA; approx. 1.5 W
consumption by		universal power supply ranges	DC or AC 40 ... 400 Hz 85 ... 230 V 24 ... 60 V
$U_N \leq 150$ V	< $U_N \cdot 50 \mu\text{A}$	<b>accuracy</b>	
$150 \text{ V} < U_N \leq 400$ V	< $U_N \cdot 20 \mu\text{A}$	reference value	output end value
$400 \text{ V} < U_N \leq 600$ V	< $U_N \cdot 5 \mu\text{A}$	accuracy class	class 0.5 ( $U_N \leq 500$ V) class 1 ( $U_N > 500$ V)
overload capacity	$1.2 \cdot U_N$ , constant $2.0 \cdot U_N$ , 1 sec.	<b>safety</b>	
<b>measuring output</b>		protection class	II, (protection isolated, DIN EN 61010)
load-independent DC current	0 ... 2.5 mA to 0 ... 20 mA or live-zero 1 ... 5 to 4 ... 20 mA	electrocution protection I	P 40, housing (test wire, EN 60529) IP 20, connection terminals (test digit, EN 60529)
burden voltage	$\leq 15$ V	contamination class	2
by 2-wire connection	standard range 4 ... 20 mA external resistance $R_{\text{ext}}$ , dependent of the auxiliary power H (12 ... 32 V DC) $R_{\text{ext,max.}}[\text{k}\Omega] = \frac{H[\text{V}] - 12 \text{ V}}{20 \text{ mA}}$	overvoltage category	III
imprinted DC voltage	0 ... 5 bis 0 ... 10 V or live-zero 1 ... 5 to 2 ... 10 V	nominal isolation voltage (to earth)	300 V, input 300 V, auxiliary power AC 50 V, auxiliary power 24 V DC 50 V, output
load capacity	max . 20 mA	<b>weight</b>	280 g
voltage limit			
by $R_{\text{ext}} = \infty$	$\leq 40$ V		
current limit	< 30 mA by current output		
under overload	approx. 20 mA by voltage output		
residual ripple			
of the output current	$\leq 1$ % p.p.		
response time	< 300 ms		

Order information see page 274



# EMBSIN 221 UEV

Measuring transducers for alternating voltage



- with auxiliary voltage supply
- housing for 35 mm DIN rail mounting

### Features/benefits

- measuring input: Sinus-shaped alternating voltage (0...50 to 0...500 V)
- measuring output: Unipolar and live-zero output signal
- measuring principle: Digital, true rms measuring
- with auxiliary voltage supply via AC/DC supply or AC supply
- economical consumption
- programmable measuring input and output via optional serial interface RS232 / RS485

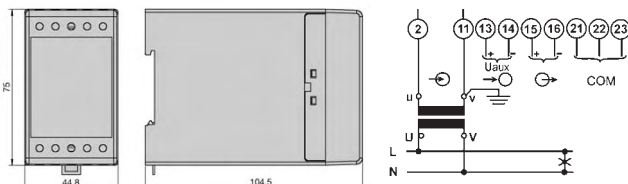
### Application

Measuring transducer for the transformation of sinus-shaped or distorted alternating voltage into a load-independent DC current- or DC voltage signal. The analogue output signal is proportionally to the true rms value of the measuring variables and can be used for regulating analogue and digital units. The input and output volumes can be configured via an interface RS232 or RS485 by means of a parametrical software „MBSset“. Before setting the parameter, the output ranges have to be tuned via jumpers. There is a choice of 3 output signals.

### Technical data EMBSIN 221 UEV

measuring input		auxiliary power	
rated frequency	50/60 Hz	universal power supply	DC or AC 40...70 Hz universal
rated input voltage $U_N$	0 ... 50 to 0 ... 500 V	voltage ranges	24 ... 300 V DC and 40 ... 276 V AC
consumption	< 0.5 VA	AC power supply	45 ... 65 Hz
overload capacity	1.2 · $U_N$ , constant 2.0 · $U_N$ , 1 sec.	rated voltages:	57,74 V, 100 V, 230 V, 400 V, 500 V
		power input	≤ 3 VA
measuring output		accuracy	
load-independent DC current $I_{ON}$	0 ... 1 to 0 ... 20 mA or live-zero 0.2 ... 15 to 4 ... 20 mA	reference value	output end value
burden resistance	$R_{b,max.} = \frac{15 \text{ V}}{I_{ON}[mA]} \text{ k}\Omega$	accuracy class	class 0.5
burden voltage	≤ 15 V	reference conditions	
imprinted DC voltage $U_{ON}$	0 ... 1 to 0 ... 10 V or live-zero 0.2 ... 1 to 2 ... 10 V	ambient temperature	15 ... 30 °C
burden resistance voltage	$R_{b,min.} = \frac{U_{ON}[V]}{20 \text{ mA}}$	input signal	0 ... 100 % $I_N$
load capacity	max. 20 mA	frequency	45...65 Hz
output signalling limit		safety	
current output	125 % $I_{AN}$	protection class	II 300 V, rms, connection category III 500 V, rms, connection category II
voltage output	125 % $U_{AN}$	contamination class	2
residual ripple		test voltage	3 kV, rms, (acc. to IEC 61010-1:1990)
of the output current	≤ 1 % p.p.	electrocution protection I	P 40, housing (test wire, EN 60529) IP 20, connection terminals (test digit, EN 60529)
response time	≤ 300 ms	interface	RS232, MODBUS RTU (optional) RS485, MODBUS RTU
		connection terminals	≤ 4.0 mm <sup>2</sup> single wire ≤ 2 x 2.5 mm <sup>2</sup> Litze
		weight	approx. 300 g

Order information see page 275



	RS232	
	9-pole plug (SUB-D)	25-pole plug
Rx (21)	Tx (3)	Tx (2)
⊥ (22)	GND (5)	GND (7)
Tx (23)	Rx (2)	Rx (3)
RS485		
A (21)	DATA +	
C (22)	NC <sup>1)</sup>	
B (23)	DATA -	

1) -NC- do not connect!

# EMBSIN 221 UE

Measuring transducers for alternating voltage



- with auxiliary voltage supply
- effective value measuring
- housing for 35 mm DIN rail mounting

**Features/benefits**

- measuring input: Alternating voltage (0...20 to 0...690 V) sinus-shaped or distorted ,effective value measuring
- measuring output: Unipolar and live-zero output signals
- measuring principle: Logarithmetical process
- AC/DC auxiliary power by means of universal power supply

**Application**

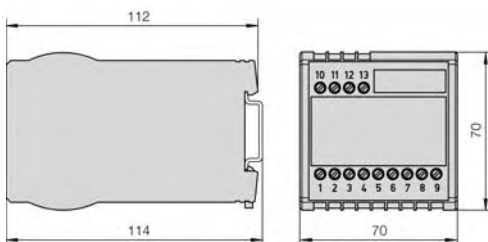
Measuring transducer for the transformation of sinus-shaped or distorted alternating voltages. A load-independent DC current signal or imprinted DC voltage signal is available, which is proportionally arranged to the rms measurement value of the input volume.

The measuring transducer fulfills the requirements and regulations with regard to the electromagnetic compatibility (EMV) and safety (IEC 1010 or EN 61010).

**Technical data EMBSIN 221 UE**

<b>measuring input</b> ⚡		<b>auxiliary power</b> ⚡	
rated frequency $f_N$	50/60 Hz or 400 Hz	universal power supply	DC or AC (40 ... 400 Hz)
rated input voltage $U_N$	0 ... 20 to 0 ... 690 V (max. 264 V by auxiliary power from voltage measuring input) max. input voltage to earth 400 V	AC/DC ranges	85 ... 230 V or 24 ... 60 V DC - 15 % / + 33 % AC ± 15 %
consumption	≤ 1 VA	power input	≤ 1.5 W (3 VA)
overload capacity	1.2 · $U_N$ , constant, 2.0 · $U_N$ , 1 sec.	accuracy	reference value output end value
<b>measuring output</b> ⚡		accuracy class	class 0.5
load-independent DC current	0 ... 1 to 0 ... 20 mA or live-zero 0.2 ... 1 to 4 ... 20 mA	peak value factor	√ 2
burden voltage	≤ 15 V	warming-up time	≤ 5 min.
imprinted DC voltage	0 ... 1 to 0 ... 10 V or live-zero 0.2 ... 1 to 2 ... 10 V	<b>safety</b>	
load capacity	max. 2 mA	protection class	II, (protection isolated, DIN EN 61010)
voltage limit bei $R_{ext} = \infty$	≤ 25 V	electrocution protection	IP 40, housing (test wire, EN 60529) IP 20, connection terminals (test digit, EN 60529)
current limit under overload	approx. 1.5 · $I_{AN}$ by current output approx. 10 mA by voltage output	contamination class	2
residual ripple of the output current	≤ 0.5 % p.p. by response time 300 ms ≤ 2 % p.p. by response time 50 ms	overvoltage category	III
response time	50 ms or 300 ms	nominal isolation voltage (to earth)	400 V, input 230 V, auxiliary power 40 V, output
		<b>weight</b>	300 g

Order information see page 277



# EMBSIN 241 FV

## Measuring transducers for frequency



- with auxiliary voltage supply
- housing for 35 mm DIN rail mounting

### Features/benefits

- Measuring transducer for measuring the frequency of sinus-shaped alternating voltages
- programmable measuring inputs and outputs by means of optional available serial interface RS232 or RS485
- low consumption
- accuracy class 0.2
- digital measuring process
- auxiliary voltage supply by means of universal AC/DC or AC supplies.

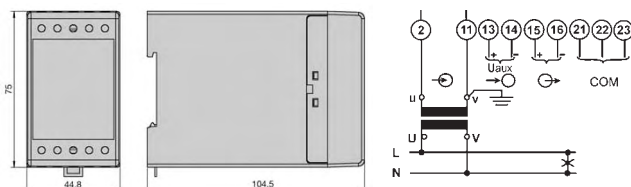
### Application

The programmable measuring transducer type EMBSIN 241 FV is being used for converting the frequency of sinus-shaped AC alternating voltage signals into a load-independent output volume. The analogue output signals (current or voltage) are arranged proportionally to the frequency of the voltage input and can be used for regulating analogue or digital units. The input volumes and output volumes can be configured via the available interface RS232 or RS484 with "MBS" parametic software.

### Technical data EMBSIN 241 FV

measuring input		auxiliary power	
measuring range	40 ... 70 Hz	universal power supply	DC or AC 40...70 Hz universal
input voltage (U <sub>i</sub> )	3 ... 500 V	voltage ranges	24 ... 300 V DC and 40 ... 276 V AC
consumption	< 0.5 VA	AC power supply	45 ... 65 Hz
overload capacity	1.2 · U <sub>N</sub> , constant	nominal voltages:	57,74 V, 100 V, 230 V, 400 V, 500 V
(acc. to IEC 60688, 1992)	2.0 · U <sub>N</sub> , 1 sec.	power input	≤ 3 VA
measuring output		accuracy	
load-independent DC current	0 ... 1 mA to 0 ... 5 mA or 0 ... 5 mA to 0 ... 20 mA	reference value	input end value
burden resistance	$R_{Bmax} = \frac{15[V]}{I_{ON} [mA]} \text{ k}\Omega$	accuracy class	class 0.2
current output		reference conditions	
burden voltage	≤ 15 V	ambient temperature	15 ... 30 °C
imprinted DC voltage	0 ... 1 V or 0 ... 10 V	input signal	0 ... 100 % I <sub>N</sub>
burden resistance	$R_{Bmin} = \frac{U_{ON} [V]}{20[mA]} \text{ k}\Omega$	frequency	45 ... 65 Hz
voltage output		safety	
output signalling limit		protection class	II 300 V, rms, connection category III 500 V, rms, connection category II
current output	125 % I <sub>AN</sub>	contamination class	2
voltage output	125 % U <sub>AN</sub>	test voltage	3 kV, rms (acc. to IEC 61010-1:1990)
residual ripple		electrocution protection	IP 40, housing (test wire, EN 60529) IP 20, connection terminals (test digit, EN 60529)
of the output current	≤ 1 % p.p.	interface	RS232, MODBUS RTU (optional) RS485, MODBUS RTU
response time	≤ 300 ms	connection terminals	≤ 4.0 mm <sup>2</sup> single wire ≤ 2 x 2.5 mm <sup>2</sup> Litze
		weight	approx. 300 g

Order information see page 279

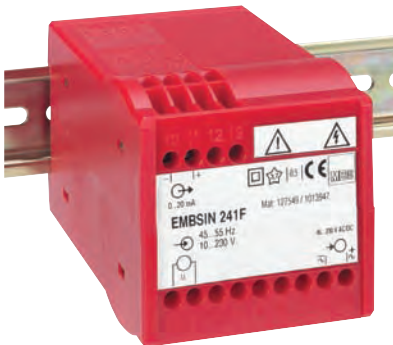


	RS232	
	9-pole plug (SUB-D)	25-pole plug
Rx (21)	Tx (3)	Tx (2)
⊥ (22)	GND (5)	GND (7)
Tx (23)	Rx (2)	Rx (3)
RS485		
A (21)	DATA +	
C (22)	NC <sup>1)</sup>	
B (23)	DATA -	

1) -NC- do not connect!

# EMBSIN 241 F

## Measuring transducers for frequency



- with auxiliary voltage supply
- housing for 35 mm DIN rail mounting

### Features/benefits

- measuring input: sinus-shaped, rectangular shaped or distorted input voltage (10 to 690 V, 10 Hz to ...1.5 kHz) with dominant basic wave
- measuring output: Unipolar, bipolar or live-zero output signal
- measuring principle: Digital constant period measuring
- AC/DC auxiliary power by means of universal power supply

### Application

Measuring transducer for frequency

A load-independent DC signal or an imprinted DC voltage signal is available which stands proportional to the frequency of the input volume. The measuring transducer fulfills the requirements and regulations with regard to the electro-magnetic compatibility of (EMV) and safety (IEC 1010 or EN 61010).

### Technical data EMBSIN 241 F

<b>measuring input</b> →		<b>auxiliary power</b> →	
rated frequency	selectable between $f_u = 10 \text{ Hz}$ and $f_o = 1500 \text{ Hz}$	universal power supply	DC or AC (40 ... 400 Hz) DC -15 % / + 33 % 1.5 W AC ±15 % 3 VA
min. range	$f_u / (f_o - f_u) < 50$	AC / DC	24 ... 60 V or 85 ... 230 V
rated input voltage $U_N$	10 ... 230 V or 230 ... 690 V	or AC-auxiliary power from	24 ... 60 V or 85 ... 230 V,
consumption	$< U_N \cdot 1.5 \text{ mA}$	voltage measuring input	(40 Hz ≤ f ≤ 400 Hz) ± 15 %
overload capacity	1.2 · $U_N$ , constant 2.0 · $U_N$ , 1 sec. (max. 264 V by auxiliary power from voltage measuring input)	<b>accuracy</b>	
wave shape	any, only basic wave will be considered	reference value	output range
<b>measuring output</b> →		accuracy class	class 0.2
load-independent DC current	0 ... 1 to 0 ... 20 mA or unipolar live-zero 1 ... 5 to 4 ... 20 mA	<b>safety</b>	
bipolar	± 1 to ± 20 mA	protection class	II, (protection isolated, DIN EN 61010)
burden voltage	≤ +15 V, resp. -12 V	electrocution protection	IP 40, housing (test wire, EN 60529) IP 20, connection terminals (test digit, EN 60529)
imprinted DC voltage	0 ... 1 to 0 ... 10 V or	contamination class	2
unipolar	live-zero 0.2 ... 1 to 2 ... 10 V	overvoltage category	III
bipolar	± 1 to ± 10 V	nominal isolation voltage	230 or 400 V, input (to earth) 230 V auxiliary power 40 V output
load capacity	max. 4 mA	<b>weight</b>	230 g
voltage limit			
by $R_{ext} = \infty$	≤ 25 V		
current limit	approx. 1.3 · $I_{AN}$ by current output		
under overload	approx. 30 mA by voltage output		
residual ripple			
of the output current	< 0.5 % p.p.		
nominal value response time	4 periods of the measuring frequency		
other ranges	2, 8 or 16 periods of the measuring frequency		

Order information see page 280

# EMBSIN 241 FD

Measuring transducers for frequency difference



- housing for 35 mm DIN rail mounting

### Features/benefits

- measuring inputs: Sinus-shaped, rectangular or distorted input voltage (10 to 690 V,  $\Delta f = \pm 1 \% f_s$  to  $\pm 80 \% f_s$ ,  $f_s$  and  $f_G \geq 10$  Hz to  $\leq 1.5$  kHz) with dominant basic wave
- measuring output: Unipolar, bipolar, or live-zero output signal
- measuring principle: Digital, constant period measuring
- AC/DC auxiliary power by means of universal power supply

### Application

Measuring transducers for monitoring the frequency difference between two synchronized supplies. A load-independent DC signal or an imprinted DC voltage signal is available as an output signal, which stands proportionally to the measuring value. The measuring transducer fulfills the requirements and regulations with regard to the electromagnetic compatibility (EMV) and safety (IEC 1010 or EN 61010).

### Technical data EMBSIN 241 FD

<b>measuring input</b>		nominal value of the response time	4 periods of the measuring frequency
measuring range	$\Delta f = \pm 1 \% f_s$ to $\pm 80 \% f_s$ ; $f_s$ and $f_G \geq 10$ Hz to $\leq 1.5$ kHz	other ranges	2, 8 or 16 periods of the measuring frequency
input voltage $U_N$	generator or bus bar 10 ... 230 V or 230 ... 690 V Three-phase system! Input voltage = linked voltage (max. 230 V by auxiliary power from voltage measuring input)	<b>auxiliary power</b>	
consumption	$< U_N \cdot 1.5$ mA per measuring input	universal power supply	DC or AC (40 ... 400 Hz)
overload capacity	$1.2 \cdot U_N$ , constant $2.0 \cdot U_N$ , 1 sec. (max. 264 V by auxiliary power from voltage measuring input)	AC/DC ranges	85 ... 230 V or 24 ... 60 V
wave shape	any, only basic wave will be considered	or auxiliary power from voltage measuring input	24 ... 60 V to 85 ... 230 V at 40 Hz $\leq f \leq$ 400 Hz
<b>Measuring output</b>		power input	approx. 2 W or 4 VA
load-independent DC current unipolar	0 ... 1 to 0 ... 20 mA or live-zero 1 ... 5 to 4 ... 20 mA	<b>accuracy</b>	
bipolar	$\pm (1 \dots 20)$ mA	reference value	nominal value output
burden voltage	$\leq 15$ V or $\geq -12$ V	accuracy class	class 0.2
imprinted DC voltage unipolar	0 ... 1 to 0 ... 10 V or live-zero 0.2 ... 1 to 2 ... 10 V	<b>safety</b>	
bipolar	$\pm (1 \dots 10)$ V	protection class	II, (protection isolated, DIN EN 61010)
load capacity	max. 4 mA	electrocution protection	IP 40, housing (test wire, EN 60529) IP 20, connection terminals (test digit, EN 60529)
voltage limit by $R_{ext} = \infty$	$\leq 25$ V	contamination class	2
current limit under overload	approx. $1.3 \cdot I_{AN}$ by current output approx. 30 mA at voltage output	overvoltage category	III
residual ripple of the output current	$< 0.5 \%$ p.p.	nominal isolation voltage (to earth)	230 V or 400 V, input 230 V, auxiliary power 40 V, output
		<b>weight</b>	270 g

Order information see page 280

# EMBSIN 271 G

## Measuring transducers for phase angle



- housing for 35 mm DIN rail mounting

### Features/benefits

- measuring input: Sinus-shaped, rectangular or distorted input volumes with dominant basic wave
- input signal: 1 A or 5 A, 10 V to 690 V
- measuring range: Phase angle  $-180^\circ \text{ el} \leq \varphi \leq +180^\circ \text{ el}$
- measuring output: Unipolar, bipolar or live-zero output signal
- measuring principle: Monitoring of the zero currents
- AC/DC auxiliary power by means of universal power supply

### Application

Measuring transducers for measuring of phase angle between current and voltage of a sinus-shaped single-phase supply or a symmetric load of a three-phase supply. A load-independent DC current signal or imprinted DC voltage signal is available, which is proportionally arranged to the phase angle between the measuring signal of current and voltage. The measuring transducer fulfills the requirements and regulations with regard to the electromagnetic compatibility (EMV) and safety (IEC 1010 or EN 61010).

### Technical data EMBSIN 271 G

<b>measuring input</b> $\oplus$		residual ripple of the output current	< 0.5 % p.p.
measuring range	- 175°el ... 0 ... + 175°el	nominal value of the response time	4 periods of the measuring frequency
phase angle	min. measuring range $\geq 20^\circ \text{el}$	other ranges	2, 8 or 16 periods of the measuring frequency
nominal frequency $f_N$	16 2/3 ... 400 Hz	<b>auxiliary power</b> $\oplus \circ$	
input voltage $U_N$	10 ... 690 V (max. 230 V by auxiliary power from voltage measuring input)	universal power supply	DC or AC (40 ... 400 Hz)
rated input current $I_N$	1 A or 5 A	AC/DC ranges	85 ... 230 V or 24 ... 60 V
consumption	< 0.1 VA current path $U_N \cdot 1.5 \text{ mA}$ voltage path	or auxiliary power from voltage measuring input	85 ... 230 V or 24 ... 60 V
overload capacity	1.2 · $I_N$ , constant 1.2 · $U_N$ , constant 20 · $I_N$ , 1 sec. 2.0 · $U_N$ , 1 sec. (max. 264 V by auxiliary power from voltage measuring input)	power input	$\leq 2 \text{ W}$ (4 VA)
<b>measuring output</b> $\oplus \rightarrow$		<b>accuracy</b>	
load-independent DC current unipolar	0 ... 1 to 0 ... 20 mA or live-zero 1 ... 5 to 4 ... 20 mA	reference value	$\emptyset_\varphi = 90^\circ$
bipolar	$\pm (1 \dots 20) \text{ mA}$	accuracy class	class 0.5
burden voltage	$\leq +15 \text{ V}$ or $\geq -12 \text{ V}$	<b>safety</b>	
imprinted DC voltage unipolar	0 ... 1 to 0 ... 10 V or live-zero 0.2 ... 1 to 2 ... 10 V	protection class	II, (protection isolated, DIN EN 61010)
bipolar	$\pm (1 \dots 10) \text{ V}$	electrocution protection	IP 40, housing (test wire, EN 60529) IP 20, connection terminals (test digit, EN 60529)
load capacity	max. 4 mA	contamination class	2
voltage limit by $R_{\text{ext}} = \infty$	$\leq 25 \text{ V}$	overvoltage category	II
current limit under overload	approx. $1.3 \cdot I_{AN}$ by current output approx. 30 mA by voltage output	nominal isolation voltage (to earth)	230 V or 400 V, input 230 V, auxiliary power 40 V, output
		<b>weight</b>	240 g

Order information see page 281



# EMBSIN 271 GD

Measuring transducers for phase angle difference

## • housing for 35 mm DIN rail mounting

### Features/benefits

- measuring input: Sinus-shaped, rectangular or distorted rated input voltages 10 to 690 V,  $\pm 10^\circ \text{ el} \leq \varphi \leq \pm 180^\circ \text{ el}$  with dominant basic wave
- measuring output: Unipolar, bipolar or live-zero output signal
- measuring principle: Monitoring of the zero currents
- AC/DC auxiliary power by means of universal power supply

### Application

Measuring transducers for monitoring of the phase angle difference between two synchronized supplies. A load-independent DC current signal or imprinted DC voltage signal is available which is proportionally arranged to the measuring value. The measuring transducer fulfills the requirements and regulations with regard to the electromagnetic compatibility (EMV) and safety (IEC 1010 or EN 61010).

### Technical data EMBSIN 271 GD

<b>measuring input</b> $\oplus$		<b>auxiliary power</b> $\leftrightarrow$	
measuring range	- 120° ... 0 ... 120° el	universal power supply	DC or AC (40 ... 400 Hz) DC (- 15 ... + 33 %) AC ( $\pm 15$ %; 40 ... 400 Hz)
rated frequency $f_N$	50 or 60 Hz	AC/DC ranges	85 ... 230 V or 24 ... 60 V
input voltages $U_N$	generator and bus bar 10 ... 230 V or 230 ... 690 V Three-phase system! $U_N$ = linked voltage (max. 230 V by auxiliary power from voltage measuring input)	power input	$\leq 2$ W (4 VA)
consumption	$< U_N \cdot 1.5$ mA per measuring input	<b>accuracy</b>	
overload capacity	1.2 · $U_N$ , constant 2.0 · $U_N$ , 1 sec. (max. 264 V by auxiliary power from voltage measuring input)	reference value	$\varnothing_\varphi = 90^\circ$
		accuracy class	class 0.5
<b>measuring output</b> $\oplus \rightarrow$		<b>safety</b>	
load-independent DC current	0 ... 1 to 0 ... 20 mA or	protection class	II, (protection isolated, DIN EN 61010)
unipolar	live-zero 1 ... 5 to 4 ... 20 mA	electrocution protection	IP 40, housing (test wire, EN 60529) IP 20, connection terminals (test digit, EN 60529)
bipolar	$\pm (1 \dots 20)$ mA	contamination class	2
burden voltage	$\leq +15$ V, resp. $\geq -12$ V	overvoltage category	III
imprinted DC voltage	0 ... 1 to 0 ... 10 V or	nominal isolation voltage	230 V or 400 V, input (to earth) 230 V, auxiliary power 40 V, output
unipolar	live-zero 0.2 ... 1 to 2 ... 10 V	<b>weight</b>	270 g
bipolar	$\pm (1 \dots 10)$ V		
load capacity	max. 4 mA		
voltage limit by $R_{\text{ext}} = \infty$	25 V		
current limit	approx. $1.3 \cdot I_{AN}$ by current output		
under overload	approx. 30 mA by voltage output		
residual ripple			
of the output current	$< 0.5$ % p.p.		
nominal value of the	4 periods of the		
response time	measuring frequency		
other ranges	2, 8 or 16 periods of the measuring frequency		

Order information see page 283

# EMBSIN 281 G

Measuring transducers for power factor



- housing for 35 mm DIN rail mounting

### Features/benefits

- measuring input: Sinus-shaped, rectangular or distorted rated input signal with dominant basic wave
- input signals: 1 A or 5 A, 10 V to 690 V
- power factor  $\cos 0.5$  cap.-1-0.5 ind.
- measuring output: Unipolar, bipolar or live-zero output signal
- measuring principle: Monitoring the distance of zero currents
- AC/DC auxiliary power by means of universal power supply

### Application

Measuring transducers for the measuring of the power factor between current and voltage of a sinus-shaped single-phase supply or a symmetric load of a three-phase supply. A load-independent DC current signal or imprinted DC voltage signal is available which is proportionally arranged to the power factor between the measuring volumes of current and volt. The measuring transducer fulfills the requirements and regulations with regard to the electromagnetic compatibility (EMV) and safety (IEC 1010 or EN 61010).

### Technical data EMBSIN 281 G

<b>measuring input</b> $\oplus$		<b>auxiliary power</b> $\rightarrow \circ$	
power factor $\cos \varphi$	0.5-cap-1-ind-0.5	universal power supply	DC or AC (40 ... 400 Hz)
rated frequency $f_N$	16 2/3 ... 400 Hz	AC/DC ranges	85 ... 230 V or 24 ... 60 V
input voltage $U_N$	10 ... 690 V (max. 230 V by auxiliary power from voltage measuring input)	or auxiliary power from voltage input	85 ... 230 V or 24 ... 60 V
rated input current $I_N$	1 A or 5 A	power input	$\leq 2$ W (4 VA)
consumption	< 0.1 VA current path $U_N \cdot 1.5$ mA voltage path	<b>accuracy</b>	
overload capacity	1.2 · $I_N$ , constant 1.2 · $U_N$ , constant 20 · $I_N$ , 1 sec. 2.0 · $U_N$ , 1 sec. (max. 264 V by auxiliary power from voltage measuring input)	reference value	$\emptyset \cos \varphi = 0.5$
<b>measuring output</b> $\oplus \rightarrow$		accuracy class	class 0.5
load-independent DC current unipolar	0 ... 1 to 0 ... 20 mA or live-zero 1 ... 5 to 4 ... 20 mA	<b>safety</b>	
bipolar	$\pm (1 \dots 20)$ mA	protection class	II, (protection isolated, DIN EN 61010)
burden voltage	$\leq +15$ V resp. $\geq -12$ V	electrocution protection	IP 40, housing (test wire, EN 60529) IP 20, connection terminals (test digit, EN 60529)
imprinted DC voltage unipolar	0 ... 1 to 0 ... 10 V or live-zero 0.2 ... 1 to 2 ... 10 V	contamination class	2
bipolar	$\pm (1 \dots 10)$ V	overvoltage category	III
load capacity	max. 4 mA	nominal isolation voltage (to earth)	230 V or 400 V, input 230 V, auxiliary power 40 V, output
voltage limit by $R_{\text{ext}} = \infty$	$\leq 25$ V	<b>weight</b>	260 g
current limit under overload	approx. 1.3 · $I_{AN}$ by current output approx. 30 mA by voltage output		
residual ripple of the output current	< 0.5 % p.p.		
nominal value of the response time	4 periods of the measuring frequency		
other ranges	2, 8 or 16 periods of the measuring frequency		

Order information see page 281

# EMBSIN 351 P

## Measuring transducers for active power



- housing for 35 mm DIN rail mounting

### Features/benefits

- measuring input: Sinus-shaped nominal input currents (1 A or 5 A) and nominal input voltages (100 V to 690 V)
- measuring output: Unipolar, bipolar or live-zero output signal
- measuring principle: Impulse width modulation (TDM-process), TDM = time division multiplication
- AC/DC auxiliary power by means of universal power supply

### Application

Measuring transducer for the transformation of the active power of a single-phase alternative AC current or three-phase current supply of equal or unequal phase load.

A load-independent DC current signal or imprinted DC voltage signal is available, which is proportionally arranged to the measuring value of the active power.

The measuring transducers fulfill the requirements and regulations, with regard to the electromagnetic compatibility (EMV) and safety (IEC 1010 or EN 61010).

### Technical data EMBSIN 351 P

<b>measuring input</b>		<b>auxiliary power</b>	
rated frequency $f_N$	50 Hz or 60 Hz	universal power supply	DC or AC (40 ... 400 Hz)
rated input voltage $U_N$	3-phase system $U_N$ = linked voltage 10 ... 690 V (max. 230 V by auxiliary power from voltage measuring input)	AC/DC	85 ... 230 V or 24 ... 60 V
rated input current $I_N$	1 A or 5 A	or auxiliary power from voltage measuring input	$\geq 85$ V to $\leq 230$ V AC
calibration factor $c$	0.75 to 1.3 by active power	power input	$\leq 2.5$ W (4.5 VA)
permissible measuring range	by active power (0.75 ... 1.3) · $\sqrt{3}$ · $U_N$ · $I_N$	<b>accuracy</b>	
consumption	< 0.1 VA per current path $U_N$ · 1 mA per voltage path	reference value	output end value
overload capacity	1.2 · $I_N$ , constant; 20 $I_N$ , 1 sec. 1.2 · $U_N$ , constant; 2.0 $U_N$ , 1 sec. (max. 264 V by auxiliary power from voltage measuring input)	accuracy class	class 0.5
<b>measuring output</b>		<b>safety</b>	
load-independent DC current unipolar	0 ... 2.5 to 0 ... 20 mA or live-zero 1 ... 5 to 4 ... 20 mA	protection class	II, (protection isolated, DIN EN 61010)
bipolar	$\pm$ (2.5 ... 20) mA	electrocution protection	IP 40, housing (test wire, EN 60529) IP 20, connection terminals (test digit, EN 60529)
burden voltage	$\pm 15$ V	contamination class	2
imprinted DC voltage unipolar	0 ... 10 V or live-zero 2 ... 10 V	overvoltage category	III
bipolar	$\pm 10$ V	nominal isolation voltage (to earth)	400 V, input 230 V, auxiliary power 40 V, output
load capacity	max. 4 mA	<b>weight</b>	700 g
voltage limit by $R_{ext} = \infty$	$\leq 40$ V		
current limit under overload	approx. 1.3 · $I_{AN}$ by current output approx. 30 mA by voltage output		
residual ripple of the output current	< 2 % p.p.		
response time	< 300 ms		

Order information see page 284

# EMBSIN 361 Q

Measuring transducers for re-active power



- housing for 35 mm DIN rail mounting

### Features/benefits

- measuring input: Sinus-shaped nominal input currents (1 A or 5 A) and nominal input voltages (100 V to 690 V)
- measuring output: Unipolar, bipolar or live-zero output signal
- measuring principle: Impulse width modulation (TDM-process), TDM = time division multiplication
- AC/DC auxiliary power by means of universal power supply

### Application

Measuring transducer for the transformation of the re-active power of a single-phase alternative AC current or three-phase current supply of equal or unequal phase load.

A load-independent DC current signal or imprinted DC voltage signal is available, which is proportionally arranged to the measuring value of the re-active power.

The measuring transducers fulfill the requirements and regulations, with regard to the electromagnetic compatibility (EMV) and safety (IEC 1010 or EN 61010).

### Technical data EMBSIN 361 Q

<b>measuring input</b>		<b>auxiliary power</b>	
rated frequency $f_N$	50 Hz	universal power supply	DC or AC (40 ... 400 Hz)
rated input voltage $U_N$	Three-phase system $U_N$ = linked voltage 10 ... 690 V (max. 230 V by auxiliary power from voltage measuring input)	AC/DC	85 ... 230 V or 24 ... 60 V
rated input current $I_N$	1 A or 5 A	or auxiliary power from voltage measuring input	$\geq 85$ V to $\leq 230$ V AC
calibration factor $c$	0.5 to 1.0 by re-active power	power input	$\leq 2.5$ W (4.5 VA)
permissible measuring range end values	by re-active power $(0.5 \dots 1.0) \cdot \sqrt{3} \cdot U_N \cdot I_N$	<b>accuracy</b>	
consumption	$< 0.1$ VA per current path $U_N \cdot 1$ mA per voltage path	reference value	output end value
overload capacity	$1.2 \cdot I_N$ , constant; $20 I_N$ , 1 sec. $1.2 \cdot U_N$ , constant; $2.0 U_N$ , 1 sec. (max. 264 V by auxiliary power from voltage measuring input)	accuracy class	class 0.5
<b>measuring output</b>		<b>safety</b>	
load-independent DC current unipolar	0 ... 2.5 to 0 ... 20 mA or live-zero 1 ... 5 to 4 ... 20 mA	protection class	II, (protection isolated, DIN EN 61010)
bipolar	$\pm (2.5 \dots 20)$ mA	electrocution protection	IP 40, housing (test wire, EN 60529) IP 20, connection terminals (test digit, EN 60529)
burden voltage	$\pm 15$ V	contamination class	2
imprinted DC voltage unipolar	0 ... 10 V bzw. live-zero 2 ... 10 V	overvoltage category	III
bipolar	$\pm 10$ V	nominal isolation voltage (to earth)	400 V, input 230 V, auxiliary power 40 V, output
load capacity	max. 4 mA	<b>weight</b>	700 g
voltage limit by $R_{ext} = \infty$	$\leq 40$ V		
current limit under overload	approx. $1.3 \cdot I_{AN}$ by current output approx. 30 mA by voltage output		
residual ripple of the output current	$< 2$ % p.p.		
response time	$< 300$ ms		

Order information see page 284

# EMBSIN 301

## Programmable measuring transducers for alternating current



### Features/benefits

- auxiliary power supply 230 V AC or 24 V DC.
- two remote controlable measuring ranges from 20...600 A AC
- two simultaneously available analogue measuring outputs
- programmable output characteristic curves
- current circuit control by means of programmable control circuits
- information of the actual operation conditions through two open collector transistors in connection with simultaneous signalling of colored light emittance diodes

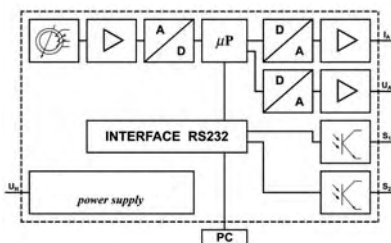
### Application

Programmable measuring transducer for monitoring sinus-shaped as well as distorted AC currents in the rated current range of 20 ... 600 A. Inductive, galvanically separated measuring value collection is secured by means of an integrated current transformer.

As an output signal, proportionally arranged to the measurement value (rms) a DC current signal and an imprinted DC voltage signal is available. By means of an integrated **interface RS232** the following additional power features can be realized:

- adjustment of the output characteristics of the analogue outputs 0(4) ...20 mA or 0(2) ...10 V
- nominal current control by means of two programmable control circuits
- optimal signalling of the actual value of the measuring volumes in realiance to the tuned control circuits by means of three-coloured light emittance diodes
- energizing of the switch operations (i.e.  $I_{min}/I_{max}$ -monitoring) by means of two open collector transistors, designated to the tuned switch circuits
- measuring value continuous monitoring of measuring values and data saving, when interacting with external computers.

Basic circuit diagram



Dimensions:

Depth x length x height:  
(87.5 x 70 x 114 mm)

### Technical data EMBSIN 301

<b>measuring input</b>		<b>accuracy</b>	
measuring variable	sinus-shaped or distorted alternating current	reference value	nominal output value
measuring range	20 ... 600 A AC	accuracy class	class 0.5 (0.5 % from output end value)
rated frequency $f_N$	50 Hz	working range	1 ... 120 % $I_N$
consumption	< 0.5 VA	warming-up time	≤ 5 min
overload capacity	1.5 · $I_N$ , constant 8.0 · $I_N$ , 40 sec.	<b>auxiliary power</b>	
<b>measuring output</b>		AC	230 V ± 10 %
<b>current output</b>		DC (optional)	24 V ± 15 %
load-independent DC current	0...20 mA or live-zero 4...20 mA, programmable by means of software	<b>operating conditions</b>	
max. burden voltage	≤ 15 V DC	field of operation	indoors without humidity
max. burden resistance	$R_B \leq 500 \Omega$	working temperature	- 5 °C ≤ $\vartheta$ + 45 °C
residual ripple of the output current	< 0.5 % p.p.	storage temperature	- 40 °C ≤ $\vartheta$ + 70 °C
current limit under overload	≤ 30 mA	<b>energizing</b>	
<b>voltage output</b>		2 open-collector transistor outputs	for load current dependent monitoring of relay controls; programmable control circuits via units software
imprinted DC voltage unipolar	0...10 V or live-zero 2...10 V, programmable by means of software	$U_{CEmax}$	50 V
min. burden resistance	≤ 10 kΩ	$I_{CEmax}$	35 mA
voltage limit by $R_{ext} = \infty$	≤ 15 V	<b>interface</b>	
response time of the output signal	50 ms	series	RS 232, connection via 9-pole SUB-D-plug
		<b>standard</b>	IEC 60688 IEC 61000

Order information see page 285

# EMBSIN 391 PV

Programmable measuring transducers  
for all electrical parameters



- with auxiliary voltage supply housing for 35 mm DIN rail mounting

### Features/benefits

- multifunctional measuring transducer for the simultaneous distribution of 3 parameters of the electrical system
- monitoring of up to 50 different parameters (V, A, kW, kVA, ...)
- programmable measuring inputs and measuring outputs
- low power consumption
- auxiliary power supply by means of universal AC/DC or AC power
- accuracy class 0.5
- serial interface, RS 232 or RS 485 (optional)
- max. 3 analogue outputs

### Application

The programmable measuring transducer EMBSIN 391 PV allows for the simultaneous distribution of 3 parameters of the electrical network. Large input ranges of the parameters allow for the monitoring of almost all standardized AC voltages and AC currents. At the measuring output of the transducer are three galvanically separated, load-independent, analogue output signals available, which are proportionally arranged to the input parameters. These output signals (DC voltage or DC current) can be used for monitoring/controlling of analogue or digital units.

### Technical data EMBSIN 391 PV

<b>measuring input</b> $\oplus$		<b>auxiliary power</b> $\rightarrow \circ$	
rated input voltage	50 V to 500 V AC (phase against neutral)	universal power supply voltage ranges	DC or AC 40...70 Hz universal 24 ... 300 V DC and 40 ... 276 V AC
rated input current	0.5 A to 5.0 A AC	AC power supply	45 ... 65 Hz
overload capacity		nominal voltages:	57.74 V, 100 V, 230 V, 400 V, 500 V
current input	$2 \cdot I_N$ , constant $20 \cdot I_N$ , 1 sec.	power input	$\leq 3$ VA
voltage input	$1.5 \cdot U_N$ , constant $2.0 \cdot U_N$ , 1 sec.	<b>accuracy</b>	
<b>measuring output (analogue)</b> $\rightarrow \oplus$		reference value	end value of the input volume
nominal current output range ( $I_{AN}$ ), parametrical	0 ... 1 mA to 0 ... 20 mA	accuracy class	class 0.5
max. burden voltage	$U_B \leq 15$ V	<b>reference conditions</b>	
burden resistance current	$R_{MAX} [k\Omega] = 15V / I_{AN} [mA]$	ambient temperature	15 ... 30 °C
nominal voltage output ranges ( $U_{AN}$ ), parametrical	0 ... 1 V to 0 ... 10 V	input signal	0 ... 100 % $I_N$
max. burden current	20 mA	frequency	45 ... 65 Hz
burden resistance voltage	$R_{MIN} [k\Omega] = U_{AN} / 20$ mA	<b>safety</b>	
residual ripple of the output current	$\leq 1$ % p.p.	protection class	IP50 300 V, rms, connection category III 500 V, rms, connection category II
response time	$\leq 300$ ms	contamination class	2
		test voltage	3 kV, rms (acc. to IEC 61010-1: 1990)
		electrocution protection	IP 40, housing (test wire, EN 60529) IP 20, connection terminals (test digit, EN 60529)
		working temperature	-10 °C $\leq \vartheta \leq$ + 55 °C
		<b>interface</b> (optional)	RS232, MODBUS RTU RS485, MODBUS RTU
		<b>connection terminals</b>	$\leq 4.0$ mm <sup>2</sup> solid wire $\leq 2.5$ mm <sup>2</sup> Litze fine wire
		<b>weight</b>	
		with AC power supply	approx. 600 g
		with universal power supply	approx. 500 g

Order information see page 285

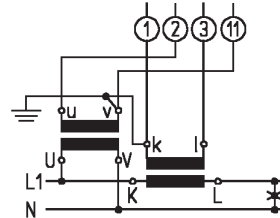
Connection diagram see page 268  
Specification see page 269

# EMBSIN 391 PV

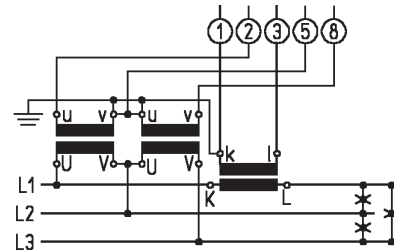
Programmable measuring transducers for all electrical parameters

### Connection diagram

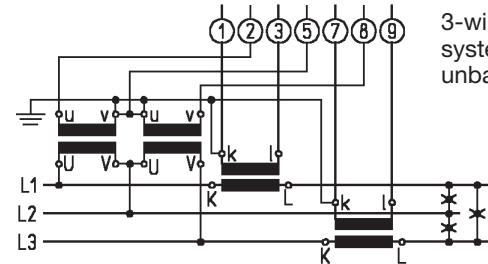
The voltage inputs of the measuring transducer can be connected directly to a low voltage network or to a high voltage network via a high voltage transformer. The current inputs of the measuring transducer can be directly connected to a low voltage network via a low voltage current transformer or to a high voltage network via a high voltage current transformer.



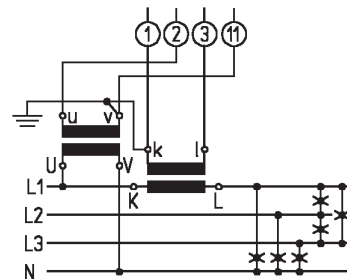
single-phase system - 1b



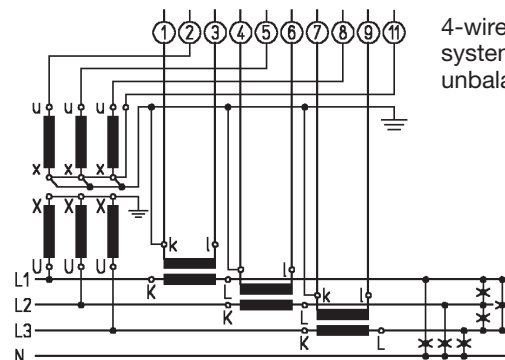
3-wire three-phase system - 3b, balanced load



3-wire three-phase system - 3u, unbalanced load



4-wire three-phase system - 4b, balanced load



4-wire three-phase system - 4u, unbalanced load

Function		Connection	
measuring input	AC current	I <sub>L1</sub>	1/3
		I <sub>L2</sub>	4/6
		I <sub>L3</sub>	7/9
	AC voltage	U <sub>L1</sub>	2
		U <sub>L2</sub>	5
		U <sub>L3</sub>	8
measuring outputs	output 1	+	15
		-	16
	output 2	+	17
		-	18
	output 3	+	19
		-	20
auxiliary voltage supply	DC +/- AC	13	
	- / AC	14	
interface (optional)	RS232/RS485	R <sub>x</sub> / A	21
		≠ / NC <sup>1)</sup>	22
		T <sub>x</sub> / B	23

1) -NC- do not connect!

continuation see page 269

# EMBSIN 391 PV

Programmable measuring transducers  
for all electrical parameters

Specifications		
Description		EMBSIN 391 PV
auxiliary voltage		with auxiliary voltage supply
measuring principle		microprocessor sampling
<b>inputs</b>		
rated input voltage		programmable, 0...50 V to 0...500 V
rated input current		programmable, 0...0.5 to 0...5 A
rated frequency		45...65 Hz
<b>outputs</b>		
number of available analogue outputs		3 with AC/DC power supply 1 with AC power supply
output voltage ranges		programmable, -10...+10 V to -1...+1 V
output current ranges		programmable, -20...+20 mA to -1...+1 mA
interface		RS232 or RS485
<b>measuring variables</b>		
current	phase current I <sub>1</sub> , I <sub>2</sub> , I <sub>3</sub> and mean value current I <sub>avg</sub>	
	voltage	phase to neutral voltage U <sub>1</sub> , U <sub>2</sub> , U <sub>3</sub> and mean value to neutral value voltage
voltage		linked voltages U <sub>1</sub> -U <sub>2</sub> , U <sub>2</sub> -U <sub>3</sub> , U <sub>3</sub> -U <sub>1</sub> and mean value of the linked voltages U <sub>avg</sub> (pp)
	frequency	
active power		a, b
re-active power		a, b
apparent power		a, b
power factor		a, b
phase angle		a, b
% THD distortion factor		a, b
instantaneous value monitoring	phase current	a, b
	total apparent power	a, b
	total active power	a, b
	total re-active power	a, b
maximal value monitoring	phase current	a, b
	total apparent power	a, b
	total active power	a, b
	total re-active power	a, b

a - measuring value is available via analogue output

b - measuring value is visual via interface

**Order information see page 285**



# EMBSIN 391

Programmable measuring transducers for all electrical parameters

- housing for 35 mm DIN rail

### Features/benefits

- measuring inputs: Sinus-shaped input currents 0...7.5 A, sinus-shaped input voltages 0...690 V
- measuring outputs: 3 simultaneously available unipolar, bipolar or live-zero measuring outputs (current or voltage). The outputs can be assigned to several measuring parameters
- AC/DC auxiliary power supply, universal power supply
- programmable interface: Serial RS232 C

### Application

The EMBSIN 391 is a programmable, multi measuring transducer for electrical power current variables. It monitors simultaneously 3 measuring variables of a single-phase AC current or three-phase AC current network of equal or unequal load. As an output signal 3 galvanically separated load independent DC current signals or imprinted DC voltage signals are available, which are proportionally arranged to the chosen measuring values of the input parameters. The measuring transducer fulfills all requirements and regulations with regard to the electro-magnetic compatibility (EMV) and safety (IEC 1010 and EN 61010).

### Technical data EMBSIN 391

<b>measuring input</b> $\rightarrow$		<b>auxiliary voltage supply, alternatively</b> $\rightarrow$	
rated frequency $f_N$	50/60 Hz	AC / DC power supply	24 ... 60 V AC / DC 85 ... 230 V AC / DC (DC ... 50/60 Hz) (DC -15 % ... +33 %) (AC -15 % ... +15 %)
sinus-shaped input current $I_N$	0 ... 7.5 A	power input	$\leq 5$ W (7 VA)
sinus-shaped input voltage $U_N$	$U_N =$ linked voltage 0 ... 690V max. 400 V to earth !	<b>accuracy</b>	reference value      measuring range end value accuracy class      class 0.5
power input from measuring circuit		<b>safety</b>	protection class      II, (protection isolated, EN 61010-1)
- current path	$\leq I_E^2 \cdot 0.01$ W	electrocution protection	IP 40, housing (test wire, EN 60529) IP 20, connection terminals (test digit, EN 60529)
- voltage path	$\leq U_E^2 / 400$ kW	contamination class	2
interface	serial, RS232 C	nominal isolation voltage	inputs:      300 V(2) 600 V(3) auxiliary power: 230 V outputs:      40 V
<b>measuring output, user defined</b> $\rightarrow$		<b>weight</b>	370 g
3 x load independent DC current	-20 ... +20 mA	(2) overvoltage category III	
or		(3) overvoltage category II	
3 x imprinted DC current	-10 ... +10 V		
max. burden at current output	$R_B \leq \frac{15}{I_{AN}}$ [k $\Omega$ ]		
min. burden by voltage output	$R_B \leq \frac{U_{AN}}{1 \text{ mA}}$ [k $\Omega$ ]		
output signalling limit under overload :			
- current output	$1.2 \times I_{AN}$ ( $R_A = 0$ ) $\leq 30$ V (by $R_A = \infty$ )		
- voltage output	40 mA ( $R_A = 0$ ) $1.2 \times U_{AN}$ ( $R_A = \infty$ )		
residual ripple of the output current	$\leq 1$ % p.p		
response time of the output signal	1...2 x measuring cyclus time		

## Order Lists

	page
FASK	Flexible clip-on current transformer (Rogowski coil) .....272
EMBSIN 100 IV	Measuring transducer for AC current, without auxiliary voltage supply .....273
EMBSIN 100 I	Measuring transducer for AC current, without auxiliary voltage supply .....273
EMBSIN 101 I	Measuring transducer for AC current, with auxiliary voltage supply .....274
EMBSIN 201 IEV	Measuring transducer for AC current, rms measurement .....275
EMBSIN 201 IE	Measuring transducer for AC current, rms measurement .....277
EMBSIN 120 UV	Measuring transducer for AC voltage, without auxiliary voltage supply .....278
EMBSIN 120 U	Measuring transducer for AC voltage, without auxiliary voltage supply .....278
EMBSIN 121 U	Measuring transducer for AC voltage, with auxiliary voltage supply .....274
EMBSIN 221 UEV	Measuring transducer for AC voltage, with auxiliary voltage supply .....275
EMBSIN 221 UE	Measuring transducer for AC voltage, rms measurement .....277
EMBSIN 241 FV	Measuring transducer for frequency, with auxiliary voltage supply .....279
EMBSIN 241 F	Measuring transducer for frequency, with universal AC/DC power supply .....280
EMBSIN 241 FD	Measuring transducer for frequency difference with universal AC/DC power supply .....280
EMBSIN 271 G	Measuring transducer for phase angle, with universal AC/DC power supply .....281
EMBSIN 271 GD	Measuring transducer for phase angle difference, with universal AC/DC power supply ....283
EMBSIN 281 G	Measuring transducer for power factor, with universal AC/DC power supply .....281
EMBSIN 351 P	Measuring transducer for active power, with universal AC/DC power supply .....284
EMBSIN 361 Q	Measuring transducer for re-active power, with universal AC/DC power supply .....284
EMBSIN 301	Programmable measuring transducer for AC current .....285
EMBSIN 391 PV	Programmable measuring transducer for all electrical variables .....285

## Order Lists

### FASK – Current transformers with separable, flexible measuring system (Rogowski coils)

Features		Order no.										
		X	X	X	X	X	X	X	X	X	X	X
<b>1.) Type / length l</b>	<b>Type</b>	<b>coil length</b>										
	F30	30 cm										
	F40	40 cm										
	F60	60 cm										
	F75	75 cm										
	F100	100 cm										
	<b>special types on request</b>		F	9	0	0						
<b>2.) Measuring current</b>	<b>measuring range</b>	<b>coil length</b>										
	200 A AC	l = 30 cm										
	500 A AC	l = 30 cm										
	1000 A AC	l = 40 cm										
	2000 A AC	l = 60 cm										
	3000 A AC	l = 75 cm										
	3000 A AC	l = 100 cm										
<b>special value on request 100...3000 A</b>		X	X	X	X							
<b>3.) Output signal <math>U_A</math> / auxiliary voltage supply <math>U_H</math></b>	<b><math>U_A</math> [V AC]</b>	<b><math>U_H</math> [V DC]</b>										
	0.500 V AC	5 V DC										
	1.000 V AC	5 V DC										
	2.000 V AC	9 V DC										
	3.000 V AC	12 V DC										
	4...20 mA DC											
	0...1 V DC											
	0...5 V DC											
	0.21 mV/A	without power supply										
<b>4.) Lead / cord length</b>	standard l		3 x 2.0 m								1	
	special length l		max. 3 x 15.0 m								9	

## Order Lists

### EMBSIN 100 IV – Measuring transducer for AC current, without auxiliary voltage supply

Features	Order no.				
<b>EMBSIN 100 IV, measuring transducer for AC current</b> order no.: 100 I - Vxxx	100 I -	V	X	X	X
<b>1. construction</b> housing MBS, for 35 mm DIN rail		V			
<b>2. measuring range</b> 0 ... 1 A			1		
0 ... 5 A			2		
nonstandard [A], 0 ... 1 A to 0 ... 7.5 A _____ A			9		
<b>3. output signal</b> 0 ... 5 mA				1	
0 ... 10 mA				2	
0 ... 20 mA				3	
<b>4. additional text on the label</b> without additional text					0
with additional text					1

rated frequency of the measuring signal: 50/60 Hz

### EMBSIN 100 I – Measuring transducer for AC current, without auxiliary voltage supply

Features	Order no.					
<b>EMBSIN 100 I, measuring transducer for AC current</b> order no.: 100 I - Mxxxx	100 I -	M	X	X	X	X
<b>1. construction</b> housing MBS, for 35 mm DIN rail		M				
<b>2. measuring range</b> 0 ... 1 / 5 A			1			
0 ... 1.2 / 6 A			2			
9) nonstandard [A] 0 ... 0.5 A to 0 ... 7.5 A (only one measuring range!) _____ A			9			
<b>3. output signal</b> 0 ... 5 mA, Ra <= 3 kOhm				1		
0 ... 10 mA, Ra <= 1.5 kOhm				2		
0 ... 20 mA, Ra <= 750 Ohm				3		
<b>4. measuring range adjustable</b> measuring range fixed					0	
measuring end value adjustable approx. ± 10 %					1	
<b>5. test certificates</b> without test certificate						0
with test certificate in German						D
with test certificate in English						E

rated frequency of the measuring signal: 50 / 60 Hz

## Order Lists

### EMBSIN 101 I – Measuring transducer for alternating current EMBSIN 121 U – Measuring transducer for alternating voltage

Features	Order no.							
<b>EMBSIN 101 I , measuring transducer for AC current</b> order no.: 101 I - Mxx xxx	101 I -	M	X	X		X	X	X
<b>EMBSIN 121 U, measuring transducer for AC voltage</b> order no.: 121 U - Mx xxxx	121 U-	M	X			X	X	X
<b>1. construction</b> housing MBS / SP1, for 35 mm DIN rail		M						
<b>2. frequency of the input voltage / input current</b> rated frequency 50 / 60 Hz			1					
<b>3. measuring range</b>								
0 ... 1 A					A			
0 ... 5 A					B			
Z: _____ A					Z			
! Z: Nonstandard [ A ] : 0 ... 0.8 to 0 ... 1.2 or 0 ... 4 to 0 ... 6								
0 ... 100 V					A			
0 ... 250 V					B			
Z: _____ V					Z			
! Z: Nonstandard [ V ] : 0 ... 50 to 0 ... 500								
<b>max. 300 V rated voltage to earth</b> (rated voltages acc. to EN 61010)								
<b>4. output signal</b>								
0 ... 20 mA						1		
4 ... 20 mA						2		
4 ... 20 mA , 2-wire connection / feed						3		
9: _____ mA						9		
! 9: Nonstandard [ mA ] : 0 ... 2.5 to 0 ... < 20								
0 ... 10 V						A		
Z: _____ V						Z		
1 ... 5 to < ( 4... 20 )								
! Z: Nonstandard [ V ] : 0 ... 5.0 to 0 ... < 10								
1 ... 5 to 2 ... 10								
<b>5. auxiliary power</b>								
auxiliary voltage Uh : 24 V AC							1	
auxiliary voltage Uh : 110 V AC							2	
auxiliary voltage Uh : 115 V AC							3	
auxiliary voltage Uh : 120 V AC							4	
auxiliary voltage Uh : 230 V AC							5	
auxiliary voltage Uh : 400 V AC, ! max. 300 V to earth!							6	
auxiliary voltage Uh : 24 V DC							A	
auxiliary voltage Uh : 24 V DC via output circuit							B	
universal power supply 85 ... 230 V AC/DC							C	
universal power supply 24 ... 60 V AC/DC							D	
Uh ... rated voltage, permissible tolerances								
AC : - 15 % ... + 15 %								
DC : - 15 % ... + 33 %								
for DC via output circuit: - 50 % ... + 33 %								
! 1 to A not to be combined with output signal, order-no.: 3								
! B not to be combined with output signal, order no.: 1, 2, 9, A, Z								
<b>6. test certificates</b>								
without test certificate								0
with test certificate in German								D
with test certificate in English								E

## Order Lists

**EMBSIN 201 IEV – Measuring transducer for alternating current, true rms measuring**  
**EMBSIN 221 UEV – Measuring transducer for alternating voltage, true rms measuring**

Features	Order no.										
<b>EMBSIN 201 IEV, measuring transducer for AC current</b> effective value, order no.: 201 IE - Vxxxxxxx	201 IE -	V	X		X	X	X	X	X	X	X
<b>EMBSIN 221 UEV, measuring transducer for alternating voltage</b> effective value, order no.: 221 UE - Vxxxxxxx	221 UE -	V		X	X	X	X	X	X	X	X
<b>1. construction</b> housing MBS, for 35 mm DIN rail		V									
<b>2. measuring range</b>											
0 ... 1 A			1								
0 ... 5 A			2								
<b>9) _____ A</b>											
<b>! 9) 0 ... 0.2 A to 0 ... 6 A</b>			9								
0 ... 50 V				A							
0 ... 500 V				B							
<b>Z) _____ V</b>											
<b>! Z) 0 ... 50 V to 0 ... 500 V</b>				Z							
<b>3. output signal</b>											
mA				1							
V				2							
<b>4. output signal, start value</b>											
output unipolar, start value 0				1							
output live-zero, start value 20 %				2							
<b>5. output signal, end value</b>											
output signal end value: 20 mA				1							
output signal end value: 1 ... 20 mA, _____ mA				9							
output signal end value: 10 V				A							
output signal end value: 1 ... 10 V, _____ V				Z							
<b>6. auxiliary voltage</b>											
universal power supply 24 ... 300 V DC/ 40 ... 276 V AC					1	0					
AC power supply					2						
57 V						1					
100 V						3					
110 V						4					
230 V						5					
400 V						7					
500 V						8					
<b>7. type of serial interface</b>											
without interface										0	
RS 232										1	
RS 485										2	
<b>8. type of output characteristics</b>											
linear											L
curved (1)											B

(1) Please take notice of the additional information in table 2, page 276, when ordering curved output characteristics.

## Order Lists

Fortsetzung von Seite 275

### EMBSIN 201 IEV – Measuring transducer for alternating current, true rms measuring EMBSIN 221 UEV – Measuring transducer for alternating voltage, true rms measuring

Table 2

**Additional information when ordering measuring transducers with curved output characteristics**

When ordering measuring transducers with curved output characteristics the start and end points as well as the position of the required curved break of the to be adjusted transmission ratio have to be defined.

Measuring transducers of the type **EMBSIN 201 IEV / EMBSIN 221 UEV** allow the presentation of transmission characteristics of up to 5 curved breaks.

Description		Code
start value of the measuring value(s)	dependent on the measuring range	s
	0 ... +20 mA / 0 V ... +10 V	
start value of the output value	dependent on the output range	p
	0 ≤ p ≤ +20 mA / 0 ≤ p ≤ +10 V	
end value of the measuring value (s)	dependent on the measuring range	e
end value of the output value (rt) if measuring value (e)	1 mA ... +20 mA / 1 V ... +10 V	
	dependent on the output range	rt
		n1_____
		n2_____
value of the measuring value (n <sub>x</sub> )	dependent on the measuring range	n3_____
		n4_____
		n5_____
		o1_____
	0 mA ... +20 mA/ 0 V ... +10 V	o2_____
value of the output value (o <sub>x</sub> ) if measuring value (n <sub>x</sub> )	dependent on the output range	o3_____
	0 ≤ p ≤ +20/ 0 ≤ p ≤ +10	o4_____
		o5_____

## Order Lists

### EMBSIN 201 IE – Measuring transducer for alternating current EMBSIN 221 UE – Measuring transducer for alternating voltage

Features	Order no.									
<b>EMBSIN 201 IE, measuring transducer for alternating current</b> effective value, order no.: 201 IE - Mxx xx x	201 IE -	M	X	X		X	X		X	X
<b>EMBSIN 221 UE, measuring transducer for alternating voltage</b> effective value, order no.: 221 UE - Mx xx xx	221 UE-	M	X			X	X		X	X
<b>1. construction</b> housing MBS, for 35 mm DIN rail		M								
<b>2. frequency of the input current/ input voltage</b>										
rated frequency 50/60 Hz				1						
rated frequency 400 Hz				2						
<b>3. measuring range</b>										
0 ... 1.0 / 5.0 A					1					
0 ... 1.2 / 6.0 A					2					
9: _____ / _____ A					9					
Lower/higher measuring range dependent on connection availability ! 9: Nonstandard [A]: 0 ... 0.1 / 0.5 to 0 ... < 1.2 / 6 measuring range end value ratio 1 : 5										
0 ... 100 / $\sqrt{3}$ V						A				
0 ... 110 / $\sqrt{3}$ V						B				
0 ... 100 V						C				
0 ... 110 V						D				
0 ... 116.66 V						E				
0 ... 120 V						F				
0 ... 125 V						G				
0 ... 133.33 V						H				
0 ... 150 V						J				
0 ... 250 V						K				
0 ... 500 V !						L				
Z) _____ V						Z				
! Z: Nonstandard [V]: 0 ... 20 to 0 ... 690 * with auxiliary voltage from measuring input min. 24V/ max. 230V see selection criteria 5 digit 3+4 ! * > 400 V only linked voltage!										
<b>4. output signal</b>										
0 ... 20 mA						1				
4 ... 20 mA						2				
9: _____ mA						9				
0 ... 10 V						A				
Z: _____ V						Z				
! 9) Nonstandard [mA]: 0 ... 1.00 to 0 ... < 20 0.2 ... 1 to < (4 ... 20) ! Z) Nonstandard [V]: 0 ... 1.00 to 0 ... < 10 0.2 ... 1 to 2 ... 10										
<b>5. auxiliary voltage</b>										
U <sub>h</sub> : 85 ... 230 V AC/DC							1	1		
U <sub>h</sub> : 24 ... 60 V AC/DC							2	2		
from measuring input (>= 24 ... 60 V AC )								3		
from measuring input (>= 85...230 V AC )								4		
U <sub>h</sub> : 24 V AC/ 24 ... 60 V DC							5	5		
from low voltage area U <sub>h</sub> = rated voltage tolerances: DC -15 ... +33 %, AC -15 ... +15 % ! 3 not to be combined with measuring range order no.: C ... L ! 4 not to be combined with measuring range order no.: A , B, L										
<b>6. response time</b>										
300 ms, standard									1	
50 ms									2	
<b>7. test certificates</b>										
without test certificate										0
with test certificate in German										D
with test certificate in English										E

## Order Lists

### EMBSIN 120 UV - Measuring transducer for alternating voltage, without auxiliary voltage supply

Features	Order no.				
<b>EMBSIN 120 UV, measuring transducer for alternating voltage</b> order no.: 120 U - Vxxx	120 U -	V	X	X	X
<b>1. construction</b> housing MBS, for 35 mm DIN rail		V			
<b>2. measuring range</b>					
0 ... 100 / $\sqrt{3}$ V			1		
0 ... 110 / $\sqrt{3}$ V			2		
0 ... 100 V			3		
0 ... 110 V			4		
0 ... 250 V			6		
0 ... 500 V !			8		
9: _____ V					
! 9: Nonstandard [V] 0 ... 20 to 0 ... 500 V			9		
! max. 250 V rated voltage to earth, working voltage acc. to EN 61010!					
<b>3. output signal</b>					
0 ... 5 mA				1	
0 ... 10 mA				2	
0 ... 20 mA				3	
<b>4. additional text on the label</b>					
without additional text					0
with additional text					1

rated frequency of the measuring signal: 50 / 60 Hz

### EMBSIN 120 U - Measuring transducer for alternating voltage, without auxiliary voltage supply

Features	Order no.					
<b>EMBSIN 120 U, measuring transducer for alternating voltage</b> order no.: 120 U - Mxxxx	120 U -	M	X	X	X	X
<b>1. construction</b> housing MBS, for 35 mm DIN rail		M				
<b>2. measuring range</b>						
0 ... 100 / $\sqrt{3}$ V			A			
0 ... 110 / $\sqrt{3}$ V			B			
0 ... 120 / $\sqrt{3}$ V			C			
0 ... 100 V			D			
0 ... 110 V			E			
0 ... 116.66 V			F			
0 ... 120 V			G			
0 ... 125 V			H			
0 ... 133.33 V			J			
0 ... 150 V			K			
0 ... 250 V			L			
0 ... 400 V			M			
0 ... 500 V			N			
Z: _____ V			Z			
! Z: Nonstandard [V] 0...20 to 0...500 V						
! max. 250 V rated voltage to earth, working voltage acc. to EN 61010!						
<b>3. output signal</b>						
0 ... 5 mA, Ra ≤ 3 kOhm				1		
0 ... 10 mA, Ra ≤ 1.5 kOhm				2		
0 ... 20 mA, Ra ≤ 750 Ohm				3		
<b>4. measuring range adjustable</b>						
measuring range fixed					0	
measuring end value adjustable approx. ± 10 %					1	
<b>5. test certificates</b>						
without test certificate						0
with test certificate in German						D
with test certificate in English						E

## Order Lists

### EMBSIN 241 FV - Measuring transducer for frequency

Features	Order no.									
<b>EMBSIN 241 FV, measuring transducer for frequency</b> order no.: 241 F - Vxxxxxxx	241 F-	V	X	X	X	X	X	X	X	X
<b>1. construction</b> housing MBS, for 35 mm DIN rail		V								
<b>2. measuring range</b>										
40 ... 70 Hz			1							
45 ... 55 Hz			2							
48 ... 52 Hz			3							
45 ... 65 Hz			4							
55 ... 65 Hz			5							
9: (40 Hz ≤ 70 Hz) fa ≤ fe ≤ 70 Hz fa _____ Hz fe _____ Hz			9							
<b>3. output signal</b>										
mA			1							
V			2							
<b>4. output signal, start value</b>										
output signal unipolar, start value				1						
output signal live-zero, start value 20 %				2						
<b>5. output signal, end value</b>										
output signal, end value: 5 mA					1					
output signal, end value: 10 mA					2					
output signal, end value: 20 mA					3					
output signal, end value: 1 ... 20 mA, _____ mA					9					
output signal, end value: 10 V					A					
output signal, end value: 1 ... 10 V, _____ V					Z					
<b>6. auxiliary voltage</b>										
universal power supply						1	0			
AC power supply						2				
57 V							1			
100 V							3			
110 V							4			
230 V							5			
400 V							7			
500 V							8			
<b>7. type of serial interface</b>										
without interface								1		
RS232								2		
RS485								3		
<b>8. type of output characteristics</b>										
linear										L
curved (1)										B

(1) Please take notice of the additional information in table 2 mentioned below when ordering curved output characteristics.

**Table 2**

**Additional information when ordering measuring transducers with curved output characteristics**

When ordering measuring transducers with curved output characteristics the start and end points as well as the position of the required curved break of the to be adjusted transmission ratio have to be defined. Measuring transducers of the type **EMBSIN 241 FV** allow the presentation of transmission characteristics of up to 5 curved breaks.

Description		Code
start value of the measuring value (s)	dependent on the measuring range	s
start value of the output value (p)	0 mA ... +20 mA / 0 V ... +10 V	
	dependent on the output range	p
	0 mA ≤ p ≤ +20 mA / 0 ≤ p ≤ +10 V	
end value of the measuring value (e)	dependent on the measuring range	e
end value of the output value (rt) if measuring value (e)	1 mA ... +20 mA / 1 V ... +10 V	
	dependent on the output range	rt
value of the measuring value (nx)	dependent on the measuring range	n1 ... n5
	0 mA ... +20 mA / 0 V ... +10 V	
value of the output value (ox) if measuring value (nx)	dependent on the output range	o1 ... o5
	0 ≤ p ≤ +20 / 0 ≤ p ≤ +10	

## Order Lists

### EMBSIN 241 F – Measuring transducer for frequency

### EMBSIN 241 FD – Measuring transducer for frequency difference

Features	Order no.								
<b>EMBSIN 241 F, measuring transducer for frequency</b> order no.: 241 F - Mxxxxxx	241 F -	M	X	X		X	X	X	X
<b>EMBSIN 241 FD, measuring transducer for frequency difference</b> order no.: 241 FD - Mxxxxxx	241 FD-	M	X			X	X	X	X
<b>1. construction</b> housing MBS, for 35 mm DIN rail		M							
<b>2. rated nominal voltage</b> 241 FD -> generator and bus bar									
input voltage									
10 ... 230 V			1						
> 230 ... 690 V			2						
<b>! Three-phase system:</b> input voltage = linked voltage ! 2 not permissible by auxiliary voltage starting from measuring input									
<b>3. measuring range</b> 45 ... 50 ... 55 Hz					1				
47 ... 49 ... 51 Hz					2				
47.5 ... 50 ... 52.5 Hz					3				
48 ... 50 ... 52 Hz					4				
58 ... 60 ... 62 Hz					5				
9: _____ Hz					9				
! 9: Nonstandard [ Hz ]; limit values: start value $f_a > = 10$ Hz, end value $f_e < = 1500$ Hz $f_a / ( f_e - f_a ) < 50$									
$f_s = 50$ Hz / $f_g = 49.5 ... 50 ... 50.5$ Hz					1				
$f_s = 50$ Hz / $f_g = 47.5 ... 50 ... 52.5$ Hz					2				
$f_s = 50$ Hz / $f_g = 45 ... 50 ... 55$ Hz					3				
$f_s = 50$ Hz / $f_g = 40 ... 50 ... 60$ Hz					4				
$f_s = 60$ Hz / $f_g = 57.5 ... 60 ... 62.5$ Hz					5				
9: _____ Hz					9				
! 9: Nonstandard [Hz]: upon request									
<b>4. output signal</b> 0 ... 20 mA							1		
4 ... 20 mA							2		
9: _____ mA							9		
0 ... 10 V							A		
Z: _____ V							Z		
! 9: Nonstandard [mA]: 0 ... 1.0 to 0 ... < 20 mA 1.0 ... 0 ... 1.0 to -20 ... 0 ... 20 mA 1 ... 5 to < ( 4 ... 20 )									
! Z: Nonstandard [V] : 0 ... 1.0 to 0 ... < 10 V 0.2 ... 1 to 2 ... 10 V -1.0 ... 0 ... 1.0 to -10 ... 0 ... 10 V									
<b>5. auxiliary voltage</b> $U_h$ : 85 ... 230 V AC/DC							1		
$U_h$ : 24 ... 60 V AC/DC							2		
from measuring input ( $\geq 24 ... 60$ V AC )							3		
from measuring input ( $\geq 85...230$ V AC )							4		
auxiliary voltage $U_h$ : 24 V AC / 24 ... 60 V DC from low voltage side $U_h$ = rated voltage tolerances: DC -15 ... +33 %, AC -15 ... +15 % ! 3 + 4 not to be combined with input rated voltage, order no. 2							5		
<b>6. response time</b> 4 periods of input frequency								1	
2 periods of input frequency								2	
8 periods of input frequency								3	
16 periods of input frequency								4	
! 1: 4 periods = standard									
<b>7. test certificates</b> without test certificate									0
with test certificate in German									D
with test certificate in English									E

## Order Lists

### EMBSIN 271 G – Measuring transducer for phase angle EMBSIN 281 G – Measuring transducer for power factor

Features	Order no.												
<b>EMBSIN 271 G, measuring transducer for phase angle</b> order no.: 271 G - Mxxxxxxx	271 G-	M	X	X	X	X	X	X	X	X	X	X	X
<b>EMBSIN 281 G, measuring transducer for power factor</b> order no.: 281 G - Mxxxxxxx	281 G-	M	X	X	X	X	X	X	X	X	X	X	X
<b>1. construction</b> housing MBS, for 35 mm DIN rail		M											
<b>2. type of measuring</b> for phase angle (proportional phi)													
for power factor (proportional cos phi)													
<b>3. application</b> single-phase AC current													
3- or 4-phase DC current, balanced U:													
L1-L2; I : L1													
L2-L3; I : L2													
L3-L1; I : L3													
L1-L3; I : L1													
L2-L1; I : L2													
L3-L2; I : L3													
L1-L2; I : L3													
L2-L3; I : L1													
L3-L1; I : L2													
<b>4. input rated frequency</b> rated frequency 50 Hz													
rated frequency 60 Hz													
9: _____ Hz													
! 9: Nonstandard [Hz]: $10 \leq f_N \leq 400$ by auxiliary voltage from measuring input min. 40 Hz													
<b>5. input rated voltage</b> input voltage $U_N$ : 100 V													
input voltage $U_N$ : 230 V													
9: input voltage $U_N$ : _____ V													
<b>! 3-wire system: <math>U_N</math> = linked voltage</b> ! 9: Nonstandard [V]: $> = 10$ to 690 V by auxiliary voltage from measuring input min. 24 V / max. 230 V, see selection criteria 9, digit 3 and 4													
<b>6. input rated current</b> $I_N$ : 1 A													
$I_N$ : 5 A													
9: $I_N$ : _____ A ( $> 0.5 \dots 6$ A)													
! 9: Nonstandard [A] upon request													
<b>7. measuring range</b> -60 ... 0 ... 60° el													
cos phi : 0.5 ... cap ... 1 ... ind ... 0.5													
9: Nonstandard: _____													
! 1 not to be combined with measuring type order no. 2 ! 2 not to be combined with measuring type order no. 1 ! 9 Nonstandard, measuring range within 1 ... ind ... 0 ... cap ... 1 ... ind ... 0 ... cap ... 1 or -180 ... 0 ... 180° el clear output value, only to 175 ... 0 ... 175° el; measuring range $> = 20^\circ$ el													

Continuation see page 282

## Order Lists

Continuation from page 281

### EMBSIN 271 G - Measuring transducer for phase angle EMBSIN 281 G - Measuring transducer for power factor

Features	Order no.
<b>8. output signal</b>	
0 ... 20 mA	1
4 ... 20 mA	2
9: _____ mA	9
0 ... 10 V	A
Z: _____ V	Z
! 9: Nonstandard [mA]: 0 ... 1.0 to 0 ... < 20 -1.0 ... 0 ... 1.0 to -20 ... 0 ... 20	
1 ... 5 to < (4 ... 20)	
! Z: Nonstandard [V]: 0 ... 1.0 to 0 ... < 10 0.2 ... 1 to 2 ... 10	
-1.0 ... 0 ... 1.0 to -10 ... 0 ... 10	
<b>9. auxiliary voltage</b>	
U <sub>h</sub> : 85 ... 230 V AC/DC	1
U <sub>h</sub> : 24 ... 60 V AC/DC	2
from measuring input (>= 24 ... 60 V AC )	3
from measuring input (>= 85...230 V AC )	4
U <sub>h</sub> : 24 V AC / 24 ... 60 V DC from	5
low voltage side	
U <sub>h</sub> = rated voltage	
tolerances: DC -15 ... +33 %, AC -15 ... +15 %	
! 3 not to be combined with input rated voltage, order-no. 1 and 2	
<b>10. response time</b>	
4 periods of the input frequency	1
2 periods of the input frequency	2
8 periods of the input frequency	3
16 periods of the input frequency	4
! 4 periods = standard	
<b>11. test certificates</b>	
without test certificate	0
with test certificate in German	D
with test certificate in English	E

## Order Lists

### EMBSIN 271 GD – Measuring transducer for phase angle difference

Features	Order no.								
<b>EMBSIN 271 GD, measuring transducer for phase angle-difference</b> order no.: 271 GD - Mxxxxxxx	271 GD -	M	X	X	X	X	X	X	X
<b>1. construction</b> housing MBS, for 35mm DIN rail		M							
<b>2. input rated frequency</b> 50 Hz			1						
60 Hz			2						
9: _____ Hz			9						
! 9: Nonstandard [Hz]: $\geq 10$ to 1500 by auxiliary voltage from measuring input $40 \text{ Hz} \leq f_n \leq 400 \text{ Hz}$									
<b>3. input rated voltage</b> generator and bus bar									
Un : 100 V				1					
Un : 230V				2					
Un : _____ V				9					
3-phase system: Input voltage = linked voltage ! 9: Nonstandard [V]: $\leq 10$ to 690 by auxiliary voltage from measuring input min. 24 V max 230 V ! -> see selection criteria 6, digit 3 and 4									
<b>4. measuring range</b> -120° ... 0° ... +120° el					1				
9: measuring range : _____ ° e					9				
! 9: Nonstandard [°el], measuring range within -10 ... 0 ... 10 to -180 ... 0 ... +180 clear output value, yet only up to -175° ... 0 ... +175° el									
<b>5. output signal</b> 0 ... 20 mA						1			
4 ... 20 mA						2			
9: _____ mA						9			
0 ... 10V						A			
Z: _____ V						Z			
! 9: Nonstandard [mA]: 0 ... 1.00 to 0 ... < 20 -1.0 ... 0 ... 1.00 to -20 ... 0 ... 20 1 ... 5 to < ( 4 ... 20 ) ! Z: Nonstandard [V]: 0 ... 1.0 to 0 ... < 10 0.2 ... 1 to 2 ... 10 -1.0 ... 0 ... 1.0 to -10 ... 0 ... 10									
<b>6. auxiliary voltage</b> Uh: 85 ... 230 V AC/DC							1		
Uh: 24 ... 60 V AC/DC							2		
from measuring input ( $\geq 24 \dots 60 \text{ V AC}$ )							3		
from measuring input ( $\geq 85\dots 230 \text{ V AC}$ )							4		
Uh: 24 V AC / 24 ... 60 V DC from low voltage side Uh = rated voltage tolerances: DC -15 ... +33 %, AC -15 ... +15 % ! 3 and 4 not to be combined with input rated voltage order no. 2							5		
<b>7. response time</b> 4 periods of the input frequency								1	
2 periods of the input frequency								2	
8 periods of the input frequency								3	
16 periods of the input frequency								4	
! 4 periods = standard									
<b>8. test certificates</b> without test certificate									0
with test certificate German									D
with test certificate English									E

## Order Lists

### EMBSIN 351 P – Measuring transducer for active power EMBSIN 361 Q – Measuring transducer for re-active power

Features	Order no.												
<b>EMBSIN 351 P - Measuring transducer for active power</b> order no.: 351 P - Mx xxxxxxxx	351 P-	M	X	X	X	X	X	X		X	X	X	X
<b>EMBSIN 361 Q - Measuring transducer for re-active power</b> order no. : 361 Q - M xxxxxxxxx	361 Q-	M		X	X	X			X	X	X	X	X
<b>1. construction</b> housing MBS, for 35 mm DIN rail		M											
<b>2. Application</b> 3-/4-wire AC current, balanced (U:L1,L2,L3 I:L1)					1								
3-wire AC current, unbalanced					2								
4-phase AC current, unbalanced					3								
<b>3. rated input frequency</b> 50 Hz						1							
60 Hz						2							
<b>4. input rated voltage</b> Un; 100 ... 115 V ; _____ V values to be stated!							1						
Un; 200 ... 230 V ; _____ V							2						
Un; 380 ... 440 V ; _____ V							3						
Un; 600 ... 690 V ; _____ V							4						
Nonstandard Un; _____ V							9						
! 1 ... 4: True effective nominal voltages to be stated													
! 9: Nonstandard [V]: > 115 to < 600													
Un = linked voltage!													
<b>5. input current</b> In: 1 A								1					
In: 5 A								2					
<b>6. measuring range</b> bipolar: _____ W									1				
unipolar: _____ W									2				
measuring range end values to be stated in Watt i.e. 500 W by measuring range bipolar -500 ... 500													
1000 W by measuring range unipolar 0 ... 1000													
permissible end value : 0.75 ... 1.3 x Un x In x $\sqrt{3}$ [ W ]													
bipolar: _____ var										1			
unipolar: _____ var										2			
measuring range end values to be stated in var i.e. 500 var by measuring range bipolar -500 ... 500													
1000 var by measuring range unipolar 0 ... 1000													
permissible end value: 0.5 ... 1.0 x Un x In x $\sqrt{3}$ [var]													
<b>7. output signal, start value</b> bipolar, start value -100 % end value											1		
unipolar, start value 0											2		
live-zero, start value = 20 % end value											3		
! 1 output bipolar not possible with measuring range unipolar measuring range-order no. 2)													
<b>8. output signal, end value</b> end value: 20 mA												1	
end value: 10 mA												2	
end value: 5 mA												3	
end value: 2.5 mA												4	
end value: 10 V												A	
<b>9. auxiliary voltage supply</b> Uh: 85 ... 230 V DC/AC													1
Uh: 24 ... 60 V DC/AC													2
from measuring input ( $\geq$ 85...230 V AC)													4
Uh: 24 V AC / 24 ... 60 V DC													5
connection via low voltage side													
tolerances: DC : -15 ... +33 % ; AC: -15 ... +15 %													
! 4 not to be combined with rated input voltage order-no. 3 and 4													
<b>10. test certificates</b> without test certificate													0
with test certificate German													D
with test certificate English													E

## Order Lists

### EMBSIN 301 – Measuring transducer for alternating current / RMS effective value measuring

auxiliary voltage 230 V AC

auxiliary voltage 24 V DC

Order no.	Measuring range
137112	30 / 15 A
137113	40 / 20 A
137114	50 / 25 A
137115	60 / 30 A
137117	100 / 50 A
137118	150 / 75 A
137119	200 / 100 A
137120	250 / 125 A
137121	300 / 150 A
137122	400 / 200 A
137123	500 / 250 A
137124	600 / 300 A

Order no.	Measuring range
137212	30 / 15 A
137213	40 / 20 A
137214	50 / 25 A
137215	60 / 30 A
137217	100 / 50 A
137218	150 / 75 A
137219	200 / 100 A
137220	250 / 125 A
137221	300 / 150 A
137222	400 / 200 A
137223	500 / 250 A
137224	600 / 300 A

### EMBSIN 391 PV – Programmable measuring transducer for all electrical parameters

Features	Order no.											
EMBSIN 391 PV, programmable measuring transducer for all electrical parameters order no.: 391 P - Vxxxxxxx	391 P -	V	X	X	X	X	X	X	X	X	X	X
<b>1. application</b>												
single-phase alternating current			1									
3-wire direct current, balanced			2									
3-wire direct current, unbalanced			3									
4-wire direct current, balanced			4									
4-wire alternating current, unbalanced			5									
<b>2. nominal range of the input voltage</b>												
<b>input voltage direct connection</b>												
<b>input voltage via voltage transformer</b>				A								
0 ... 50 V AC (linked voltage!) please state value!						1						
0 ... 500 V AC (linked voltage!) please state value!						2						
<b>3. nominal value of the input current</b>												
input current via current transformer							B					
0 ... 0.5 A AC, please state value!								1				
0 ... 5.0 A AC, please state value!								2				
<b>4. auxiliary voltage</b>												
universal power supply (24 ... 300 V DC/ 40 ... 276 V AC )									1	0		
AC-voltage supply (!) <b>(!) units with this type of auxiliary voltage supply have only one analogue measuring output</b>												
AC-voltage supply										2		
57.74 V AC											1	
63.5 V AC											2	
100 V AC											3	
110 V AC											4	
230 V AC											5	
250 V AC											6	
400 V AC											7	
500 V AC											8	
<b>5. type of serial interface</b>												
RS232												1
RS485												2
<b>6. state upon delivery</b>												
transmission parameters are not set												0
parameters are arranged acc. to customer specification												1

Continuation see page 286

## Order Lists

Continuation from page 285

### ordering schedule 1

### EMBSIN 391 PV – Programmable measuring transducer for all electrical parameters

Description	Code	
<b>measuring volume</b>		
<b>true-rms-current</b>		
<b>application</b>		
single-phase alternating current	L	I <sub>1</sub> , I <sub>2</sub> , I <sub>3</sub>
alternating current, three-phase system	L <sub>1</sub> , L <sub>2</sub> or L <sub>3</sub>	I <sub>N</sub> or I
measuring range	0 ... 0.5 A to 0 ... 5 A	_____ A
<b>true-rms-voltage</b>		
single-phase alternating current	U	_____
	phase to N	
	U <sub>1</sub> , U <sub>2</sub> or U <sub>3</sub>	
alternating current	linked voltage	_____
	U <sub>1</sub> -U <sub>2</sub> , U <sub>2</sub> -U <sub>3</sub> or U <sub>3</sub> -U <sub>1</sub>	
measuring range	0 ... 50 V to 0 ... 500 V	0 - _____ V
<b>frequency</b>		
all connections	system frequency	_____ Hz
measuring range	45Hz ≤ f ≤ 65 Hz (f <sub>1</sub> ≤ f ≤ f <sub>2</sub> )	__ ≤ f ≤ __ Hz
<b>phase angle</b>		
single-phase alternating current		
alternating current, three-phase system	φ <sub>1</sub> , φ <sub>2</sub> , φ <sub>3</sub> (U - I) φ <sub>12</sub> , φ <sub>13</sub> , φ <sub>23</sub> (U <sub>1</sub> -U <sub>2</sub> , U <sub>1</sub> -U <sub>3</sub> , U <sub>2</sub> -U <sub>3</sub> ) average value φ	
measuring range	-180° ≤ φ ≤ 180° defined range (φ <sub>1</sub> ≤ φ ≤ φ <sub>2</sub> )	
<b>power factor</b>		
single-phase alternating current	PF	
alternating current	PF <sub>1</sub> , PF <sub>2</sub> or PF <sub>3</sub> PF total supply network	
measuring range	-1 ≤ PF ≤ +1 defined range	
<b>active power</b>		
single-phase alternating current	P	
alternating current, three-phase system	P <sub>1</sub> , P <sub>2</sub> or P <sub>3</sub> P-total	_____ W _____ W
measuring range	dependent on input value U, I (+/-) ... W	
<b>re-active power</b>		
single-phase alternating current	Q	
alternating current, three-phase system	Q <sub>1</sub> , Q <sub>2</sub> or Q <sub>3</sub> Q-total	_____ var _____ var
measuring range	dependent on input value U, I (+/-) ... var	

## Order Lists

### ordering schedule 2

### EMBSIN 391 PV – Programmable measuring transducer for all electrical parameters

Description	Code	
<b>measuring volume</b>		
<b>apparent power (VA)</b>		
single-phase alternating current	S	_____
alternating current, three-phase system	S <sub>1</sub> , S <sub>2</sub> or S <sub>3</sub> S total	_____
measuring range	dependent on value U, I (+/-) ... VA	___VA ... ___VA
<b>retrievable available values</b>		
current phases I <sub>1</sub> , I <sub>2</sub> , I <sub>3</sub>	I <sub>1</sub> , I <sub>2</sub> or I <sub>3</sub>	DDI <sub>1</sub> , DDI <sub>2</sub> , DDI <sub>3</sub>
mean value of the total apparent power	S total	DDSt
total active power	P-total positive P-total negative	DDPt+ DDPt-
total re-active power	Q-total -L Q-total +C	DDQtL DDQtC
measuring range	dependent on the type of inquiry	
<b>type of output characteristic</b>		
type of output characteristic	linear curved (1)	L B
(1) when ordering curved output characteristics please refer to the additional information in table 3		
<b>outputs</b>		
start value of the output signals	-20 mA ≤ I ≤ +20 mA current -10 V ≤ U ≤ +10 V voltage	_____mA _____V
output value	0 ... 20 mA current output 0 ... 10 V voltage output	_____mA _____V
standard output values		0 ... 1 mA 0 ... 5 mA 0 ... 10 mA 0 ... 20 mA 4 ... 20 mA -1 ... 0 ... +1 mA -10 ... 0 ... +10 mA -20 ... 0 ... +20 mA 0 ... 10 V -1 ... 0 ... +1 V -10 ... 0 ... +10 V

All output signals are limited to 120 % of the rated nominal value

### ordering schedule 3

### EMBSIN 391 PV - Programmable measuring transducer for all electrical parameters

Table 3

#### Additional information when ordering measuring transducers with curved output characteristics

When ordering measuring transducers with curved characteristics the start and end points as well as the position of the required curved break of the to be adjusted transmission ratio have to be defined. Measuring transducers of the type **EMBSIN 391 PV** allow the presentation of transmission characteristics of up to 5 curved breaks .

Description	Code	
start value of the measuring value (s)	dependent on measuring range s	
start value of the output value	-20 mA ... +20 mA/ -10 V ... +10 V dependent on output range -20 ≤ p ≤ +20/ -10 ≤ p ≤ +10	p
end value of the measuring value (e)	dependent on measuring range	
end value of the output value (rt) if measuring value (e)	-20 mA ... +20 mA/ -10 V ... +10 V dependent on output range	rt
value of the measuring value (n <sub>x</sub> )	dependent on measuring range	
value of the output value (o <sub>x</sub> ) if measuring value (n <sub>x</sub> )	-20 mA ... +20 mA/ -10 V ... +10 V dependent on output range -20 ≤ p ≤ +20/ -10 ≤ p ≤ +10	n <sub>1</sub> ... n <sub>5</sub> o <sub>1</sub> ... o <sub>5</sub>

**Ordering example:**

The measuring transducer EMBSIN 391 PV is installed into a 4-wire alternating current supply network with balanced phase-loads. The measuring transducer is connected via a voltage transformer 100/0.11 kV as well as to a current transformer of 200/5 A. The auxiliary voltage supply of the measuring transducer is effected by means of an integrated power unit. For the communication an interface of RS485 is required. The following measuring values must be included in the measuring feeds:

Output 1	
total output of the system	-40 ... +40 MW
output current	-20...+20 mA
transmission ratio	linear

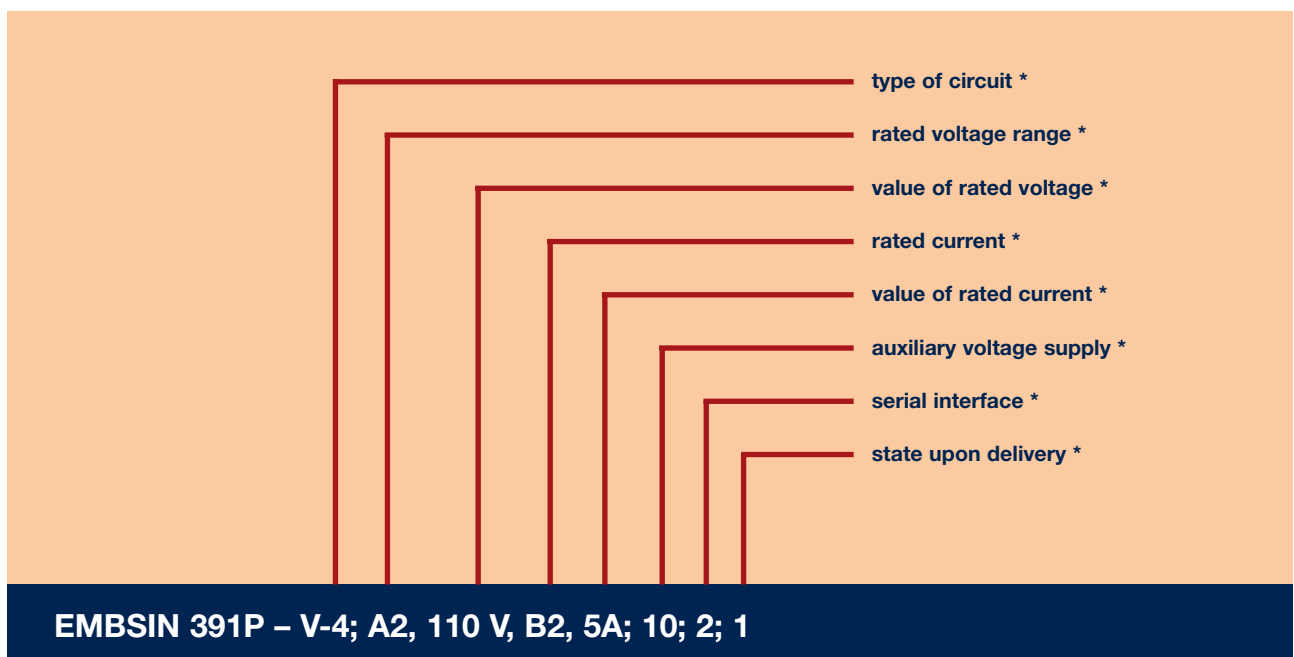
  

Output 2	
measuring value	phase angle
output voltage	0 ... 10 V
	start value: $-180^\circ = -10\text{ V}$
	curved point: $0^\circ = 10\text{ V}$
	end value: $179.9^\circ = 10\text{ V}$

Output 3	
measuring value	system frequency 45 ... 55 Hz
current output	0 ... 20 mA
	48 Hz = 2 mA
	52 Hz = 18 mA
	55 Hz = 20 mA

Ordering text: **EMBSIN 391 P - V-4; A2, 110 V; B2, 5 A; 10; 2, 1**  
 output 1: **P $\pm$  40 MW; L; -20...200 mA**  
 output 2:  **$\varphi \pm 180^\circ$ ; B; (180/-10; 0/0; 180/10)**  
 output 3: **f 45...55 Hz; B; (45/0, 48/2, 52/18, 55/20)**



\* order code of table 1, page 285

## Standard Units

<b>EMBSIN 100 I</b>	Measuring transducer for AC current, without auxiliary voltage supply . . . . .	290
<b>EMBSIN 101 I</b>	Measuring transducer for AC current, with auxiliary voltage supply . . . . .	290
<b>EMBSIN 201 IE</b>	Measuring transducer for AC current, rms measurement . . . . .	290
<b>EMBSIN 120 U</b>	Measuring transducer for AC voltage, without auxiliary voltage supply . . . . .	290
<b>EMBSIN 121 U</b>	Measuring transducer for AC voltage, with auxiliary voltage supply . . . . .	291
<b>EMBSIN 221 UE</b>	Measuring transducer for AC voltage, rms measurement . . . . .	291
<b>EMBSIN 241 F</b>	Measuring transducer for frequency for universal AC/DC power supply. . . . .	291
<b>EMBSIN 281 G</b>	Measuring transducer for power factors, with universal AC/DC power supply. . . . .	291
<b>EMBSIN 351 P</b>	Measuring transducer for active power, with universal AC/DC power supply. . . . .	292
<b>EMBSIN 361 Q</b>	Measuring transducer for re-active power, with universal AC/DC power supply . . . . .	292

## Standard Units

### EMBSIN 100 I Measuring transducer for alternating current, without auxiliary voltage, with 2 measuring ranges

Construction	Rated frequency	Measuring range	Output signal	Art.-no.
		0 ... 1.0 A / 5 A	0 ... 5 mA	127 698
housing		0 ... 1.0 A / 5 A	0 ... 10 mA	127 705
MBS	50/60 Hz	0 ... 1.0 A / 5 A	0 ... 20 mA	127 713
for 35 mm		0 ... 1.2 A / 6 A	0 ... 5 mA	127 721
DIN rail		0 ... 1.2 A / 6 A	0 ... 10 mA	127 739
		0 ... 1.2 A / 6 A	0 ... 20 mA	127 747

### EMBSIN 101 I Measuring transducer for alternating current, with auxiliary voltage

Construction	Rated frequency	Measuring range	Output signal	Auxiliary voltage	Art.-no.
		0 ... 1 A	0 ... 20 mA	230 V AC	128 290
		0 ... 5 A	0 ... 20 mA	230 V AC	128 307
housing		0 ... 1 A	4 ... 20 mA	230 V AC	128 331
MBS	50/60 Hz	0 ... 5 A	4 ... 20 mA	230 V AC	128 349
for 35 mm		0 ... 1 A	0 ... 20 mA	24 V DC	128 315
DIN rail		0 ... 5 A	0 ... 20 mA	24 V DC	128 323
		0 ... 1 A	4 ... 20 mA, 2-wire	24 V DC	128 357
		0 ... 5 A	4 ... 20 mA, 2-wire	24 V DC	128 365

### EMBSIN 201 IE Measuring transducer for alternating current, with auxiliary voltage, with 2 measuring ranges, effective value measuring

Construction	Rated frequency	Measuring range	Output signal	Auxiliary voltage DC or AC 40...400 Hz	Art.-no.
housing		0 ... 1.0 A / 5 A	0 ... 20 mA		128 232
MBS		0 ... 1.0 A / 5 A	4 ... 20 mA	85 ... 230 V	128 240
for 35 mm	50/60 Hz	0 ... 1.2 A / 6 A	0 ... 20 mA		128 258
DIN rail		0 ... 1.2 A / 6 A	4 ... 20 mA		128 266

Response time of the output value: 300 ms

### EMBSIN 120 U Measuring transducer for alternating voltage, without auxiliary voltage supply

Construction	Rated frequency	Measuring range	Output signal	Art.-no.
		0 ... 100 / $\sqrt{3}$ V	0 ... 5 mA	127 854
		0 ... 100 / $\sqrt{3}$ V	0 ... 20 mA	127 862
		0 ... 110 / $\sqrt{3}$ V	0 ... 5 mA	127 870
		0 ... 110 / $\sqrt{3}$ V	0 ... 20 mA	127 888
housing		0 ... 100 V	0 ... 5 mA	127 896
MBS		0 ... 100 V	0 ... 20 mA	127 903
for 35 mm	50/60 Hz	0 ... 110 V	0 ... 5 mA	127 911
DIN rail		0 ... 110 V	0 ... 20 mA	127 929
		0 ... 120 V	0 ... 5 mA	127 953
		0 ... 120 V	0 ... 20 mA	127 961
		0 ... 250 V	0 ... 5 mA	127 937
		0 ... 250 V	0 ... 20 mA	127 945
		0 ... 500 V	0 ... 5 mA	127 979
		0 ... 500 V	0 ... 20 mA	127 987

## Standard Units

### EMBSIN 121 U Measuring transducer for alternating voltage, with auxiliary voltage supply

Construction	Rated frequency	Measuring range	Output signal	Auxiliary voltage	Art.-no.
		0 ... 100 V	0 ... 20 mA	230 V AC	127 341
		0 ... 250 V	0 ... 20 mA	230 V AC	127 359
housing		0 ... 500 V	0 ... 20 mA	230 V AC	127 383
MBS	50/60 Hz	0 ... 100 V	0 ... 20 mA	24 V DC	127 367
for 35 mm		0 ... 250 V	0 ... 20 mA	24 V DC	127 375
DIN rail		0 ... 100 V	4 ... 20 mA, 2-wire	24 V DC	127 391
		0 ... 250 V	4 ... 20 mA, 2-wire	24 V DC	127 408
		0 ... 500 V	4 ... 20 mA, 2-wire	24 V DC	127 416

### EMBSIN 221 UE Measuring transducer for alternating voltage, with auxiliary voltage supply, effective value measuring

Construction	Rated frequency	Measuring range	Output signal	Auxiliary voltage DC or AC 40...400 Hz	Art.-no.
		0 ... 100 V	0 ... 20 mA		127 440
		0 ... 100 V	4 ... 20 mA		127 458
housing		0 ... 120 V	0 ... 20 mA		127 466
MBS	50/60 Hz	0 ... 120 V	4 ... 20 mA	85 ... 230 V	127 474
for 35 mm		0 ... 250 V	0 ... 20 mA		127 507
DIN rail		0 ... 250 V	4 ... 20 mA		127 515
		0 ... 500 V	0 ... 20 mA		127 482
		0 ... 500 V	4 ... 20 mA		127 490

response time of the output signal: 300 ms

### EMBSIN 241 F Measuring transducer for frequency, with auxiliary voltage supply

Construction	Input voltage	Measuring range	Output signal	Auxiliary voltage DC or AC 40...400 Hz	Art.-no.
		45 ... 55 Hz	0 ... 20 mA		127 549
	10 ... 230 V	45 ... 55 Hz	4 ... 20 mA		127 557
housing		48 ... 52 Hz	0 ... 20 mA		127 573
MBS		48 ... 52 Hz	4 ... 20 mA	85 ... 230 V	127 565
for 35 mm		45 ... 55 Hz	0 ... 20 mA		127 581
DIN rail	230 ... 690 V	45 ... 55 Hz	4 ... 20 mA		127 606
		48 ... 52 Hz	0 ... 20 mA		127 599
		48 ... 52 Hz	4 ... 20 mA		127 614

response time of the output volume: 4 periods of the input frequency

### EMBSIN 281 G Measuring transducer for active power factor, with auxiliary voltage supply

Construction	Input volumes	Output signal	Application	Auxiliary voltage DC or AC 40...400 Hz	Art.-no.
housing	230 V AC (L1-N)	0 ... 20 mA	single-phase		127 648
MBS	and 5 A (L1)	4 ... 20 mA	alternating current	85 ... 230 V	127 664
for 35 mm	400 V AC (L1-L2)	0 ... 20 mA	3- or 4-wire		127 656
DIN rail	and 5 A (L1)	4 ... 20 mA	direct current, balanced load		127 672

response time of the output volume: 4 periods of the input frequency  
 rated frequency of the input volume: 50 Hz  
 measuring range: 0.5...cap...1...ind...0.5 cos phi  
 output volume: proportional cos phi

## Standard Units

### EMBSIN 351 P Measuring transducer for active power, with auxiliary voltage supply

Construction	Measuring inputs	Output signal	Application	Auxiliary voltage DC or AC 40...400 Hz	Art.-no.
housing	$U_n$ : L <sub>1</sub> , L <sub>2</sub> , L <sub>3</sub> $I_n$ : L <sub>1</sub>	4 ... 20 mA	3-wire direct current balanced load		137 770
MBS for 35 mm DIN rail	$U_n$ : L <sub>1</sub> , L <sub>2</sub> , L <sub>3</sub> $I_n$ : L <sub>1</sub> and L <sub>3</sub>	4 ... 20 mA	3-wire direct current unbalanced load	85 ... 230 V	137 788
	$U_n$ : L <sub>1</sub> , L <sub>2</sub> , L <sub>3</sub> $I_n$ : L <sub>1</sub> , L <sub>2</sub> , L <sub>3</sub>	4 ... 20 mA	4-wire direct current unbalanced load		137 796

input rated voltage  $U_n$ : 400 V (linked voltage!)  
 input rated current: 5 A  
 rated frequency measuring input: 50 Hz  
 measuring range: 0 ... 2 kvar

### EMBSIN 361 Q Measuring transducer for re-active power, with auxiliary voltage supply

Construction	Measuring inputs	Output signal	Application	Auxiliary voltage DC or AC 40...400 Hz	Art.-no.
housing					
MBS for 35 mm DIN rail	$U_n$ : L <sub>1</sub> , L <sub>2</sub> , L <sub>3</sub> $I_n$ : L <sub>1</sub> and L <sub>3</sub>	4 ... 20 mA	3-wire alternating current unbalanced load	85 ... 230 V	137 803

input rated voltage  $U_n$ : 400 V (linked voltage!)  
 input rated current: 5 A  
 rated frequency measuring input: 50 Hz  
 measuring range: 0 ... 2 kvar

## Electronic energy meter for industrial applications

### Single-phase energy meter, direct measuring, clip-on to 35 mm DIN rail

					page
ECP6112	2-wire	1 S0-impulse output	kWh	5 (32) A	...294
ECP6152	2-wire	1 S0-impulse output, LCD	kWh	5 (32) A	...295
EMU6114	2-wire	1 S0-impulse output	kWh	5 (63) A	...296
EMU6124	2-wire	1 S0-impulse output	2 tariffs kWh	5 (63) A	...297

### Single-phase energy and power meter, direct measuring (suitable for socket)

EMU6557	2-wire	cable connection	kWh	16 A	...298
EMU6657	2-wire	suitable for socket	kWh	16 A	...299

### Three-phase energy meter, direct measuring, clip-on to 35 mm DIN rail

EEH1116	4-wire	1 S0-impulse output	kWh / kvarh	10 (63) A	...300
EEH1126	4-wire	1 S0-impulse output	2 tariffs +/-kWh / kvarh	10 (63) A	...301
EEH1176	4-wire	1 S0-impulse output, LCD	2 tariffs +/-kWh / kvarh	10 (63) A	...302
EEH2116	3-wire	1 S0-impulse output	kWh / kvarh	10 (63) A	...303
EEH2126	3-wire	1 S0-impulse output	2 tariffs +/-kWh / kvarh	10 (63) A	...304
EEH2176	3-wire	1 S0-impulse output, LCD	2 tariffs +/-kWh / kvarh	10 (63) A	...305

### Three-phase energy transformer meter, clip-on to 35 mm DIN rail

EEH1115	4-wire	1 S0-impulse output	kWh / kvarh	5 A, 1 A	...306
EEH1125	4-wire	1 S0-impulse output	2 tariffs +/-kWh / kvarh	5 A, 1 A	...307
EEH1175	4-wire	1 S0-impulse output, LCD	2 tariffs +/-kWh / kvarh	5 A, 1 A	...308
EEH2115	3-wire	1 S0-impulse output	kWh / kvarh	5 A, 1 A	...309
EEH2125	3-wire	1 S0-impulse output	2 tariffs +/-kWh / kvarh	5 A, 1 A	...310
EEH2175	3-wire	1 S0-impulse output, LCD	2 tariffs +/-kWh / kvarh	5 A, 1 A	...311
EWS1915	4-wire	with relay impulse output	+/-kWh / kvarh	5 A, 1 A	...312
EWS1945	4-wire	with relay impulse output	2 electro-mechanical counters +/-kWh / kvarh	5 A, 1 A	...313
EWS1995	4-wire	with relay impulse output, LCD	2 electro-mechanical counters +/-kWh / kvarh	5 A, 1 A	...314

### Three-phase energy transformer meter for front panel mounting, 96 x 96 mm

EWQ1915	4-wire	with relay impulse output	+/-kWh / kvarh	5 A, 1 A	...315
EWQ1945	4-wire	with relay impulse output	2 electro-mechanical counters +/-kWh / kvarh	5 A, 1 A	...316
EWQ1995	4-wire	with relay impulse output, LCD	2 electro-mechanical counters +/-kWh / kvarh	5 A, 1 A	...317



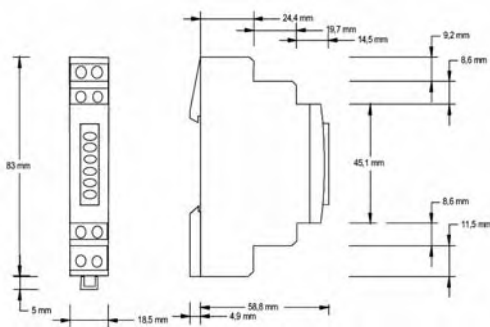
# ECP6112

Single-phase energy meter,  
direct measuring

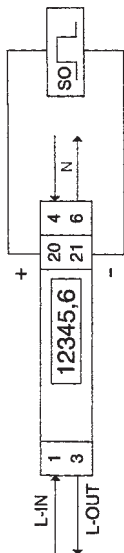


AC energy meter for clip-on to 35 mm DIN rail

drawing



connection diagram



<b>Type of energy meter</b>	<b>ECP6112</b>	
<b>Mains</b>	2-wire rated voltage $U_N$ tolerance value: frequency	L-N (230 V) 230 V -30 %...+30 % 50 Hz
<b>Output</b>	1 S0-impulse output optocoupler output impulse connection terminal	max. 27 V DC / 10 up to 27 mA 1000 Imp/kWh 20, 21
<b>Counter</b>	1 counter meter for active energy (kWh) electro-mechanical meter number of digits digit height digit width function control	6 (5.1 digits) 4 mm 2 mm flashing LED 1000 Imp/kWh
<b>Current range</b>	5 (32) A nominal current $I_N$ max. current ( $I_{max}$ ) start current energy consumption	5 A 32 A 0.004 $I_N$ 0.4 W

<b>Technical data</b>	accuracy class ambient temperature connections dimensions (mm) weight	class 1 -25 °C to +55 °C 1...6 mm <sup>2</sup> 18.6 x 91 x 64 0.08 kg
-----------------------	---	---

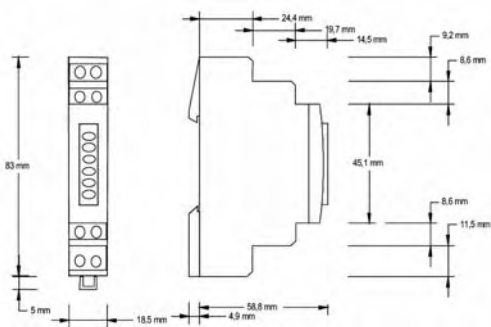


# ECP6152

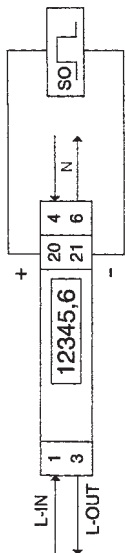
Single-phase energy meter,  
direct measuring

AC energy meter for clip-on to 35 mm DIN rail

drawing



connection diagram



**Type of energy meter** ECP6152

<b>Mains</b>	2-wire	L-N (230 V)
	rated voltage $U_N$	230 V
	tolerance value:	-30 %...+30 %
	frequency	50 Hz

<b>Output</b>	1 S0-impulse output	
	optocoupler	max. 27 V DC / 10 up to 27 mA
	output impulse	1000 Imp/kWh
	connection terminal	20, 21

<b>Counter</b>	LCD counter meter for active energy (kWh)	
	LCD counter meter	
	number of digits	6 (5.1 digits)
	digit height	4 mm
	digit width	2 mm
function control	flashing LED 1000 Imp/kWh	

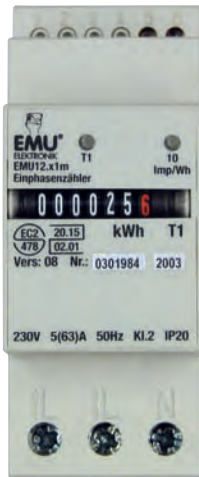
<b>Current range</b>	5 (32) A	
	nominal current $I_N$	5 A
	max. current ( $I_{max}$ )	32 A
	start current	0.004 $I_N$
	energy consumption	0.4 W

**Technical data**

accuracy class	class 1
ambient temperature	-25 °C to +55 °C
connections	1...6 mm <sup>2</sup>
dimensions (mm)	18.6 x 91 x 64
weight	0.08 kg

# EMU6114

## Single-phase energy meter



AC energy meter for clip-on to 35 mm DIN rail  
 These energy meters are suitable for calibration.

**Type of energy meter** EMU12.x1m

<b>Mains</b>	2-wire	L-N (230 V)
	rated voltage $U_N$	230 V
	tolerance value	-20 %...+20 %
	frequency	50 Hz
	frequency range	45...65 Hz

**Output** 1 SO-impulse output

(S0+ / S0-) collector open	optocoupler	5-30 V DC / 20 mA max.
	impulse duration	125 ms
	output impulse	10 Imp/kWh
	impedance	0.5 – 1.5 kOhm
	connection terminal	5 / 6

**Counter** 1 counter meter for active energy (kWh)

electro-mechanical meter	
number of digits	7 (6.1 digits)
digit height	4 mm
digit width	1.2 mm
operating display	green LED
LED test	10 Imp/Wh (invisible)

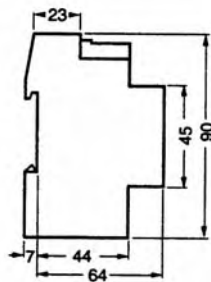
**Current range** 5 (63) A

nominal current $I_N$	5 A
max. current ( $I_{max}$ )	63 A
consumption	0.8 W
start current	0.005 $I_N$

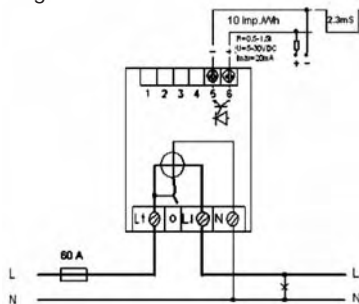
**Technical data**

approbations	PTB approval
accuracy class	class 2, DIN EN 61036, active energy
ambient temperature	-10 °C to +50 °C
protection class	
housing	IP 51
main connections	1 ... 10 mm <sup>2</sup>
SO-impulse output	max. 2.5 mm <sup>2</sup>
dimensions (mm)	36 x 90 x 71
weight	0.15 kg

drawing



diagram

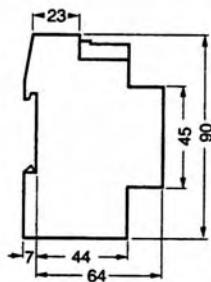


# EMU6124

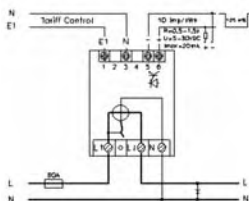


AC energy meter for clip-on to 35 mm DIN rail  
 These energy meters are suitable for calibration.

drawing



diagram



<b>Type of energy meter</b>	EMU12.x1m	
-----------------------------	-----------	--

<b>Mains</b>	2-wire	L-N (230 V)
	rated voltage $U_N$	230 V
	tolerance value	-20 %...+20 %
	frequency	50 Hz
	frequency range	45...65 Hz

<b>Output</b> (S0+/S0-) collector open	1 S0-impulse output	
	optocoupler	5-30 V DC / 20 mA max.
	impulse duration	125 ms
	output impulse	10 Imp/kWh
	impedance	0.5 – 1.5 kOhm
	connection terminal	5 / 6

<b>Counter</b>	2 counter meters for active energy HT-NT (kWh)	
	2 electro-mechanical meters	
	number of digits	7 (6.1-digits)
	digit height	4 mm
	digit width	1.2 mm
	operating display	green LED (active tariff)
	LED test	10 Imp/Wh (invisible)

<b>Current range</b>	5 (63) A	
	nominal current $I_N$	5 A
	max. current ( $I_{max}$ )	63 A
	consumption	0.8 W
	start current	0.005 $I_N$

<b>Technical data</b>	approbations	PTB approval
	accuracy class	class 2, DIN EN 61036, active energy
	ambient temperature	-10 °C to +50 °C
	protection class	
	housing	IP 51
	main connections	1 ... 10 mm <sup>2</sup>
	S0-impulse output	max. 2.5 mm <sup>2</sup>
	dimensions (mm)	36 x 90 x 71
	weight	0.17 kg
	tariff control	230 V AC
	Tariff 2 is energized when terminals 1 and 3 are under load of 230 V AC.	



# EMU6557

## Single-phase energy meter

Socket meter

<b>Type of energy meter</b>	EMU1.x4	
<b>Mains</b>	2-wire	L-N (230 V)
	rated voltage $U_N$	176 - 264 V
	frequency	50 Hz
	frequency range	45...65 Hz
<b>Output</b>	cable connection	
<b>Counter</b>	LCD counter for active energy	
	continuous active energy Wh/kWh	
	price per kWh	
	total energy costs	
	present active power W/kW	
	present voltage V	
	present current supply A	
	number of digits	4 (3.1 digits)
	digit height	13 mm
	digit width	7.5 mm
function control	display test in all functions during start	
<b>Current range</b>	16 A	
	nominal current $I_N$	16 A
	start current	10 mA
<b>Technical data</b>	accuracy class	class 2, IEC 348; IEC 1036, active energy
	ambient temperature	-10 °C to +50 °C
	protection class	1 IP 20
	connection	0.01 - 16 A (euro-plug)
	dimensions (mm)	130 x 67 x 73
	weight	0.36 kg
	cable length	1.00 m



# EMU6657

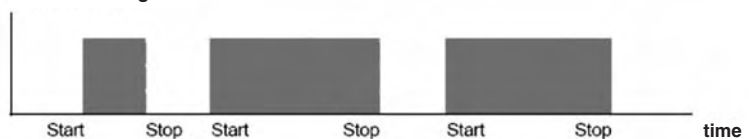
## Single-phase energy meter

Socket meter

<b>Type of energy meter</b>		EMU-Check
<b>Mains</b>	2-wire	L-N (230 V)
	rated voltage $U_N$	140 - 264 V
	frequency	50 Hz
	frequency range	45...65 Hz
<b>Output</b>		socket
<b>Counter</b>		LCD counter for active energy continuous active power Wh/kWh level (adjusted starting value in kW) time (total time via level in h) present active power W/kW present voltage V present current supply A present power factor number of digits 6 (5.1 digits) digit height 7 mm digit width 3.5 mm function control display test in all functions during start
<b>Current range</b>		16 A
	nominal current $I_N$	16 A
	start current	10 mA
<b>Technical data</b>		accuracy class class 2, IEC 1036, active energy ambient temperature -10 °C to +50 °C protection class 1 IP 20 connections 0.01 - 16 A (euro-plug) dimensions (mm) 130 x 67 x 73 weight 0.15 kg



time measuring



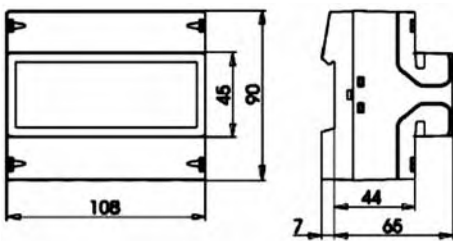


# EEH1116

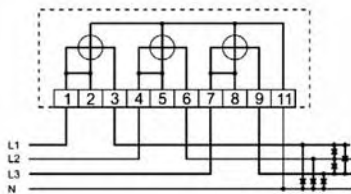
## Three-phase energy meter

AC energy meter for clip-on to 35 mm DIN rail

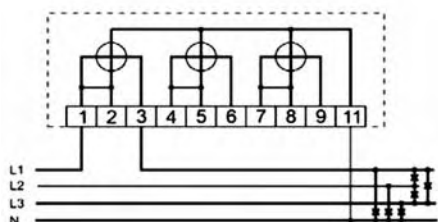
drawing



diagram



Option EEH5116  
equally load phases



### Type of energy meter EEH1116

<b>Mains</b>	4-wire	L-N (230 V)
	rated voltage $U_N$	230 V
	tolerance value	-20 %...+15 %
	consumption	< 3.0 W/phase
	frequency	50 Hz
	frequency range	45...65 Hz

### Output 1 S0-impulse output

(S0)	optocoupler	40 V / 27 mA max.
collector open	impulse duration	100 ms +/-50 %
	output impulse	1000 Imp/kWh
	connection terminal	40 / 41

(option)	communication	RS485	EEH1316
	connection		multi-drop
	cable type		screened, wound pair
	max. cable length		1000 m
	connection		terminal screw
	isolation		3.7 kV rms for 1 min. between all meters and other units
	transmission system		asynchronous
	format type		MODBUS RTU
	transmission time		1200 to 19200 bits/s
	connection A and B		120 Ohm
	max. linked meters		32

### Counter 1 counter meter for active energy (kWh)

	electro-mechanical meter	
	number of digits	7 (6.1 digits)
	digit height	4 mm
	digit width	1.2 mm
	LED test	1000 Imp/kWh (red)
	LED operation	status (red)

### (option) 1 meter for reactive energy (kvarh) EEH1106

### Current range 10 (63) A

	nominal current $I_N$	10 A
	max. current $I_{max}$	63 A
	consumption	< 0.02 W/phase
	start current	0.004 $I_N$

### Technical data

approbations	active energy	EN 61036	class 1
	reactive energy	EN 61268	class 2
construction	housing	PA6.6 in conformity with UL 94 V-0	
	dimensions (mm)	108 x 90 x 72	
	weight	0.6 kg	
	mounting	DIN rail acc. to DIN EN 50022	
ambient temperature	climatic conditions	EN 61036	interior meter
	operation	-20 °C to +55 °C	
	storage	-25 °C to +70 °C	
	protection class	2	
	current terminals	< 16 mm <sup>2</sup>	
	control terminals	< 2.5 mm <sup>2</sup>	

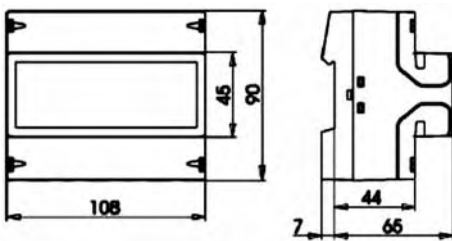


# EEH1126

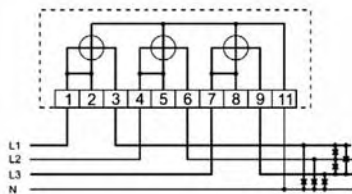
## Three-phase energy meter

AC energy meter for dual tariff, suitable for clip-on to 35 mm DIN rail

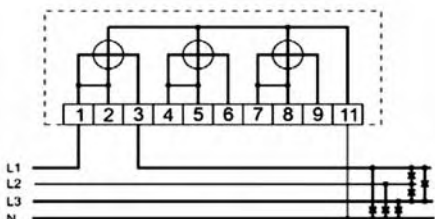
drawing



diagram



Option EEH5226  
equally load phases



### Type of energy meter EEH126

<b>Mains</b>	4-wire	L-N (230 V)
	rated voltage $U_N$	230 V
	tolerance value	-20 %...+15 %
	consumption	< 3.0 W/phase
	frequency	50 Hz
	frequency range	45...65 Hz

### Output 1 S0-impulse output

(S0)	optocoupler	40 V / 27 mA max.
collector open	impulse duration	100 ms +/- 50 %
	output impulse	1000 Imp/kWh
	connection terminal	40 / 41 / 42

### (option) communication

RS485 connection	EEH1426
cable type	multi-drop
max. cable length	screened, wound pair
connection	1000 m
isolation	terminal screw
	3.7 kV rms for 1 min. between all meters and other units
transmission system	asynchronous
format type	MODBUS RTU
transmission time	1200 to 19200 bits/s
connection A and B	120 Ohm
max. linked meters	32

### Counter 2 counter meters for active energy HT-NT (kWh)

	2 electro-mechanical meters	
	number of digits	7 (6.1 digits)
	digit height	4 mm
	digit width	1.2 mm
	LED test	1000 Imp/kWh (red)
	LED operation	status (tariffs) (red)

(option)	2 meters for active/reactive energy (kvarh)	EEH1236
	2 meters for active energy (import/export) (kWh)	EEH1246

### Current range 10 (63) A

	nominal current $I_N$	10 A
	max. current $I_{max}$	63 A
	consumption	< 0.02 W/phase
	start current	0.004 $I_N$

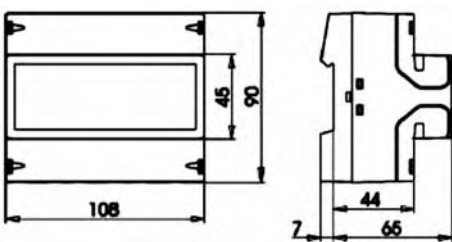
### Technical data

	approbations	EN 61036	class 1
	active energy	EN 61268	class 2
construction	reactive energy		
	housing	PA6.6 in conformity with UL 94 V-0	
	dimensions (mm)	108 x 90 x 72	
	weight	0.6 kg	
	mounting	DIN rail acc. to DIN EN 50022	
	climatic conditions	EN 61036	interior meter
ambient temperature	operation	-20 °C to +55 °C	
	storage	-25 °C to +70 °C	
	protection class	2	
	current terminals	< 16 mm <sup>2</sup>	
	control terminals	< 2.5 mm <sup>2</sup>	
	tariff start	230 V AC	
	Tariff 2 is energized when terminals 13 and 15 are under load of 230 V AC.		

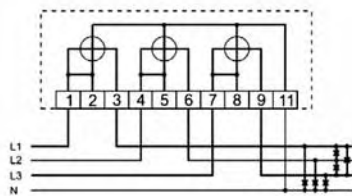


photo is similar to the original

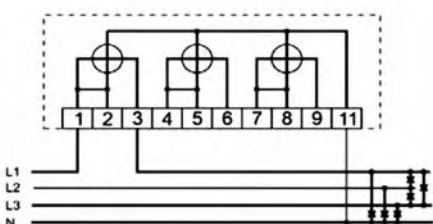
drawing



diagram



Option EEH5276  
equal load phases



# EEH1176

## Three-phase energy meter

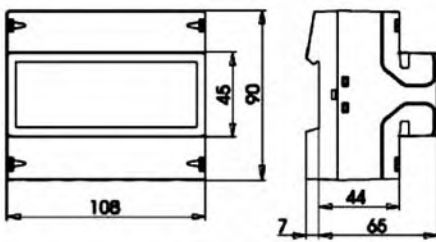
AC energy meter for dual tariff, suitable for clip-on to 35 mm DIN rail

<b>Type of energy meter</b>		EEH1176
<b>Mains</b>		4-wire L-N (230 V) rated voltage $U_N$ 230 V tolerance value -20 %...+15 % consumption < 3.0 W/phase frequency 50 Hz frequency range 45...65 Hz
<b>Output</b>		1 S0-impulse output optocoupler 40 V / 27 mA max. impulse duration 100 ms +/-50 % collector open output impulse 1000 Imp/kWh connection terminal 40 / 41
<b>(option) communication</b>		RS485 connection multi-drop cable type screened, wound pair max. cable length 1000 m connection terminal screw isolation 3.7 kV rms for 1 min. between all meters and other units transmission system asynchronous format type MODBUS RTU transmission time 1200 to 19200 bits/s connection A and B 120 Ohm max. linked meters 32
<b>Counter</b>		LCD counter meter for active energy HT-NT (kWh) LCD counter number of digits 2 x 9 (8.1 digits) digit height 4.86 mm digit width 2.96 mm
<b>(option)</b>		2 meters for active/reactive energy (kvarh) EEH1286 2 meters for active energy (import/export) (kWh) EEH1296
<b>Current range</b>		10 (63) A nominal current $I_N$ 10 A max. current $I_{max}$ 63 A consumption < 0.02 W/phase start current 0.004 $I_N$
<b>Technical data</b>		approbations active energy EN 61036 class 1 reactive energy EN 61268 class 2 construction housing PA6.6 in conformity with UL 94 V-0 dimensions (mm) 108 x 90 x 72 weight 0.6 kg mounting DIN rail acc. to DIN DIN EN 50022 climatic conditions EN 61036 interior meter ambient temperature operation -20 °C to +55 °C storage -25 °C to +70 °C protection class 2 current terminals < 16 mm <sup>2</sup> control terminals < 2.5 mm <sup>2</sup> tariff start 230 V AC Tariff 2 is energized when terminals 13 and 15 are under load of 230 V AC.

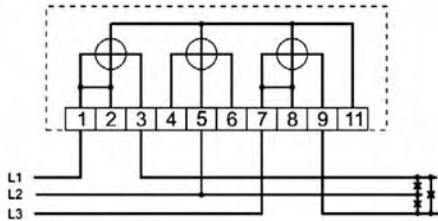


photo is similar to the original

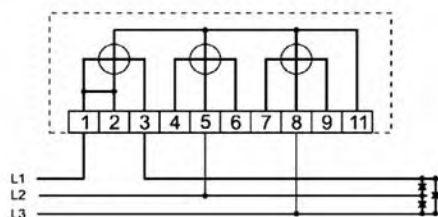
drawing



diagram



option EEH8116  
equally load phases



# EEH2116

## Three-phase energy meter

AC energy meter for dual tariff, suitable for clip-on to 35 mm DIN rail

### Type of energy meter EEH2116

<b>Mains</b>	3-wire	L-L (400 V)
	rated voltage $U_N$	230 V
	tolerance value	-20 %...+15 %
	consumption	< 3.0 W/phase
	frequency	50 Hz
	frequency range	45...65 Hz

### Output 1 S0-impulse output

(S0)	optocoupler	40 V / 27 mA max.
collector open	impulse duration	100 ms +/-50 %
	output impulse	1000 Imp/kWh
	connection terminal	40 / 41

### (option) communication

communication	RS485	EEH2316
	connection	multi-drop
	cable type	screened, wound pair
	max. cable length	1000 m
	connection	terminal screw
	isolation	3.7 kV rms for 1 min. between all meters and other units
	transmission system	asynchronous
	format type	MODBUS RTU
	transmission time	1200 to 19200 bits/s
	connection A and B	120 Ohm
	max. linked meters	32

### Counter 1 counter meter for active energy (kWh)

	electro-mechanical meter	
	number of digits	7 (6.1 digits)
	digit height	4 mm
	digit width	1.2 mm
	LED test	1000 Imp/kWh (red)
	LED operations	status (red)

### (option) 1 meter for reactive energy (kvarh)

	EEH2106
--	---------

### Current range 10 (63) A

	nominal current $I_N$	10 A
	max. current $I_{max}$	63 A
	consumption	< 0.02 W/phase
	start current	0.004 $I_N$

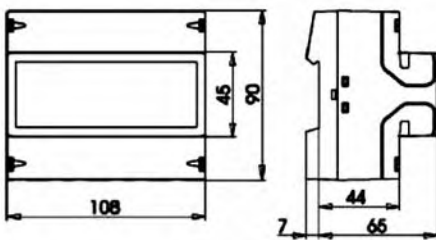
### Technical data

	approbations		
	active energy	EN 61036	class 1
	reactive energy	EN 61268	class 2
construction	housing	PA6.6 in conformity with UL 94 V-0	
	dimensions (mm)	108 x 90 x 72	
	weight	0.6 kg	
	mounting	DIN rail acc. to DIN EN 50022	
	climatic conditions	EN 61036	interior meter
ambient temperature	operation	-20 °C to +55 °C	
	storage	-25 °C to +70 °C	
	protection class	2	
	current terminals	< 16 mm <sup>2</sup>	
	control terminals	< 2.5 mm <sup>2</sup>	

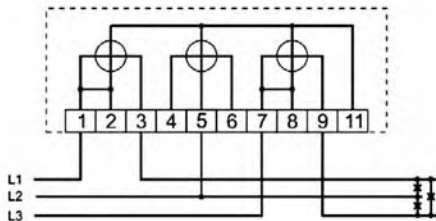


photo is similar to the original

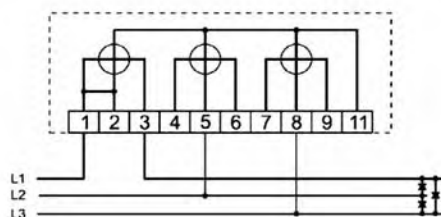
drawing



diagram



option EEH8226  
equally load phases



# EEH2126

## Three-phase energy meter

AC energy meter for dual tariff, suitable for clip-on to 35 mm DIN rail

**Type of energy meter** EEH2126

<b>Mains</b>	3-wire	L-L (400 V)
	rated voltage $U_N$	230 V
	tolerance value	-20 %...+15 %
	consumption	< 3.0 W/phase
	frequency	50 Hz
	frequency range	45...65 Hz

**Output** 1 S0-impulse output

(S0) collector open	optocoupler	40 V / 27 mA max.
	impulse duration	100 ms +/-50 %
	output impulse	1000 Imp/kWh
	connection terminal	40 / 41 / 42

(option) communication RS485

communication	RS485 connection	EEH2426 multi-drop
	cable type	screened, wound pair
	max. cable length	1000 m
	connection terminal	terminal screw
	isolation	3.7 kV rms for 1 min. between all meters and other units
	transmission system	asynchronous
	format type	MODBUS RTU
	transmission time	1200 to 19200 bits/s
	connection A and B	120 Ohm
	max. linked meters	32

**Counter** 2 counter meters for active energy HT-NT (kWh)

	2 electro-mechanical meters	
	number of digits	7 (6.1 digits)
	digit height	4 mm
	digit width	1.2 mm
	LED test	1000 Imp/kWh (red)
	LED operation	status (tariffs) (red)

(option)	2 meters for active/reactive energy (kWh/kvarh)	EEH2236
	2 meters for active energy (import/export) kWh	EEH2246

**Current range** 10 (63) A

	nominal current $I_N$	10 A
	max. current $I_{max}$	63 A
	consumption	< 0.02 W/current path
	start current	0.004 $I_N$

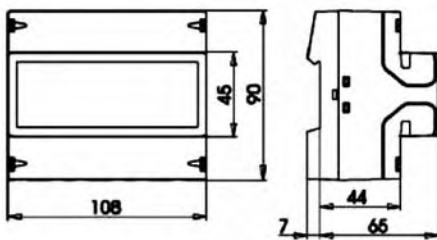
**Technical data**

construction	approbations	EN 61036	class 1
	active energy	EN 61268	class 2
	reactive energy		
construction	housing	PA6.6 in conformity with UL 94 V-0	
	dimensions (mm)	108 x 90 x 72	
	weight	0.6 kg	
ambient temperature	mounting	DIN rail acc. to DIN EN 50022	
	climatic conditions	EN 61036	interior meter
	operation	-20 °C to +55 °C	
ambient temperature	storage	-25 °C to +70 °C	
	protection class	2	
	current terminals	< 16 mm <sup>2</sup>	
ambient temperature	control terminals	< 2.5 mm <sup>2</sup>	
	tariff start	230 V AC	
		Tariff 2 is energized when terminals 13 and 15 are under load of 230 V AC.	

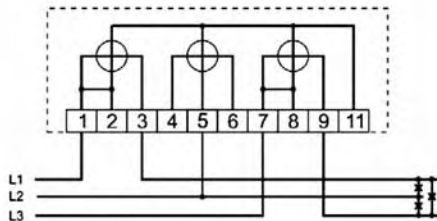


photo is similar to the original

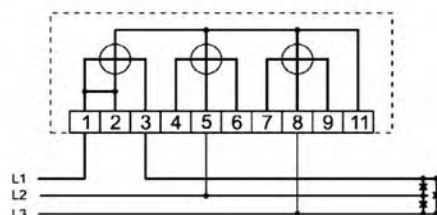
drawing



diagram



option EEH8276  
equally load phases



# EEH2176

## Three-phase energy meter

AC energy meter for dual tariff, suitable for clip-on to 35 mm DIN rail

**Type of energy meter** EEH2176

<b>Mains</b>	3-wire	L-L (400 V)
	rated voltage $U_N$	230 V
	tolerance value	-20 %...+15 %
	consumption	< 3.0 W/phase
	frequency	50 Hz
	frequency range	45...65 Hz

<b>Output</b>	1 S0-impulse output	
(S0)	optocoupler	40 V / 27 mA max.
collector open	impulse duration	100 ms +/-50 %
	output impulse	1000 Imp/kWh
	connection terminal	40 / 41 / 42

(option)	communication	RS485	EEH2476
	connection	multi-drop	
	cable type	screened, wound pair	
	max. cable length	1000 m	
	connection	terminal screw	
	isolation	3.7 kV rms for 1 min. between all meters and other units	
	transmission system	asynchronous	
	format type	MODBUS RTU	
	transmission time	1200 to 19200 bits/s	
	connection A and B	120 Ohm	
	max. linked meters	32	

<b>Counter</b>	LCD counter meter for active energy HT-NT (kWh)	
	number of digits	2 x 9 (8.1 digits)
	digit height	4.86 mm
	digit width	2.96 mm

(option)	2 meters for active/reactive energy (kWh/kvarh)	EEH2286
	2 meters for active energy (import/export) kWh	EEH2296

<b>Current range</b>	10 (63) A	
	nominal current $I_N$	10 A
	max. current $I_{max}$	63 A
	consumption	< 0.02 W/current path
	start current	0.004 $I_N$

### Technical data

	approbations	active energy	EN 61036	class 1
		reactive energy	EN 61268	class 2
construction	housing	PA6.6 in conformity with UL 94 V-0		
	dimensions (mm)	108 x 90 x 72		
	weight	0.6 kg		
	mounting	DIN rail acc. to DIN EN 50022		
	climatic conditions	EN 61036	interior meter	
ambient temperature	operation	-20 °C to +55 °C		
	storage	-25 °C to +70 °C		
	protection class	2		
	current terminals	< 16 mm <sup>2</sup>		
	control terminals	< 2.5 mm <sup>2</sup>		
	tariff start	230 V AC		
	Tariff 2 is energized when terminals 13 and 15 are under load of 230 V AC.			

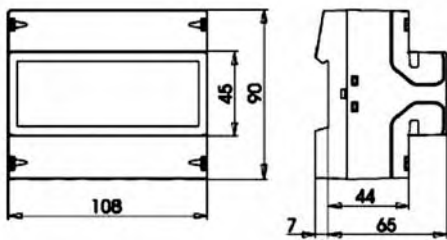


# EEH1115

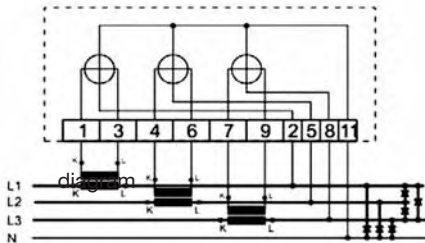
## Three-phase energy transformer meter

AC energy transformer meter, suitable for clip-on to 35 mm DIN rail

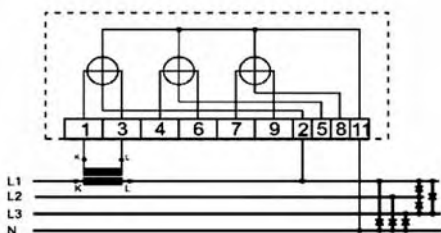
drawing



diagram



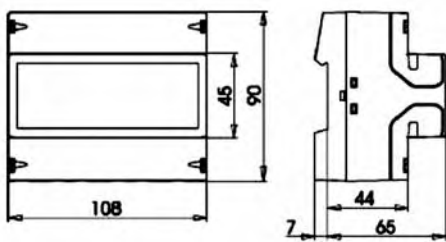
option EEH5115xxxx  
equally load phases



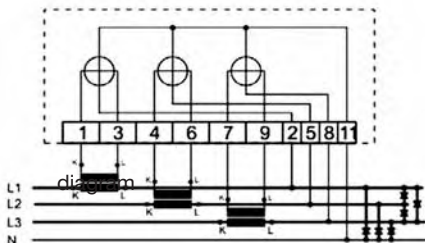
<b>Type of energy meter</b>		EEH1115xxxx
		xxxx declaring the primary current is absolutely necessary
<b>Mains</b>		4-wire L-N (230 V)
		rated voltage $U_N$ 230 V
		tolerance value -20 %... +15 %
		consumption < 3.0 VA
		frequency 50 Hz
		frequency range 45...65 Hz
<b>Output</b>		1 S0-impulse output
		optocoupler 40 V / 27 mA max.
		impulse duration 100 ms +/-50 %
(S0) collector open	output impulse	1000 Imp/kWh
	connection terminal	40 / 41
<b>(option) communication</b>		RS485 EEH1315xxxx
		connection multi-drop
		cable type screened, wound pair
		max. cable length 1000 m
		connection terminal screw
		isolation 3.7 kV rms for 1 min. between all meters and other units
		transmission system asynchronous
		format type MODBUS RTU
		transmission time 1200 to 19200 bits/s
		connection A and B 120 Ohm
		max. linked meters 32
<b>Counter</b>		1 counter meter for active energy
		electro-mechanical meter
		number of digits 7 (6.1 digits)
		digit height 4 mm
		digit width 1.2 mm
		LED test 1000 Imp/kWh (red)
		LED operation status (red)
<b>(option)</b>	reactive energy	EEH1105xxxx
<b>Current range</b>		5 A
		nominal current $I_N$ 5 A
		max. current $I_{max}$ 6 A
		consumption < 0.02 W/current path
		start current 0.002 $I_N$
<b>(option)</b>	nominal current $I_N$	1 A EEH1111xxxx
<b>Primary current</b>		0.5 A to 2000 A
		If not stated otherwise, the standard version 5 A or 1 A will be supplied
<b>Technical data</b>		
		approbations
		active energy EN 61036 class 1
		reactive energy EN 61268 class 2
construction	housing	PA6.6 in conformity with UL 94 V-0
	dimensions (mm)	108 x 90 x 72
	weight	0.6 kg
ambient temperature	mounting	DIN rail acc. to DIN EN 50022
	climatic conditions	EN 61036 interior meter
operation	operation	-20 °C to +55 °C
	storage	-25 °C to +70 °C
	protection class	2
	current terminals	< 10 mm <sup>2</sup>
	control terminals	< 2.5 mm <sup>2</sup>



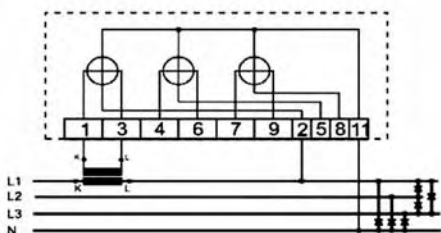
drawing



diagram



option EEH5225  
equally load phases



# EEH1125

## Three-phase energy transformer meter

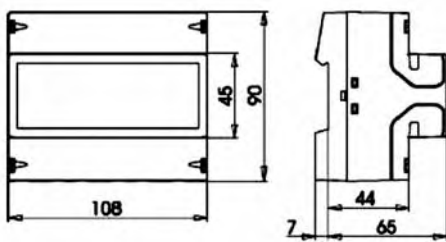
AC energy transformer meter for dual tariff, suitable for clip-on to 35 mm DIN rail

<b>Type of energy meter</b>	EEH1125xxxx	
	xxxx declaring the primary current is absolutely necessary	
<b>Mains</b>	4-wire	L-N (230 V)
	rated voltage $U_N$	230 V
	tolerance value	-20 %...+15 %
	consumption	< 3.0 W/phase
	frequency	50 Hz
	frequency range	45...65 Hz
<b>Output</b>	1 S0-impulse output	
	optocoupler	40 V / 27 mA max.
(S0)	impulse duration	100 ms +/-50 %
collector open	output impulse	1000 Imp/kWh
	connection terminal	40 / 41 / 42
(option)		
communication	RS485	EEH1425xxxx
	connection	multi-drop
	cable type	screened, wound pair
	max. cable length	1000 m
	connection	terminal screw
	isolation	3.7 kV rms for 1 min. between all meters and other units
	transmission system	asynchronous
	format type	MODBUS RTU
	transmission time	1200 to 19200 bits/s
	connection A and B	120 Ohm
	max. linked meters	32
<b>Counter</b>	2 counter meters for active energy HT-NT (kWh)	
	2 electro-mechanical meters	
	number of digits	7 (6.1 digits)
	digit height	4 mm
	digit width	1.2 mm
	LED test	1000 Imp/kWh (red)
	LED operation	status (tariffs) (red)
(option)		
	2 meters for active/reactive energy (kWh/kvarh)	EEH1235xxxx
	2 meters for active energy (import/export) (kWh)	EEH1245xxxx
<b>Current range</b>	5 A	
	nominal current $I_N$	5 A
	max. current $I_{max}$	6 A
	consumption	< 0.02 W/current path
	start current	0.002 $I_N$
(option)		
	nominal current $I_N$	1 A EEH1221xxxx
<b>Primary current</b>	0.5 A to 2000 A	
	If not stated otherwise, the standard version 5 A or 1 A will be supplied	
<b>Technical data</b>		
	approbations	
	active energy	EN 61036 class 1
	reactive energy	EN 61268 class 2
construction	housing	PA6.6 in conformity with UL 94 V-0
	dimensions (mm)	108 x 90 x 72
	weight	0.6 kg
	mounting	DIN rail acc. to DIN EN 50022
	climatic conditions	EN 61036 interior meter
ambient temperature	operation	-20 °C to +55 °C
	storage	-25 °C to +70 °C
	protection class	2
	current terminals	< 10 mm <sup>2</sup>
	control terminals	< 2.5 mm <sup>2</sup>
	tariff start	230 V AC
	Tariff 2 is energized when terminals 13 and 15 are under load of 230 V AC.	

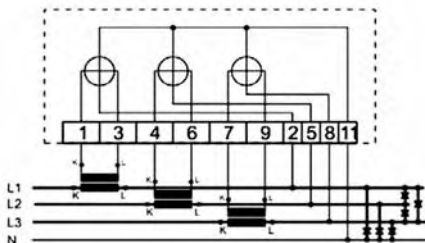


photo is similar to the original

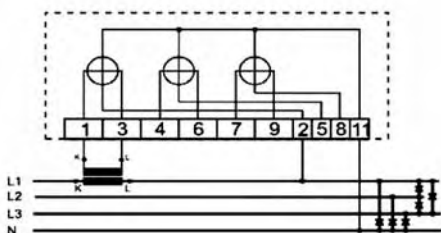
drawing



diagram



option EEH5275xxxx  
equally load phases



# EEH1175

## Three-phase energy transformer meter

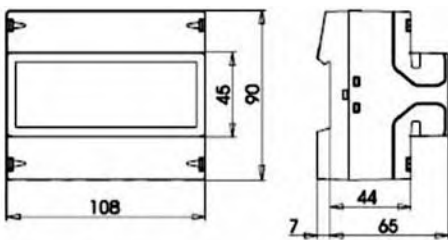
AC energy transformer meter for dual tariff, suitable for clip-on to 35 mm DIN rail

<b>Type of energy meter</b>	EEH1175xxxx	
	xxxx declaring the primary current is absolutely necessary	
<b>Mains</b>	4-wire	L-N (230 V)
	rated voltage $U_N$	230 V
	tolerance value	-20 %...+15 %
	consumption	< 3.0 W
	frequency	50 Hz
	frequency range	45...65 Hz
<b>Output</b>	1 S0-impulse output	
	optocoupler	40 V / 27 mA max.
(S0)	impulse duration	100 ms +/-50 %
collector open	output impulse	1000 Imp/kWh
	connection terminal	40 / 41
(option)	communication	RS485
	connection	EEH1475xxxx
	cable type	multi-drop
	max. cable length	screened, wound pair
	connection	1000 m
	isolation	terminal screw
		3.7 kV rms for 1 min. between all meters and other units
	transmission system	asynchronous
	format type	MODBUS RTU
	transmission time	1200 to 19200 bits/s
	connection A and B	120 Ohm
	max. linked meters	32
<b>Counter</b>	LCD counter meter for active energy HT-NT (kWh)	
	number of digits	2 x 9 (8.1-digits)
	digit height	4.86 mm
	digit width	2.96 mm
(option)	2 meters for active/reactive energy (kWh/kvarh)	EEH1285xxxx
	2 meters for active energy (import/export) (kWh)	EEH1295xxxx
<b>Current range</b>	5 A	
	nominal current $I_N$	5 A
	max. current $I_{max}$	6 A
	consumption	< 0.02 W/current path
	start current	0.002 $I_N$
(option)	nominal current $I_N$	1 A EEH1271xxxx
<b>Primary current</b>	0.5 A to 2000 A	
	If not stated otherwise, the standard version 5 A or 1 A will be supplied	
<b>Technical data</b>		
	approbations	
	active energy	EN 61036 class 1
	reactive energy	EN 61268 class 2
construction	housing	PA6.6 in conformity with UL 94 V-0
	dimensions (mm)	108 x 90 x 72
	weight	0.6 kg
	mounting	DIN rail acc. to DIN EN 50022
	climatic conditions	EN 61036 interior meter
ambient temperature	operation	-20 °C to +55 °C
	storage	-25 °C to +70 °C
	protection class	2
	current terminals	< 10 mm <sup>2</sup>
	control terminals	< 2.5 mm <sup>2</sup>
	tariff start	230 V AC
	Tariff 2 is energized when terminals 13 and 15 are under load of 230 V AC.	

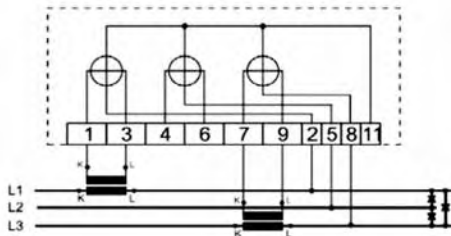


photo is similar to the original

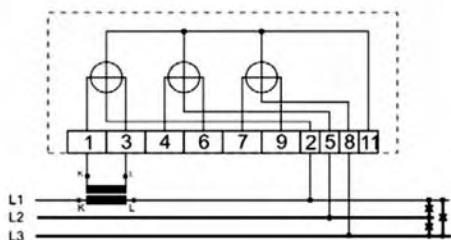
drawing



diagram



option EEH8115xxxx  
equally load phases



# EEH2115

## Three-phase energy transformer meter

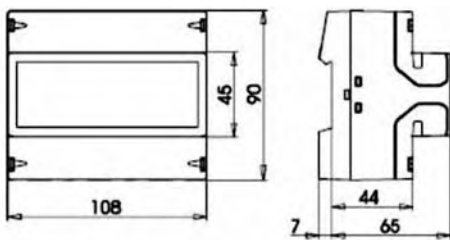
AC energy transformer meter for clip-on to 35 mm DIN rail

<b>Type of energy meter</b>	EEH2115xxxx	
	xxxx declaring the primary current is absolutely necessary	
<b>Mains</b>	3-wire	L-L (400 V)
	rated voltage $U_N$	230 V
	tolerance value	-20 %...+15 %
	consumption	< 3.0 W/phase
	frequency	50 Hz
	frequency range	45...65 Hz
<b>Output</b>	1 S0-impulse output	
	optocoupler	40 V / 27 mA max.
(S0)	impulse duration	100 ms +/-50 %
collector open	output impulse	1000 Imp/kWh
	connection terminal	40 / 41
(option)		
communication	RS485	EEH2315xxxx
	connection	multi-drop
	cable type	screened, wound pair
	max. cable length	1000 m
	connection	terminal screw
	isolation	3.7 kV rms for 1 min. between all meters and other units
	transmission system	asynchronous
	format type	MODBUS RTU
	transmission time	1200 to 19200 bits/s
	connection A and B	120 Ohm
	max. linked meters	32
<b>Counter</b>	1 counter meter for active energy (kWh)	
	electro-mechanical meter	
	number of digits	7 (6.1 digits)
	digit height	4 mm
	digit width	1.2 mm
	LED test	1000 Imp/kWh (red)
	LED operation	status (red)
(option)	reactive energy (kvarh)	EEH2105xxxx
<b>Current range</b>	5 A	
	nominal current $I_N$	5 A
	max. current $I_{max}$	6 A
	consumption	< 0.02 W/current path
	start current	0.002 $I_N$
(option)	nominal current $I_N$	1 A EEH2111xxxx
<b>Primary current</b>	0.5 A to 2000 A	
	If not stated otherwise, the standard version 5 A or 1 A will be supplied	
<b>Technical data</b>		
	approbations	
	active energy	EN 61036 class 1
	reactive energy	EN 61268 class 2
construction	housing	PA6.6 in conformity with UL 94 V-0
	dimensions (mm)	108 x 90 x 72
	weight	0.6 kg
	mounting	DIN rail acc. to DIN EN 50022
	climatic conditions	EN 61036 interior meter
ambient temperature	operation	-20 °C to +55 °C
	storage	-25 °C to +70 °C
	protection class	2
	current terminals	< 10 mm <sup>2</sup>
	control terminals	< 2.5 mm <sup>2</sup>

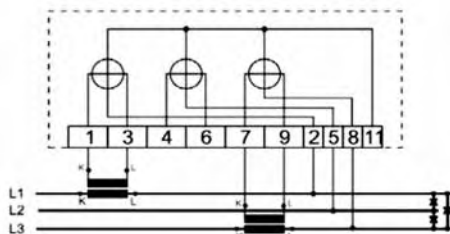


photo is similar to the original

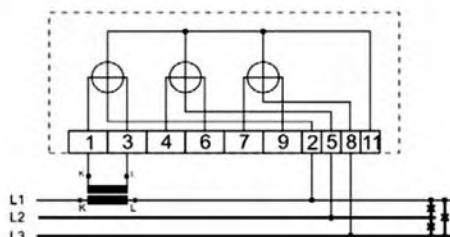
drawing



diagram



option EEH8225xxxx  
equally load phases



# EEH2125

## Three-phase energy transformer meter

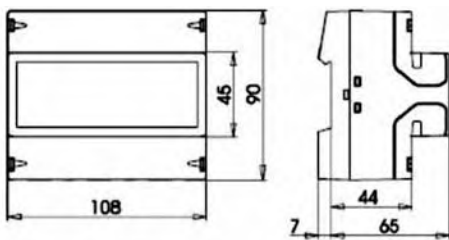
AC energy transformer meter for dual tariff for clip-on to 35 mm DIN rail

<b>Type of energy meter</b>	EEH2125xxxx	
	xxxx declaring the primary current is absolutely necessary	
<b>Mains</b>	3-wire	L-L (400 V)
	rated voltage $U_N$	230 V
	tolerance value	-20 %...+15 %
	consumption	< 3.0 W/phase
	frequency	50 Hz
	frequency range	45...65 Hz
<b>Output</b>	1 S0-impulse output	
	optocoupler	40 V / 27 mA max.
(S0)	impulse duration	100 ms +/-50 %
collector open	output impulse	1000 Imp/kWh
	connection terminal	40 / 41 / 42
(option)		
communication	RS485	EEH2425xxxx
	connection	multi-drop
	cable type	screened, wound pair
	max. cable length	1000 m
	connection	terminal screw
	isolation	3.7 kV rms for 1 min. between all meters and other units
	transmission system	asynchronous
	format type	MODBUS RTU
	transmission time	1200 to 19200 bits/s
	connection A and B	120 Ohm
	max. linked meters	32
<b>Counter</b>	2 counter meters for active energy HT-NT (kWh)	
	2 electro-mechanical meters	
	number of digits	7 (6.1 digits)
	digit height	4 mm
	digit width	1.2 mm
	LED test	1000 Imp/kWh (red)
	LED operation	status (tariffs) (red)
(option)		
2 meters for active/reactive energy (kWh/kvarh)	EEH2235xxxx	
2 meters for active energy (kWh)	EEH2245xxxx	
<b>Current range</b>	5 A	
	nominal current $I_N$	5 A
	max. current $I_{max}$	6 A
	consumption	< 0.02 W/current path
	start current	0.002 $I_N$
(option)		
nominal current $I_N$	1 A	EEH2221xxxx
<b>Primary current</b>	0.5 A to 2000 A	
	If not stated otherwise, the standard version 5 A or 1 A will be supplied.	
<b>Technical data</b>		
	approbations	
	active energy	EN 61036 class 1
	reactive energy	EN 61268 class 2
construction	housing	PA6.6 in conformity with UL 94 V-0
	dimensions (mm)	108 x 90 x 72
	weight	0.6 kg
	mounting	DIN rail acc. to DIN EN 50022
	climatic conditions	EN 61036 interior meter
	operating temperature	-20 °C to +55 °C
	storage temperature	-25 °C to +70 °C
	protection class	2
	current terminals	< 10 mm <sup>2</sup>
	control terminals	< 2.5 mm <sup>2</sup>
	tariff start	230 V AC
	Tariff 2 is energized when terminals 13 and 15 are under load of 230 V AC.	

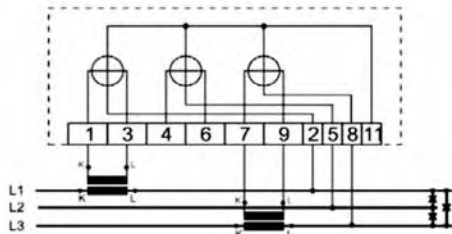


photo is similar to the original

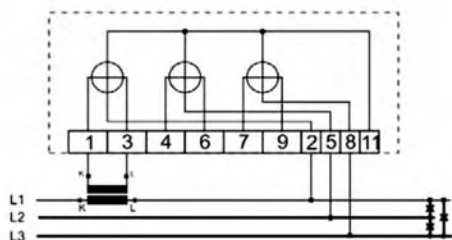
drawing



diagram



option EEH8275xxxx  
equally load phases



# EEH2175

## Three-phase energy transformer meter

AC energy transformer meter for dual tariff for clip-on to 35 mm DIN rail

<b>Type of energy meter</b>	EEH2175xxxx	
<b>Mains</b>	xxxx declaring the primary current is absolutely necessary	
	3-wire	L-L (400 V)
	rated voltage $U_N$	230 V
	tolerance value	-20 %...+15 %
	consumption	< 3.0 W
	frequency	50 Hz
	frequency range	45...65 Hz
	<b>Output</b>	1 S0-impulse output
	optocoupler	40 V / 27 mA max.
(S0)	impulse duration	100 ms +/-50 %
collector open	output impulse	1000 Imp/kWh
	connection terminal	40 / 41
(option)	communication	RS485
	connection	EEH2475xxxx
	cable type	multi-drop
	max. cable length	screened, wound pair
	connection	1000 m
	isolation	terminal screw
		3.7 kV rms for 1 min. between all meters and other units
	transmission system	asynchronous
	format type	MODBUS RTU
	transmission time	1200 to 19200 bits/s
	connection A and B	120 Ohm
	max. linked meters	32

<b>Counter</b>	LCD counter meter for active energy HT-NT (kWh)	
	number of digits	2 x 9 (8.1 digits)
	digit height	4.86 mm
	digit width	2.96 mm

(option)	2 meters for active/reactive energy (kWh/kvarh)	EEH2285xxxx
	2 meters for active energy (import/export) (kWh)	EEH2295xxxx

<b>Current range</b>	5 A	
	nominal current $I_N$	5 A
	max. current $I_{max}$	6 A
	consumption	< 0.02 W/current path
	start current	0.002 $I_N$
(option)	nominal current $I_N$	1 A EEH2271xxxx

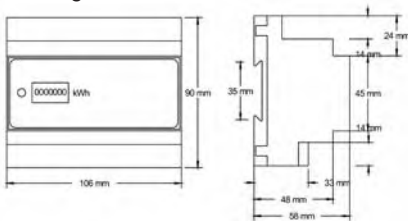
<b>Primary current</b>	0.5 A to 2000 A	
	If not stated otherwise, the standard version 5 A or 1 A will be supplied	

<b>Technical data</b>		
approbations	active energy	EN 61036 class 1
	reactive energy	EN 61268 class 2
construction	housing	PA6.6 in conformity with UL 94 V-0
	dimensions (mm)	108 x 90 x 72
	weight	0.6 kg
	mounting	DIN rail acc. to DIN EN 50022
	climatic conditions	EN 61036 interior meter
ambient temperature	operation	-20 °C to +55 °C
	storage	-25 °C to +70 °C
	protection class	2
	current terminals	< 10 mm <sup>2</sup>
	control terminals	< 2.5 mm <sup>2</sup>
	tariff start	230 V AC
	Tariff 2 is energized when terminals 13 and 15 are under load of 230 V AC.	

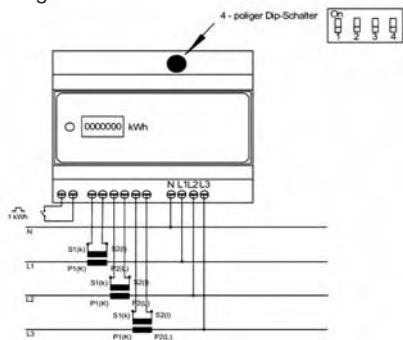


photo is similar to the original

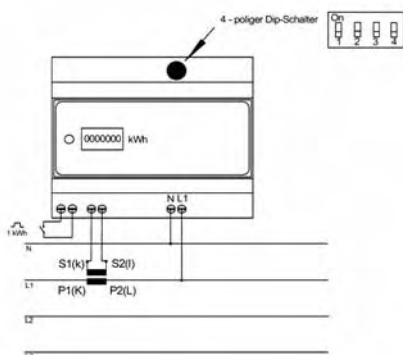
drawing



diagram



option EWS5915xxxx  
equally load phases



# EWS1915

## Three-phase energy transformer meter

AC energy transformer meter for clip-on to 35 mm DIN rail

**Type of energy meter** EWS1915xxxx

xxxx declaring the primary current is absolutely necessary

**Mains** 4-wire L-N (230 V)

rated voltage  $U_N$  57 V, 100 V, 230 V, 400 V  
 tolerance value -20 %...+20 %  
 consumption < 3.0 W/phase  
 frequency 50 Hz  
 frequency range 45...65 Hz

**Output** 1 relay impulse output

relay 250 V, 6 A, 50 Hz  
 impulse duration 100 ms  
 max. load 1500 W  
 output impulse 1 Imp/kWh  
 max. impulse 4000/h

(option) EWS1115xxxx

optocoupler 40 V / 27 mA max.  
 (S0) impulse duration 100 ms +/-50 %  
 collector open output impulse 1 Imp/Wh (30...250 A)  
 output impulse 10 Imp/Wh (300...2000 A)  
 impedance 100 Ohm

**Counter** 1 counter meter for active energy (kWh)

electro-mechanical meter  
 number of digits 7 (7.0 digits)  
 digit height 4 mm  
 digit width 1.2 mm  
 LED test 8 Imp/kWh

**Current range** xxxx/5 A (dip-switch setting)

nominal current  $I_N$  5 A  
 max. current  $I_{max}$  6 A  
 consumption < 0.1 W/current path  
 start current 0.002  $I_N$

(option) nominal current  $I_N$  xxxx/1 A EWS1911xxxx

**Primary current** 0.5 A to 2000 A

If not stated otherwise, the standard version 30/5 A or 30/1 A will be supplied

**Technical data**

approbations active energy EN 61036 class 1  
 construction polycarbonate housing acc. to UL 94 V-0  
 colour RAL 7035  
 dimensions (mm) 106 x 90 x 58  
 weight 0.3 kg  
 mounting DIN rail acc. to DIN EN 50022  
 ambient temperature operation -10 °C to +60 °C  
 storage -40 °C to +70 °C  
 protection class 2

setting of the 4-pole dip switch

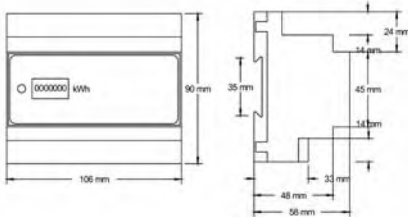
In	1	2	3	4	In	1	2	3	4	In	1	2	3	4	In	1	2	3	4	In	1	2	3	4	In	1	2	3	4
30	○	○	○	○	50	●	○	○	○	100	○	○	○	○	250	●	●	○	○	500	○	○	○	○	1000	○	○	○	○
On	●				60	○	○	○	○	150	○	○	○	○	300	○	○	○	○	600	○	○	○	○	1500	○	○	○	○
Off	○				80	○	○	○	○	200	○	○	○	○	400	○	○	○	○	800	○	○	○	○	2000	○	○	○	○

deviating primary currents are programmed at works according to the details of the order.

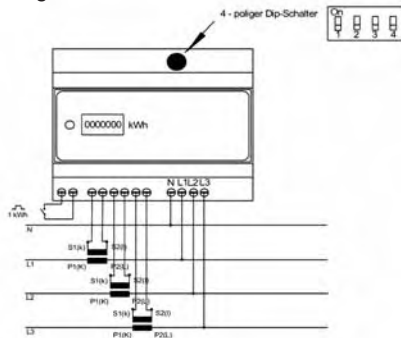


photo is similar to the original

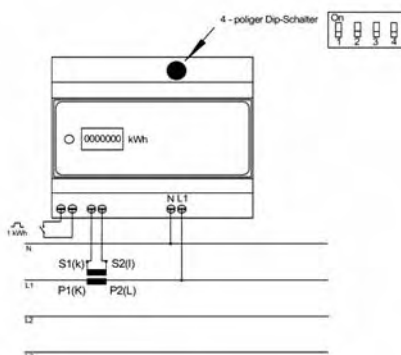
drawing



diagram



option EWS5945xxxx  
equally load phases



# EWS1945

## Three-phase energy transformer meter

AC energy transformer meter for clip-on to 35 mm DIN rail

<b>Type of energy meter</b>	EWS1945xxxx xxxx declaring the primary current is absolutely necessary	
<b>Mains</b>	4-wire rated voltage $U_N$ tolerance value consumption frequency frequency range	L-N (230 V) 57 V, 100 V, 230 V, 400 V -20 %...+20 % < 3.0 W/phase 50 Hz 45...65 Hz
<b>Output</b>	1 relay impulse output	relay 250 V, 6 A, 50 Hz impulse duration 100 ms max. load 1500 W output impulse 1 Imp/kWh max. impulse 4000/h
(option) (S0) collector open	EWS1145xxxx optocoupler impulse duration output impulse output impulse impedance	40 V / 27 mA max. 100 ms +/- 50 % 1 Imp/Wh (30...250 A) 10 Imp/Wh (300...2000 A) 100 Ohm
<b>Counter</b>	2 counter meters for active energy (import/export) (kWh) 2 electro-mechanical meters	number of digits 7 (7.0 digits) digit height 4 mm digit width 1.2 mm LED test 8 Imp/kWh
(option)	2 meters for active/reactive energy (kWh/kvarh)	EWS1935
<b>Current range</b>	xxxx/5 A (dip-switch setting)	nominal current $I_N$ 5 A max. current $I_{max}$ 6 A consumption < 0.1 W/current path start current 0.002 $I_N$
(option)	nominal current $I_N$ xxx/1 A	EWS1941xxxx
<b>Primary current</b>	0.5 A to 2000 A If not stated otherwise, the standard version 30/5 A or 30/1 A will be supplied	
<b>Technical data</b>	approbations active energy construction colour dimensions (mm) weight mounting ambient temperature operation storage protection class	EN 61036 class 1 acc. to UL 94 V-0 RAL 7035 106 x 90 x 58 0.3 kg DIN rail acc. to DIN EN 50022 -10 °C to +60 °C -40 °C to +70 °C 2

setting of the 4-pole dip switch

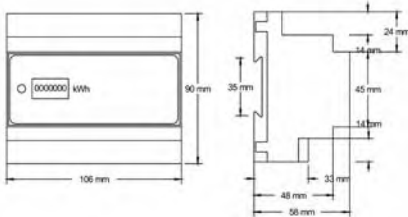
In	1	2	3	4	In	1	2	3	4	In	1	2	3	4	In	1	2	3	4	In	1	2	3	4	In	1	2	3	4
30	○	○	○	○	50	●	○	○	○	100	○	○	○	○	250	●	○	○	○	500	○	○	○	○	1000	●	○	○	○
On	●				60	○	○	○	○	150	○	○	○	○	300	○	○	○	○	600	○	○	○	○	1500	○	○	○	○
Off	○				80	○	○	○	○	200	○	○	○	○	400	○	○	○	○	800	○	○	○	○	2000	○	○	○	○

deviating primary currents are programmed at works according to the details of the order.

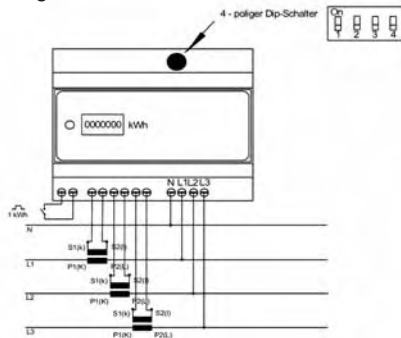


photo is similar to the original

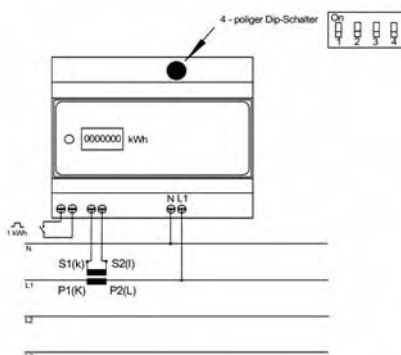
drawing



diagram



option EWS5995xxxx  
equally load phases



# EWS1995

## Three-phase energy transformer meter

AC energy transformer meter for clip-on to 35 mm DIN rail

<b>Type of energy meter</b>	EWS1995xxxx xxxx declaring the primary current is absolutely necessary	
<b>Mains</b>	4-wire rated voltage $U_N$ tolerance value consumption frequency frequency range	L-N (230 V) 57 V, 100 V, 230 V, 400 V -20 %...+20 % < 3.0 W/phase 50 Hz 45...65 Hz
<b>Output</b>	1 relay impulse output relay impulse duration max. load output impulse max. impulse	250 V, 6 A, 50 Hz 100 ms 1500 W 1 Imp/kWh 4000/h
(option) (S0) collector open	EWS1195xxxx optocoupler impulse duration output impulse output impulse impedance	40 V / 27 mA max. 100 ms +/- 50 % 1 Imp/Wh (30...250 A) 10 Imp/Wh (300...2000 A) 100 Ohm
<b>Counter</b>	LCD counter meter for active energy import/export (kWh) LCD counter meter number of digits digit height digit width	
(option) LCD counter meters for active/reactive energy (kWh/kvarh)	EEH1985	
<b>Current range</b>	xxxx/5 A (dip-switch setting) nominal current $I_N$ max. current $I_{max}$ consumption start current	
(option)	nominal current $I_N$ xxxx/1 A	EWS191xxxx
<b>Primary current</b>	0.5 A to 2000 A If not stated otherwise, the standard version 30/5 A or 30/1 A will be supplied	
<b>Technical data</b>	approbations active energy construction polycarbonate housing colour dimensions (mm) weight mounting ambient temperature operation storage protection class	
	EN 61036 class 1 acc. to UL 94 V-0 RAL 7035 106 x 90 x 58 0.3 kg DIN rail acc. to DIN EN 50022 -10 °C to +60 °C -40 °C to +70 °C 2	

setting of the 4-pole dip switch

In	1	2	3	4	In	1	2	3	4	In	1	2	3	4	In	1	2	3	4	In	1	2	3	4	In	1	2	3	4
30	○	○	○	○	50	●	○	○	○	100	○	○	○	○	250	●	●	○	○	500	○	○	○	○	1000	○	○	○	○
On	●				60	○	○	○	○	150	○	○	○	○	300	○	○	○	○	600	○	○	○	○	1500	○	○	○	○
Off	○				80	○	○	○	○	200	○	○	○	○	400	○	○	○	○	800	○	○	○	○	2000	○	○	○	○

deviating primary currents are programmed at works according to the details of the order.

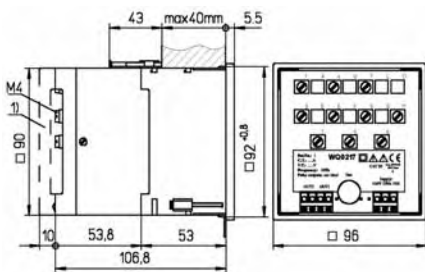


# EWQ1915

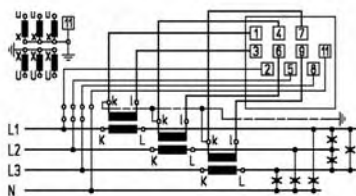
## Three-phase energy transformer meter

AC energy transformer meter for panel board installation 96 x 96 mm

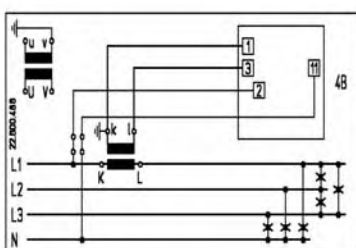
drawing



diagram



option EWQ5915xxxx  
equally load phases



<b>Type of energy meter</b>	EWQ1915xxxx
	xxxx declaring the primary current is absolutely necessary

<b>Mains</b>	4-wire	L-N (230 V)
	rated voltage $U_N$	57 V, 100 V, 230 V, 400 V
	tolerance value	-20 %...+20 %
	consumption	< 3.0 W/phase
	frequency	50 Hz
	frequency range	45...65 Hz

<b>Output</b>	1 relay impulse output	
	relay	250 V, 6 A, 50 Hz
	impulse duration	100 ms
	max. load	1500 W
	output impulse	1 Imp/kWh
	max. impulse	4000/h

<b>Counter</b>	1 counter meter for active energy (kWh)	
	electro-mechanical meter	
	number of digits	7 (7.0 digits)
	digit height	4 mm
	digit width	1.2 mm

<b>Current range</b>	xxxx/5 A	
	nominal current $I_N$	5 A
	max. current $I_{max}$	6 A
	consumption	< 0.1 W/current path
	start current	0.002 $I_N$

(option)	nominal current $I_N$	xxxx/1 A	EWQ1911xxxx
----------	-----------------------	----------	-------------

<b>Primary current</b>	0.5 A to 2000 A
	If not stated otherwise, the standard version 30/5 A or 30/1 A will be supplied

<b>Technical data</b>	approbations		
	active energy	EN 61036	class 1
construction	polycarbonate housing	acc. to UL 94 V-0	
	dimensions (mm)	96 x 96 x 106.8	
	weight	0.6 kg	
ambient temperature	mounting	front panel	
	operation	-10 °C to +60 °C	
	storage	-40 °C to +70 °C	
	protection class	2	

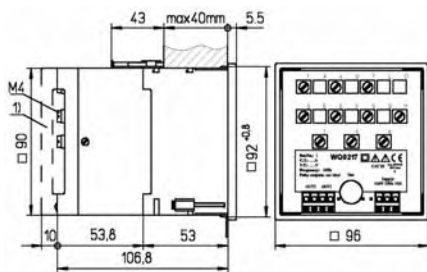


# EWQ1945

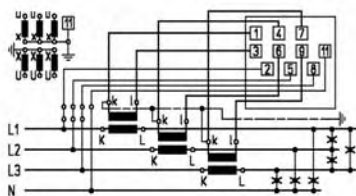
## Three-phase energy transformer meter

AC energy transformer meter for panel board installation 96 x 96 mm

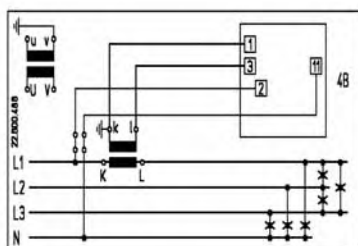
drawing



diagram



option EWQ5945xxxx  
equally load phases



**Type of energy meter** EWQ1945xxxx  
xxxx declaring the primary current is absolutely necessary

**Mains** 4-wire L-N (230 V)  
rated voltage  $U_N$  57 V, 100 V, 230 V, 400 V  
tolerance value -20 %...+20 %  
consumption < 3.0 W/phase  
frequency 50 Hz  
frequency range 45...65 Hz

**Output** 1 relay impulse output  
relay 250 V, 6 A, 50 Hz  
impulse duration 100 ms  
max. load 1500 W  
output impulse 1 Imp/kWh  
max. impulse 4000/h

**Counter** 2 counter meters for active energy import/export (kWh)  
electro-mechanical meter  
number of digits 7 (7.0 digits)  
digit height 4 mm  
digit width 1.2 mm

(option)  
2 meters for active/reactive energy (kWh/kvarh) EWQ1935

**Current range** xxxxx/5 A  
nominal current  $I_N$  5 A  
max. current  $I_{max}$  6 A  
consumption < 0.1 W/current path  
start current 0.002  $I_N$

(option) nominal current  $I_N$  xxxxx/1 A EWQ1941xxxx

**Primary current** 0.5 A to 2000 A  
If not stated otherwise, the standard version 5 A or 1 A will be supplied

**Technical data**  
approbations active energy EN 61036 class 1  
construction polycarbonate housing acc. to UL 94 V-0  
dimensions (mm) 96 x 96 x 106.8  
weight 0.6 kg  
mounting front panel  
ambient temperature operation -10 °C to +60 °C  
storage -40 °C to +70 °C  
protection class 2



# EWQ1995

## Three-phase energy transformer meter

AC energy transformer meter for panel board installation 96 x 96 mm

**Type of energy meter** EWQ1995xxxx  
xxxx declaring the primary current is absolutely necessary

**Mains** 4-wire L-N (230 V)  
rated voltage  $U_N$  57 V, 100 V, 230 V, 400 V  
tolerance value -20 %...+20 %  
consumption < 3.0 W/phase  
frequency 50 Hz  
frequency range 45...65 Hz

**Output** 1 relay impulse output  
relay 250 V, 6A, 50Hz  
impulse duration 100 ms  
max. load 1500 W  
output impulse 1 Imp/kWh  
max. impulse 4000/h

**Counter** LCD counter meter for active energy import/export (kWh)  
LCD counter  
number of digits 2x9 (9.0 digits)  
digit height 4.86 mm  
digit width 2.96 mm

(option)  
LCD counter for active/reactive energy (kWh/kvarh) EWQ1985

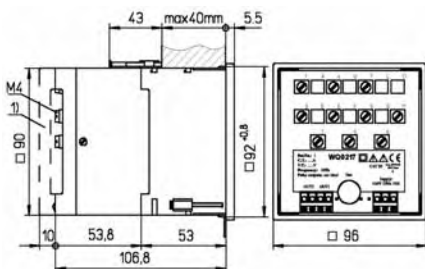
**Current range** xxxx/5 A  
nominal current  $I_N$  5 A  
max. current  $I_{max}$  6 A  
consumption < 0.1 W/current path  
start current 0.002  $I_N$

(option) nominal current  $I_N$  xxxx/1 A EWQ1991xxxx

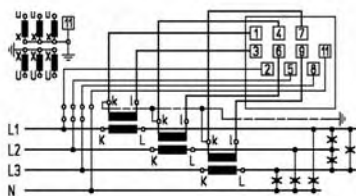
**Primary current** 0.5 A to 2000 A  
If not stated otherwise, the standard version 5 A or 1 A will be supplied

**Technical data**  
approbations active energy EN 61036 class 1  
construction polycarbonate housing acc. to UL 94 V-0  
dimensions (mm) 96 x 96 x 106.8  
weight 0.6 kg  
mounting front panel  
ambient temperature operation -10 °C to +60 °C  
storage -40 °C to +70 °C  
protection class 2

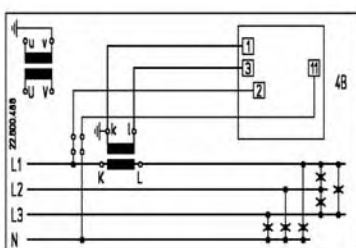
drawing



diagram



option EWQ5995xxxx  
equally load phases





## Electro-mechanical energy meters for industrial applications

### Single-phase energy meter, direct measuring

EMZ60110040	2-wire	220 V	kWh	10 (40) A
EMZ60110060	2-wire	220 V	kWh	10 (60) A

### Three-phase energy meter, direct measuring

EMZ10110040	4-wire	3x220/380 V		kWh	10 (40) A
EMZ10210040	4-wire	3x220/380 V	2 tariffs, HT-NT	kWh	10 (40) A
EMZ10115060	4-wire	3x220/380 V		kWh	15 (60) A
EMZ10215060	4-wire	3x220/380 V	2 tariffs, HT-NT	kWh	15 (60) A
EMZ10110060	4-wire	3x220/380 V		kWh	10 (60) A
EMZ10210060	4-wire	3x220/380 V	2 tariffs, HT-NT	kWh	10 (60) A
EMZ10120100	4-wire	3x220/380 V		kWh	20 (100) A
EMZ10125100	4-wire	3x220/380 V		kWh	25 (100) A

### Three-phase energy transformer meter

EMZ1015	4-wire	3x220/380 V		kWh	5 A
EMZ1025	4-wire	3x220/380 V	2 tariffs, HT-NT	kWh	5 A





## Electronic energy meter for tariff applications

### Single phase energy meter, direct measuring, clip-on to 35 mm DIN rail

					page
EAA7112	2-wire	1 S0-impulse output		kWh	5 (32) A . . . . .322
EMU7114	2-wire	1 S0-impulse output		kWh	5 (63) A . . . . .323
EMU7124	2-wire	1 S0-impulse output	2 tariffs	kWh	5 (63) A . . . . .324

### Three-phase energy meter, direct measuring, clip-on to 35 mm DIN rail

EEH4114	4-wire	1 S0-impulse output		kWh / kvarh	10 (63) A . . . . .325
EEH4124	4-wire	1 S0-impulse output	2 tariffs	+/- kWh / kvarh	10 (63) A . . . . .326
EEH4174	4-wire	1 S0-impulse output	LCD, 2 tariffs	+/- kWh / kvarh	10 (63) A . . . . .327
EEH3116	3-wire	1 S0-impulse output		kWh / kvarh	10 (63) A . . . . .328
EEH3126	3-wire	1 S0-impulse output	2 tariffs	+/- kWh / kvarh	10 (63) A . . . . .329
EEH3176	3-wire	1 S0-impulse output	LCD, 2 tariffs	+/- kWh / kvarh	10 (63) A . . . . .330
EMU4114	4-wire	1 S0-impulse output		kWh	5 (63) A . . . . .331
EMU4124	4-wire	1 S0-impulse output	2 tariffs, HT-NT	kWh	5 (63) A . . . . .332
EMU4154	4-wire	1 S0-impulse output	LCD	kWh	5 (63) A . . . . .333
EMU4174	4-wire	1 S0-impulse output	LCD, 2 tariffs, HT-NT	kWh	5 (63) A . . . . .334
EMU4754	4-wire	1 S0-impulse output	LCD, M-BUS	kWh	5 (63) A . . . . .335
EMU4774	4-wire	1 S0-impulse output	LCD, M-BUS, 2 tariffs	kWh	5 (63) A . . . . .336
EMU4164	4-wire	1 S0-impulse output	LCD, 2 tariffs, HT-NT	kWh	5 (63) A . . . . .337

### Three-phase energy transformer meter, clip-on to 35 mm DIN rail

EEH4115	4-wire	1 S0-impulse output		kWh / kvarh	5 A, 1 A . . . . .338
EEH4125	4-wire	1 S0-impulse output	2 tariffs	+/- kWh / kvarh	5 A, 1 A . . . . .339
EEH4175	4-wire	1 S0-impulse output	LCD, 2 tariffs	+/- kWh / kvarh	5 A, 1 A . . . . .340
EEH3115	3-wire	1 S0-impulse output		kWh / kvarh	5 A, 1 A . . . . .341
EEH3125	3-wire	1 S0-impulse output	2 tariffs	+/- kWh / kvarh	5 A, 1 A . . . . .342
EEH3175	3-wire	1 S0-impulse output	LCD, 2 tariffs	+/- kWh / kvarh	5 A, 1 A . . . . .343
EMU4115	4-wire	1 S0-impulse output		kWh	5 A . . . . .344
EMU4125	4-wire	1 S0-impulse output	2 tariffs, HT-NT	kWh	5 A . . . . .345
EMU4155	4-wire	1 S0-impulse output	LCD	kWh	5 A . . . . .346
EMU4175	4-wire	1 S0-impulse output	LCD, 2 tariffs, HT-NT	kWh	5 A . . . . .347
EMU4755	4-wire	1 S0-impulse output	LCD, M-BUS	kWh	5 A . . . . .348
EMU4775	4-wire	1 S0-impulse output	LCD, M-BUS, 2 tariffs	kWh	5 A . . . . .349
EMU4165	4-wire	1 S0-impulse output	LCD, 2 tariffs, HT-NT	kWh	5 A . . . . .350



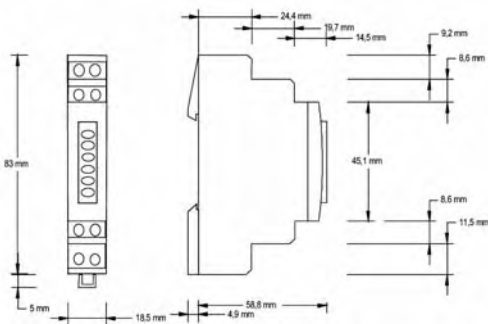
# EAA7112

## Single-phase energy meter

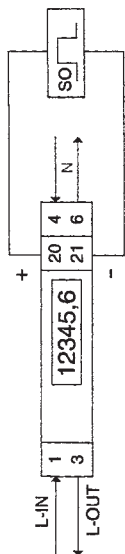
Calibrated AC energy meter for clip-on to 35 mm DIN rail



drawing



connection diagram



<b>Type of energy meter</b>	AAD1D5F	
-----------------------------	---------	--

<b>Mains</b>	2-wire	L-N (230 V)
	rated voltage $U_N$	230 V AC, 50 Hz
	tolerance value:	-20 %...+15 %
	frequency	50 Hz

<b>Output</b>	1 S0-impulse output	
	optocoupler	5-30 V DC / 20 mA max.
(S0+/S0-)	impulse duration	50 ms
collector open	output impulse	1000 Imp/kWh
	impedance	100 Ohm
	connection terminal	S0-, S0+

<b>Counter</b>	1 counter meter for active energy (kWh)	
	electro-mechanical meter	
	number of digits:	7 (6.1 digits)
	digit height:	4 mm
	digit width:	1.2 mm
	function control	red flashing LED 2.000 Imp/kWh

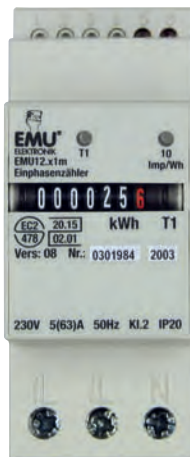
<b>Current range</b>	5 (32) A	
	nominal current $I_N$	5 A
	max. current ( $I_{max}$ )	32 A
	start current	0.004 $I_N$
	energy consumption	0.4 W/current path

### Technical data

approbations	PTB approval
accuracy class	class 1, DIN EN 61036, active energy
ambient temperature	-10 °C to +45 °C
protection class	IP 50
connections	IP 20
	main connections 1...6 mm <sup>2</sup>
	SO-impulse output max. 2.5 mm <sup>2</sup>
	main connections M4,
	S0 M3
	Pozidrive Phillips no. 1, flat no. 1
screw terminals	
	dimensions (mm)
	17.5 x 85 x 59
	weight
	0.08 kg
	isolation characteristics
	4 kV / 50 Hz, test acc. to VDE 0435
	surge voltage acc. to IEC 255-4:
	6 kV 1.2/50 ms
	protection class 2
EMV/interference stability	
	4 kV 1.2/50 ms
	surge voltage stability
	acc. to IEC 1000-4-5 at input
	1 kV 1.2/50 ms
	surge voltage stability
	acc. to IEC 1000-4-5 at output
	SO
	burst acc. to IEC 1000-4-4
	level 4 (4 kV)
	electro static discharge (ESD)
	acc. to IEC 1000-4-2
	level 3 (8 kV)

# EMU7114

## Single-phase energy meter



Calibrated AC energy meter for clip-on to 35 mm DIN rail

**Type of energy meter** EMU12.x1 m

Mains	2-wire	L-N (230 V)
	rated voltage $U_N$	230 V
	tolerance value	-20 %...+20 %
	frequency	50 Hz
	frequency range	45-65 Hz

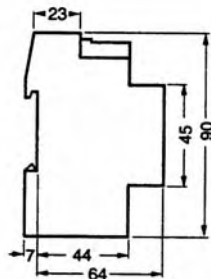
Output	1 S0-impulse output	
	optocoupler	5-30 V DC / 20 mA max.
(S0+/S0-)	impulse duration	125 ms
collector open	output impulse	10 Imp/kWh
	impedance	0.5-1.5 kOhm
	connection terminal	5 / 6

Counter	1 counter meter for active energy (kWh)	
	1 electro-mechanical meter	
	number of digits	7 (6.1 digits)
	digit height	4 mm
	digit width	1.2 mm
	operating display	green LED
	LED test	10 Imp/Wh (invisible)

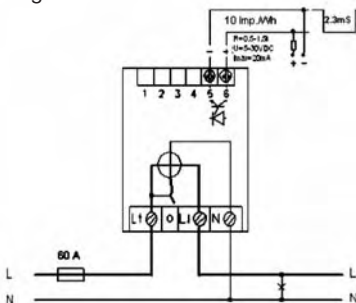
Current range	5 (63) A	
	nominal current $I_N$	5 A
	max. current $I_{max}$	63 A
	consumption	0.8 W/current path
	start current	0.005 $I_N$

Technical data		
approbations	PTB approval	
accuracy class	class 2, DIN EN 61036, active energy	
ambient temperature	-10 °C to +50 °C	
protection class	IP 50	
connections	IP 20	
connections		
main connection	1...10 mm <sup>2</sup>	
S0-impulse output	max. 2.5 mm <sup>2</sup>	
dimensions (mm)	36 x 90 x 71	
weight	0.15 kg	

drawing



diagram



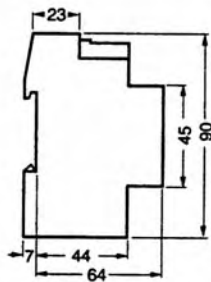
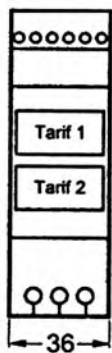
# EMU7124

## Single-phase energy meter

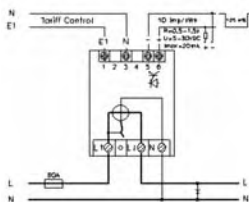


photo is similar to the original

drawing



diagram



Calibrated AC energy meter for clip-on to 35 mm DIN rail

**Type of energy meter** EMU12.x2m

<b>Mains</b>	2-wire	L-N (230 V)
	rated voltage $U_N$	230 V
	tolerance value	-20 %...+20 %
	frequency	50 Hz
	frequency range	45-65 Hz

**Output** 1 SO-impulse output

(S0+/S0-)	optocoupler	5-30 V DC / 20 mA max.
collector open	impulse duration	125 ms
	output impulse	10 Imp/kWh
	impedance	0.5 – 1.5 kOhm
	connection terminal	5 / 6

**Counter** 2 counter meters for active energy HT-NT (kWh)

2 electro-mechanical meters	
number of digits	7 (6.1 digits)
digit height	4 mm
digit width	1.2 mm
operating display	green LED
LED test	10 Imp/Wh (invisible)

**Current range** 5 (63) A

nominal current $I_N$	5 A
max. current $I_{max}$	63 A
consumption	0.8 W/current path
start current	0.005 $I_N$

**Technical data**

approbations	PTB approval
accuracy class	class 2, DIN EN 61036, active energy
ambient temperature	-10 °C to +50 °C
protection class	IP 50
connections	IP 20
connections	
main connection	1 ... 10 mm <sup>2</sup>
SO-impulse output	max. 2.5 mm <sup>2</sup>
dimensions (mm)	36 x 90 x 71
weight	0.17 kg
tariff start	230 V AC
Tariff 2 is energized when terminals 1 and 3 are under load of 230 V AC.	

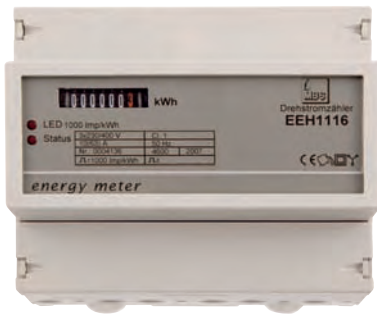


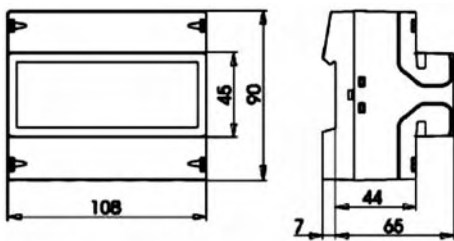
photo is similar to the original

# EEH4114

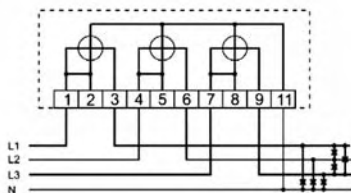
## Three-phase energy meter

Calibrated AC energy meter for clip-on to 35 mm DIN rail

drawing



diagram



<b>Type of energy meter</b>	EEH4114	
-----------------------------	---------	--

<b>Mains</b>	4-wire	L-N (230 V)
	rated voltage $U_N$	230 V
	tolerance value	-20 %...+15 %
	consumption	< 3.0 W/phase
	frequency	50 Hz
	frequency range	45 ... 65 Hz

<b>Output</b>	1 S0-impulse output	
---------------	---------------------	--

(S0)	optocoupler	40 V / 27 mA max.
collector open	impulse duration	100 ms +/-50 %
	output impulse	1000 Imp/kWh
	connection terminal	40 / 41

(option)	communication	
----------	---------------	--

	RS485 connection	EEH4314 multi-drop
	cable type	screened, wound pair
	max. cable length	1000 m
	connection	terminal screw
	isolation	3.7 kV rms for 1 min. between all meters and other units
	transmission system	asynchronous
	format type	MODBUS RTU
	transmission time	1200 to 19200 bits/s
	connection A and B	120 Ohm
	max. linked meters	32

<b>Counter</b>	1 counter meter for active energy (kWh)	
----------------	---	--

	electro-mechanical meter	
	number of digits	7 (6.1 digits)
	digit height	4 mm
	digit width	1.2 mm
	LED test	1000 Imp/kWh (red)
	LED operation	status (red)

(option)	1 meter for reactive energy (kvarh)	
----------	-------------------------------------	--

	EEH4104	
--	---------	--

<b>Current range</b>	5 (63) A	
----------------------	----------	--

	nominal current $I_N$	5 A
	max. current $I_{max}$	63 A
	consumption	< 0.02 W/current path
	start current	0.004 $I_N$

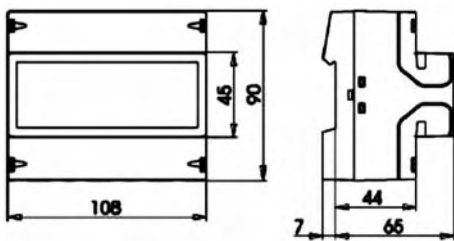
<b>Technical data</b>		
-----------------------	--	--

approbations	PTB approval applied for	
active energy	EN 61036 class 1	
reactive energy	EN 61268 class 2	
construction	housing	PA6.6 in conformity with UL 94 V-0
	dimensions (mm)	108 x 90 x 72
	weight	0.6 kg
	mounting	DIN rail acc. to DIN EN 50022
ambient temperature	climatic conditions	EN 61036 interior meter
	operation	-20 °C to +55 °C
	storage	-25 °C to +70 °C
	protection class	2
	current terminals	< 16 mm <sup>2</sup>
	control terminals	< 2.5 mm <sup>2</sup>

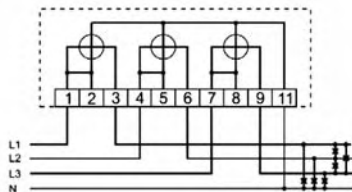


photo is similar to the original

drawing



diagram



# EEH4124

## Three-phase energy meter

Calibrated AC energy meter for dual tariff for clip-on to 35 mm DIN rail

<b>Type of energy meter</b>	EEH4124	
-----------------------------	---------	--

<b>Mains</b>	4-wire	L-N (230 V)
	rated voltage $U_N$	230 V
	tolerance value	-20 %...+15 %
	consumption	< 3.0 VA
	frequency	50 Hz
frequency range	45...65 Hz	

<b>Output</b>	1 S0-impulse output	
	optocoupler	40 V / 27 mA max.
	impulse duration	100 ms +/-50 %
	collector open	output impulse
	connection terminal	40 / 41 / 42

(option)	communication	RS485	EEH4424
		connection	multi-drop
		cable type	screened, wound pair
		max. cable length	1000 m
		connection	terminal screw
		isolation	3.7 kV rms for 1 min. between all meters and other units
		transmission system	asynchronous
		format type	MODBUS RTU
		transmission time	1200 to 19200 bits/s
		connection A and B	120 Ohm
	max. linked meters	32	

<b>Counter</b>	2 counter meters for active energy HT-NT	
----------------	--	--

	2 electro-mechanical meters	
	number of digits	7 (6.1 digits)
	digit height	4 mm
	digit width	1.2 mm
	LED test	1000 Imp/kWh (red)
	LED operation	status (tariffs) (red)

(option)	2 meters for active/reactive energy (kvarh)	EEH4234
	2 meters for active energy (import/export)	EEH4244

<b>Current range</b>	5 (63) A	
----------------------	----------	--

	nominal current $I_N$	5 A
	max. current $I_{max}$	63 A
	consumption	< 0.02 VA/current path
	start current	0.004 $I_N$

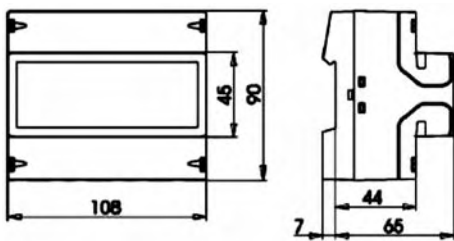
<b>Technical data</b>		
-----------------------	--	--

construction	approbations	PTB approval applied for
	active energy	EN 61036 class 1
	reactive energy	EN 61268 class 2
	housing	PA6.6 in conformity with UL 94 V-0
	dimensions (mm)	108 x 90 x 72
ambient temperature	weight	0.6 kg
	mounting	DIN rail acc. to DIN EN 50022
operation	climatic conditions	EN 61036 interior meter
	operation	-20 °C to +55 °C
	storage	-25 °C to +70 °C
	protection class	2
	current terminals	< 16 mm <sup>2</sup>
	control terminals	< 2.5 mm <sup>2</sup>
	tariff start	230 V AC
	Tariff 2 is energized when terminals 13 and 15 are under load of 230 V AC.	

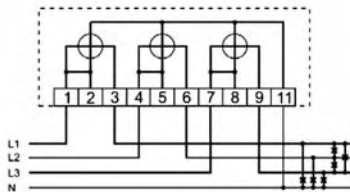


photo is similar to the original

drawing



diagram



# EEH4174

## Three-phase energy meter

Calibrated AC energy meter for dual tariff for clip-on to 35 mm DIN rail

<b>Type of energy meter</b>	EEH4174	
-----------------------------	---------	--

<b>Mains</b>	4-wire	L-N (230 V)
	rated voltage $U_N$	230 V
	tolerance value	-20 %...+15 %
	consumption	< 3.0 W/phase
	frequency	50 Hz
	frequency range	45...65 Hz

<b>Output</b>	1 S0-impulse output	
	optocoupler	40 V / 27 mA max.
	(S0) impulse duration	100 ms +/-50 %
	collector open	output impulse 1000 Imp/kWh connection terminal 40 / 41

(option)	communication	RS485	EEH4474
		connection	multi-drop
		cable type	screened, wound pair
		max. cable length	1000 m
		connection	terminal screw
		isolation	3.7 kV rms for 1 min. between all meters and other units
		transmission system	asynchronous
		format type	MODBUS RTU
		transmission time	1200 to 19200 bits/s
		connection A and B	120 Ohm
	max. linked meters	32	

<b>Counter</b>	LCD counter meter for active energy HT-NT (kWh)	
	number of digits	2 x 9 (8.1 digits)
	digit height	4.86 mm
	digit width	2.96 mm

(option)	2 meters for active/reactive energy (kvarh)	EEH4284
	2 meters for active energy (import/export)	EEH4294

<b>Current range</b>	5 (63) A	
	nominal current $I_N$	5 A
	max. current $I_{max}$	63 A
	consumption	< 0.02 W/current path
	start current	0.004 $I_N$

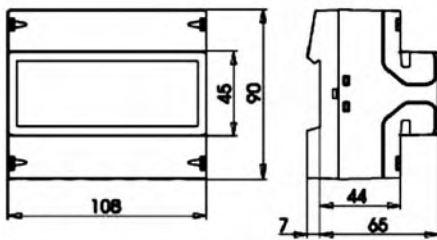
<b>Technical data</b>		
-----------------------	--	--

construction	approbations	PTB approval applied for
	active energy	EN 61036 class 1
	reactive energy	EN 61268 class 2
	housing	PA6.6 in conformity with UL 94 V-0
	dimensions (mm)	108 x 90 x 72
ambient temperature	weight	0.6 kg
	mounting	DIN rail acc. to DIN EN 50022
	climatic conditions	EN 61036 interior meter
	operation	-20 °C to +55 °C
	storage	-25 °C to +70 °C
	protection class	2
	current terminals	< 16 mm <sup>2</sup>
	control terminals	< 2.5 mm <sup>2</sup>
	tariff start	230 V AC
	Tariff 2 is energized when terminals 13 and 15 are under load of 230 V AC.	

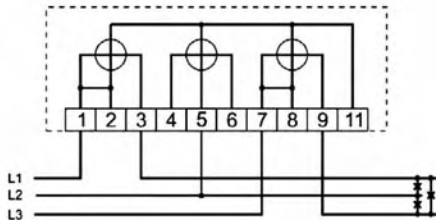


photo is similar to the original

drawing



diagram



# EEH3116

## Three-phase energy meter

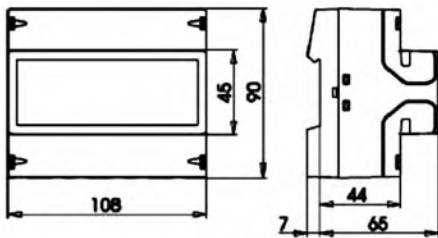
Calibrated AC energy meter for clip-on to 35 mm DIN rail

Type of energy meter		EEH3116	
<b>Mains</b>	3-wire	L-L (400 V)	
	rated voltage $U_N$	230 V	
	tolerance value	-20 %...+15 %	
	consumption	< 3.0 W/phase	
	frequency	50 Hz	
	frequency range	45 ... 65 Hz	
<b>Output</b>	1 S0-impulse output		
	optocoupler	40 V / 27 mA max.	
	impulse duration	100 ms +/-50 %	
	output impulse	1000 Imp/kWh	
(S0) collector open	connection terminal	40 / 41	
<b>(option)</b>	communication	RS485	
	connection	EEH3316	
		multi-drop	
		cable type	screened, wound pair
		max. cable length	1000 m
		connection	terminal screw
		isolation	3.7 kV rms for 1 min. between all meters and other units
		transmission system	asynchronous
		format type	MODBUS RTU
		transmission time	1200 to 19200 bits/s
		connection A and B	120 Ohm
	max. linked meters	32	
<b>Counter</b>	1 counter meter for active energy (kWh)		
	electro-mechanical meter		
	number of digits	7 (6.1 digits)	
	digit height	4 mm	
	digit width	1.2 mm	
	LED test	1000 Imp/kWh (red)	
	LED operation	status (red)	
<b>(option)</b>	1 meter for reactive energy (kvarh)	EEH3106	
<b>Current range</b>	nominal current $I_N$	10 (63) A	
	max. current $I_{max}$	63 A	
	consumption	< 0.02 W/current path	
	start current	0.004 $I_N$	
<b>Technical data</b>	approbations	PTB approval applied for	
	active energy	EN 61036 class 1	
	reactive energy	EN 61268 class 2	
	construction	housing	PA6.6 in conformity with UL 94 V-0
		dimensions (mm)	108 x 90 x 72
		weight	0.6 kg
		mounting	DIN rail acc. to DIN EN 50022
		climatic conditions	EN 61036 interior meter
	ambient temperature	operation	-20 °C to +55 °C
		storage	-25 °C to +70 °C
		protection class	2
		current terminals	< 16 mm <sup>2</sup>
		control terminals	< 2.5 mm <sup>2</sup>

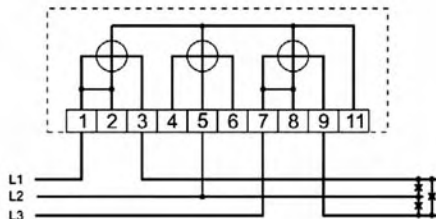


photo is similar to the original

drawing



diagram



# EEH3126

## Three-phase energy meter

Calibrated AC energy meter for dual tariff for clip-on to 35 mm DIN rail

<b>Type of energy meter</b>	EEH3126	
-----------------------------	---------	--

<b>Mains</b>	3-wire	L-L (400)V
	rated voltage $U_N$	230 V
	tolerance value	-20 %...+15 %
	consumption	< 3.0 VA
	frequency	50 Hz
	frequency range	45 ... 65 Hz

<b>Output</b>	1 S0-impulse output	
	optocoupler	40 V / 27 mA max.
	(S0) impulse duration	100 ms +/-50 %
	collector open	output impulse 1000 Imp/kWh connection terminal 40 / 41 / 42

(option)	communication	RS485	EEH3426
		connection	multi-drop
		cable type	screened, wound pair
		max. cable length	1000 m
		connection	terminal screw
		isolation	3.7 kV rms for 1 min. between all meters and other units
		transmission system	asynchronous
		format type	MODBUS RTU
		transmission time	1200 to 19200 bits/s
		connection A and B	120 Ohm
	max. linked meters	32	

<b>Counter</b>	2 counter meters for active energy HT-NT (kWh)	
----------------	--	--

	2 electro-mechanical meters	
	number of digits	7 (6.1 digits)
	digit height	4 mm
	digit width	1.2 mm
	LED test	1000 Imp/kWh (red)
	LED operation	status (tariffs) (red)

(option)	2 meters for active/reactive energy (kvarh)	EEH3236
	2 meters for active energy (import/export)	EEH3246

<b>Current range</b>	10 (63) A	
----------------------	-----------	--

	nominal current $I_N$	10 A
	max. current $I_{max}$	63 A
	consumption	< 0.02 VA/current path
	start current	0.004 $I_N$

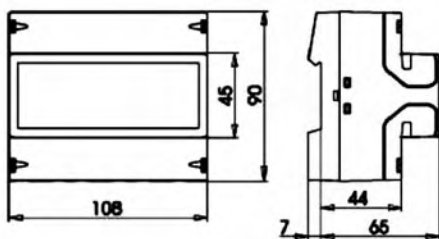
<b>Technical data</b>		
-----------------------	--	--

construction	approbations	PTB approval applied for
	active energy	EN 61036 class 1
	reactive energy	EN 61268 class 2
	housing	PA6.6 in conformity with UL 94 V-0
	dimensions (mm)	108 x 90 x 72
ambient temperature	weight	0.6 kg
	mounting	DIN rail acc. to DIN EN 50022
	climatic conditions	EN 61036 interior meter
	operation	-20 °C to +55 °C
	storage	-25 °C to +70 °C
	protection class 2	
	current terminals	< 16 mm <sup>2</sup>
	control terminals	< 2.5 mm <sup>2</sup>
	tariff start	230 V AC
	Tariff 2 is energized when terminals 13 and 15 are under load of 230V AC.	

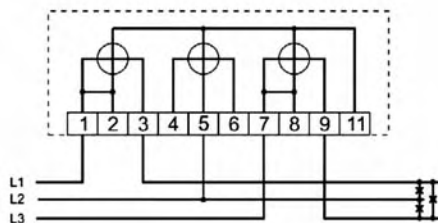


photo is similar to the original

drawing



diagram



# EEH3176

## Three-phase energy meter

Calibrated AC energy meter for dual tariff for clip-on to 35 mm DIN rail

### Type of energy meter EEH3176

Mains	3-wire	L-L (400 V)
rated voltage $U_N$		230 V
tolerance value		-20 %...+15 %
consumption		< 3.0 W/phase
frequency		50 Hz
frequency range		45 ... 65 Hz

### Output 1 S0-impulse output

(S0)	optocoupler	40 V / 27 mA max.
collector open	impulse duration	100 ms +/-50 %
	output impulse	1000 Imp/kWh
	connection terminal	40 / 41

### (option) communication

communication	RS485	EEH3476
	connection	multi-drop
	cable type	screened, wound pair
	max. cable length	1000 m
	connection	terminal screw
	isolation	3.7 kV rms for 1 min. between all meters and other units
	transmission system	asynchronous
	format type	MODBUS RTU
	transmission time	1200 to 19200 bits/s
	connection A and B	120 Ohm
	max. linked meters	32

### Counter LCD counter meter for active energy HT-NT (kWh)

	number of digits	2 x 9 (8.1 digits)
	digit height	4.86 mm
	digit width	2.96 mm

### (option)

2 counter meters for active/reactive energy (kWh/kvarh)	EEH3286
2 counter meters for reactive energy (import/export) (kWh)	EEH3296

### Current range 10 (63) A

	nominal current $I_N$	10 A
	max. current $I_{max}$	63 A
	consumption	< 0.02 W/current path
	start current	0.004 $I_N$

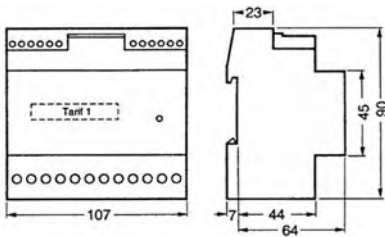
### Technical data

	approbations	PTB approval applied for
	active energy	EN 61036 class 1
	reactive energy	EN 61268 class 2
construction	housing	PA6.6 in conformity with UL 94 V-0
	dimensions (mm)	108 x 90 x 72
	weight	0.6 kg
	mounting	DIN rail acc. to DIN EN 50022
	climatic conditions	EN 61036 interior meter
ambient temperature	operation	-20 °C to +55 °C
	storage	-25 °C to +70 °C
	protection class	2
	current terminals	< 16 mm <sup>2</sup>
	control terminals	< 2.5 mm <sup>2</sup>
	tariff start	230 V AC
	Tariff 2 is energized when terminals 13 and 15 are under load of 230 V AC.	

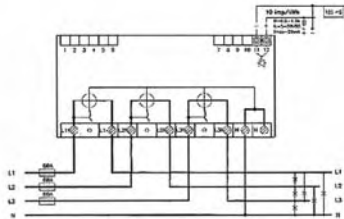


photo is similar to the original

drawing



diagram



# EMU4114

## Three-phase energy meter

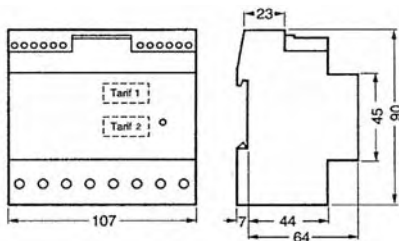
Calibrated AC energy meter for clip-on to 35 mm DIN rail

<b>Type of energy meter</b>		EEH4114
<b>Mains</b>		4-wire L-N (230 V) rated voltage $U_N$ 230 V tolerance value -20 %...+20 % consumption 0.8 W/current path frequency 50 Hz frequency range 45...65 Hz
<b>Output</b>		1 S0-impulse output optocoupler 5-30 V DC / 20 mA max. impulse duration approx. 125 ms collector open output impulse 10 Imp/kWh impedance 0.5 – 1.5 kOhm connection terminal 11 / 12
<b>Counter</b>		1 counter meter for active energy (kWh) 1 electro-mechanical meter number of digits 7 (6.1 digits) digit height 5 mm digit width 3 mm LED test 10 Imp/Wh (invisible) LED operation status (green)
<b>Current range</b>		5 (63) A nominal current $I_N$ 5 A max. current $I_{max}$ 63 A consumption 0.8 W/current path start current 0.005 $I_N$
<b>Technical data</b>		approbations PTB approval accuracy class class 2, EN 61036, active energy dimensions (mm) 107 x 90 x 71 weight 0.35 kg mounting DIN rail acc. to DIN EN 50022-35 climatic conditions EN 61036 interior meter ambient temperature operation -10 °C to +50 °C storage -40 °C to +70 °C protection class 2 current terminals 7.6 x 8.3 mm control terminals 2.5 x 3 mm

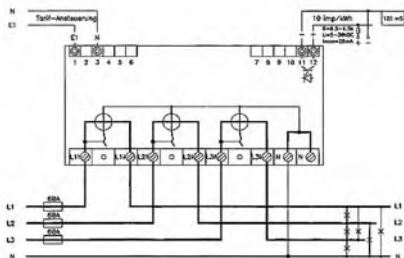


photo is similar to the original

drawing



diagram



# EMU4124

## Three-phase energy meter

Calibrated AC energy meter for dual tariff for clip-on to 35 mm DIN rail

<b>Type of energy meter</b>	EMU4124	
<b>Mains</b>	4-wire rated voltage $U_N$ tolerance value consumption frequency frequency range	L-N (230 V) 230 V -20 %...+20 % 0.8 W/phase 50 Hz 45 ... 65 Hz
<b>Output</b>	1 S0-impulse output (S0) collector open	optocoupler impulse duration output impulse impedance connection terminal
		5-30 V DC / 20 mA max. approx. 125 ms 10 Imp/kWh 0.5 – 1.5 kOhm 11 / 12
<b>Counter</b>	2 counter meters for active energy HT-NT (kWh)	
	2 electro-mechanical meters	
	number of digits	7 (6.1 digits)
	digit height	4 mm
	digit width	1.2 mm
	LED test	10 Imp/Wh (invisible)
	LED operation	status (tariffs) (green)
<b>Current range</b>	5 (63) A	
	nominal current $I_N$	5 A
	max. current $I_{max}$	63 A
	consumption	0.8 W/current path
	start current	0.005 $I_N$
<b>Technical data</b>	approbations PTB approval accuracy class class 2, EN 61036, active energy dimensions (mm) 107 x 90 x 71 weight 0.40 kg mounting DIN rail acc. to DIN EN 50022-35 climatic conditions EN 61036 interior meter operation -10 °C to +50 °C storage -40 °C to +70 °C protection class 2 current terminals 7.6 x 8.3 mm control terminals 2.5 x 3 mm tariff control 230 V AC Tariff 2 is energized when terminals 1 and 3 are under load of 230 V AC.	
ambient temperature		

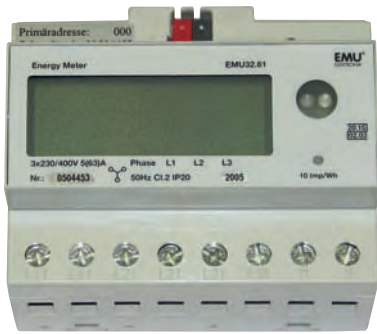
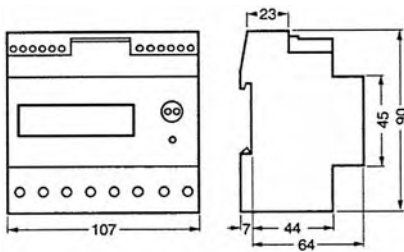
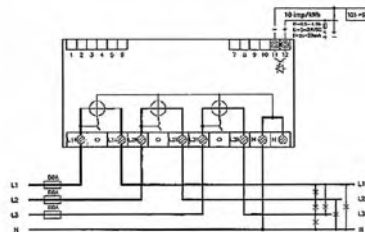


photo is similar to the original

drawing



diagram



# EMU4154

## Three-phase energy meter

Calibrated AC energy meter for clip-on to 35 mm DIN rail

<b>Type of energy meter</b>	EMU4154	
<b>Mains</b>	4-wire	L-N (230 V)
	rated voltage $U_N$	230 V
	tolerance value	-20 %...+20 %
	consumption	0.8 W/phase
	frequency	50 Hz
	frequency range	45 ... 65 Hz
<b>Output</b>	1 S0-impulse output	
	optocoupler	5-30 V DC / 20 mA max.
(S0)	impulse duration	approx. 125 ms
collector open	output impulse	10 Imp/kWh
	impedance	0.5-1.5 kOhm
	connection terminal	11 / 12
<b>Counter</b>	LCD counter meter for active energy (kWh)	
	LCD display	rolling display
	counter indication kWh for T1	display duration 15 s
		number of digits 7 (6.1 digits)
		digit height 8 mm
		digit width 4.5 mm
	unit no.	display duration 2 s
		customer specific data can be programmed at works
	software version	display duration 2 s
	segment test	display duration 2 s
	energy flow	supply stopped two-way flow
	operating display	3 arrows at lower end of LCD
	LED test	10 Imp/Wh (invisible)
<b>Current range</b>	5 (63) A	
	nominal current $I_N$	5 A
	max. current $I_{max}$	63 A
	consumption	0.8 W/current path
	start current	0.005 $I_N$
<b>Technical data</b>		
	approbations	PTB approval
	accuracy class	class 2, EN 61036, active energy
	dimensions (mm)	107 x 90 x 71
	weight	0.35 kg
	mounting	DIN rail acc. to DIN DIN EN 50022-35
	climatic conditions	EN 61036 interior meter
ambient	operation	-10 °C to +50 °C
temperature	storage	-40 °C to +70 °C
	protection class	2
	current terminals	7.6 x 8.3 mm
	control terminals	2.5 x 3 mm
	interface	optical interface
		acc. to IEC 61107

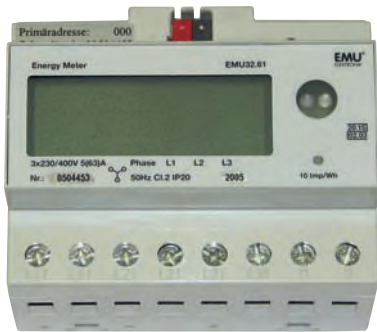
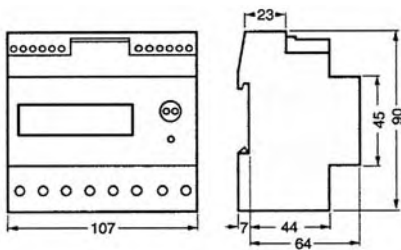
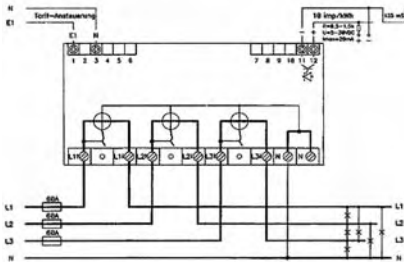


photo is similar to the original

drawing



diagram



# EMU4174

## Three-phase energy meter

Calibrated AC energy meter for dual tariff for clip-on to 35 mm DIN rail

<b>Type of energy meter</b>	EMU4174	
<b>Mains</b>	4-wire	L-N (230 V)
	rated voltage $U_N$	230 V
	tolerance value	-20 %...+20 %
	consumption	0.8 W/phase
	frequency	50 Hz
	frequency range	45 ... 65 Hz
<b>Output</b>	1 S0-impulse output	
(S0) I	optocoupler	5-30 V DC / 20 mA max.
collector open	impulse duration	approx. 125 ms
	output impulse	10 Imp/kWh
	impedance	0.5-1.5 kOhm
	connection terminal	11 / 12
<b>Counter</b>	LCD counter meter for active energy HT-NT (kWh)	
	LCD display	rolling display
	counter indication kWh for T1	display duration 15 s
		number of digits 7 (6.1 digits)
		digit height 8 mm
		digit width 4.5 mm
	counter indication kWh for T2	display duration 15 s
	unit no.	display duration 2 s
		customer specific data can be programmed at works
	software version	display duration 2 s
	segment test	display duration 2 s
	energy flow	supply stopped two-way flow
	operating display	3 arrows at lower end of LCD
	LED test	10 Imp/Wh (not visible)
<b>Current range</b>	5 (63) A	
	nominal current $I_N$	5 A
	max. current $I_{max}$	63 A
	consumption	0.8 W/current path
	start current	0.005 $I_N$
<b>Technical data</b>		
	approbations	PTB approval
	accuracy class	class 2, EN 61036, active energy
	dimensions (mm)	107 x 90 x 71
	weight	0.35 kg
	mounting	DIN rail acc. to DIN EN 50022-35
	climatic conditions	EN 61036 interior meter
ambient	operation	-10 °C to +50 °C
temperature	storage	-40 °C to +70 °C
	protection class	2
	current terminals	7.6 x 8.3 mm
	control terminals	2.5 x 3 mm
	interface	optical interface acc. to IEC 61107
	tariff control	230 V AC
		Tariff 2 is energized when terminals 1 and 3 are under load of 230 V AC.

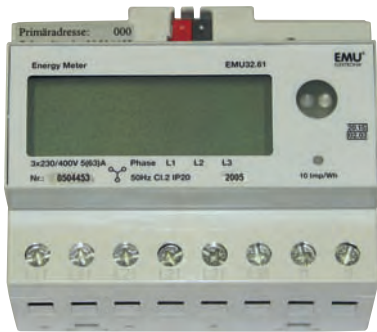
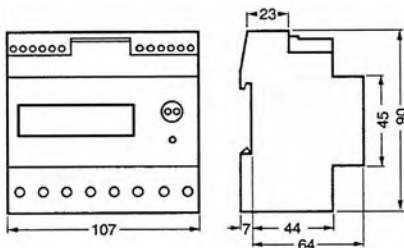
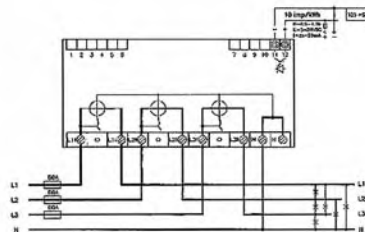


photo is similar to the original

drawing



diagram



# EMU4754

## Three-phase energy meter M-BUS

Calibrated AC energy meter for clip-on to 35 mm DIN rail

<b>Type of energy meter</b>	EMU4754	
<b>Mains</b>	4-wire	L-N (230 V)
	rated voltage $U_N$	230 V
	tolerance value	-20 %...+20 %
	consumption	0.8 W/phase
	frequency	50 Hz
	frequency range	45 ... 65 Hz
<b>Output</b>	1 S0-impulse output and M-Bus output	
	optocoupler	5-30 V DC / 20 mA max.
(S0)	impulse duration	approx. 125 ms
collector open	output impulse	10 Imp/kWh
	impedance	0.5 – 1.5 kOhm
	connection terminal	11 / 12
	M-BUS data selection	current system time of the meter operation hours of the meter total active energy actual active power number of voltage interruptions error/ flag .../ time indication of the last power cut
<b>Counter</b>	LCD counter meter for active energy (kWh)	
	LCD display	rolling display
	counter indication kWh for T1	display duration 15 s number of digits 7 (6.1 digits) digit height 8 mm digit width 4.5 mm
	unit no.	display duration 2 s customer specific data can be programmed at works
	software version	display duration 2 s
	segment test	display duration 2 s
	energy flow	supply stopped two-way flow
	operating display	3 arrows at lower end of LCD
	LED test	10 Imp/Wh (invisible)
<b>Current range</b>	5 (63) A	
	nominal current $I_N$	5 A
	max. current $I_{max}$	63 A
	consumption	0.8 W/current path
	start current	0.005 $I_N$
<b>Technical data</b>	approbations PTB approval, applied for active energy accuracy class class 2, EN 61036 dimensions (mm) 107 x 90 x 71 weight 0.35 kg mounting DIN rail acc. to DIN EN 50022-35 climatic conditions EN 61036 interior meter operation -10 °C to +50 °C storage -40 °C to +70 °C protection class 2 current terminals 7.6 x 8.3 mm control terminals 2.5 x 3 mm interface optical interface acc. to IEC 61107	

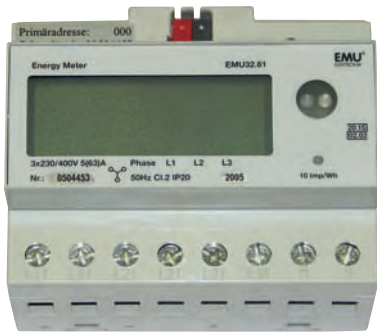
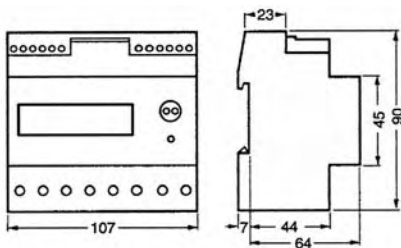
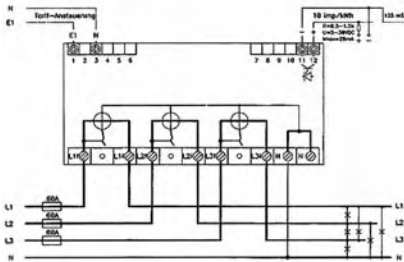


photo is similar to the original

drawing



diagram



# EMU4774

## Three-phase energy meter M-BUS

Calibrated AC energy meter for dual tariff for clip-on to 35 mm DIN rail

**Type of energy meter** EMU4774

<b>Mains</b>	4-wire	L-N (230 V)
	rated voltage $U_N$	230 V
	tolerance value	-20 %...+20 %
	consumption	0.8 W/phase
	frequency	50 Hz
	frequency range	45 ... 65 Hz

**Output** 1 impulse output and M-BUS output

(S0)	optocoupler	5-30 V DC / 20 mA max.
collector open	impulse duration	approx. 125 ms
	output impulse	10 Imp/kWh
	impedance	0.5 – 1.5 kOhm
	connection terminal	11 / 12
	M-BUS data selection	current system time of the meter operation hours of the meter total active energy actual active power number of voltage interruptions error/ flag .../ time indication of the last power cut

**Counter** LCD counter meter for active energy HT-NT (kWh)

	LCD display	rolling display
	counter indication kWh for T1	display duration 15 s number of digits 7 (6.1 digits) digit height 8 mm digit width 4.5 mm
	counter indication kWh for T2	display duration 15 s
	unit no.	display duration 2 s
	software version	customer specific data can be programmed at works
	segment test	display duration 2 s
	energy flow	display duration 2 s
	operating display	supply stopped two-way flow
	LED test	3 arrows at lower end of LCD 10 Imp/Wh (invisible)

**Current range** 5 (63) A

	nominal current $I_N$	5 A
	max. current $I_{max}$	63 A
	consumption	0.8 W/current path
	start current	0.005 $I_N$

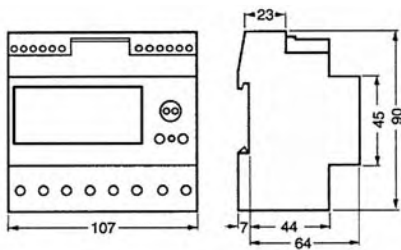
**Technical data**

	approbations	PTB approval, applied for active energy
	accuracy class	class 2, EN 61036
	dimensions (mm)	107 x 90 x 71
	weight	0.35 kg
	mounting	DIN rail acc. to DIN EN 50022-35
	climatic conditions	EN 61036 interior meter
ambient temperature	operation	-10 °C to +50 °C
	storage	-40 °C to +70 °C
	protection class	2
	current terminals	7.6 x 8.3 mm
	control terminals	2.5 x 3 mm
	interface	optical interface acc. to IEC 61107
	tariff control	230 V AC
	Tariff 2 is energized when terminals 1 and 3 are under load of 230 V AC.	

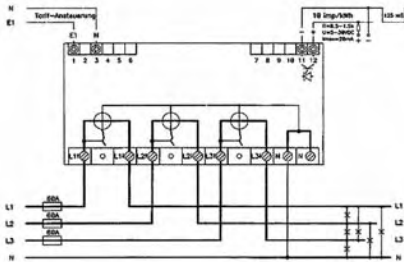


photo is similar to the original

drawing



diagram



# EMU4164

## Three-phase energy meter

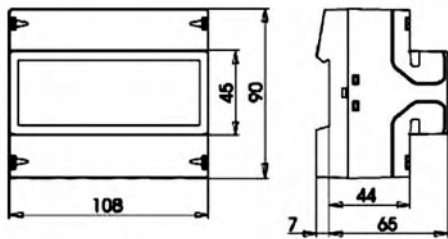
Calibrated AC energy meter for dual tariff for clip-on to 35 mm DIN rail

<b>Type of energy meter</b>	EMU4164	
<b>Mains</b>	4-wire rated voltage $U_N$ tolerance value consumption frequency frequency range	L-N (230 V) 230 V -20 %...+20 % 0.8 W/phase 50 Hz 45 ... 65 Hz
<b>Output</b>	1 S0-impulse output (S0) collector open	optocoupler impulse duration output impulse impedance connection terminal
<b>Counter</b>	LCD counter meter for active energy/active power HT-NT (kWh)	LCD display active energy (T1)  active energy (T2) present active power present voltage present current unit no. LED test
<b>Current range</b>	5 (63) A nominal current $I_N$ max. current $I_{max}$ consumption start current	counter (push black button to operate) kWh, price/kWh, total price 7 (6.1) digits 4.5 x 8 mm kWh, price/kWh total price kW total, kW L1-L2-L3 V L1-L2-L3 A total, A L1-L2-L3 5 digits 10 Imp/Wh (invisible)
<b>Technical data</b>	approbations accuracy class dimensions (mm) weight mounting climatic conditions operation storage protection class current terminals control terminals interface  tariff start Tariff 2 is energized when terminals 1 and 2 are under load of 230 V AC.	PTB approval class 2, EN 61036, active energy 107 x 90 x 71 0.35 kg DIN rail acc. to DIN EN 50022-35 EN 61036 interior meter -10 °C to +50 °C -40 °C to +70 °C 2 7.6 x 8.3 mm 2.5 x 3 mm optical interface acc. to IEC 61107 230 V AC

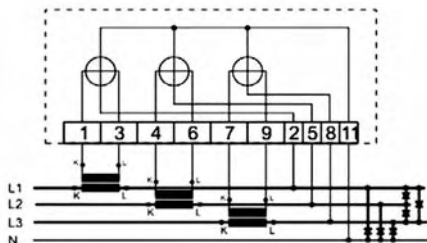


photo is similar to the original

drawing



diagram



# EEH4115

## Three-phase energy transformer meter

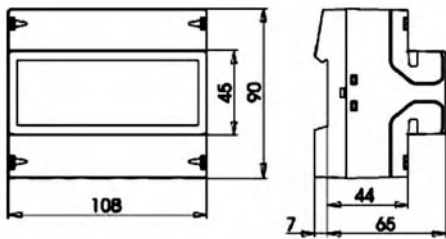
Calibrated AC energy transformer meter for clip-on to 35 mm DIN rail

<b>Type of energy meter</b>	EEH4115xxxx	
	xxxx declaring the primary current is absolutely necessary	
<b>Mains</b>	4-wire	L-N (230)V
	rated voltage $U_N$	230 V
	tolerance value	-20 %...+15 %
	consumption	< 3.0 VA
	frequency	50 Hz
	frequency range	45 ... 65 Hz
<b>Output</b>	1 S0-impulse output	
	optocoupler	40 V / 27 mA max.
(S0)	impulse duration	100 ms +/-50 %
collector open	output impulse	1000 Imp/kWh
	connection terminal	40 / 41
(option)	communication	
	RS485	EEH4315xxxx
	connection	multi-drop
	cable type	screened, wound pair
	max. cable length	1000 m
	connection	terminal screw
	isolation	3.7 kV rms for 1 min. between all meters and other units
	transmission system	asynchronous
	format type	MODBUS RTU
	transmission time	1200 to 19200 bits/s
	terminal A and B	120 Ohm
	max. linked meters	32
<b>Counter</b>	1 counter meter for active energy (kWh)	
	electro-mechanical meter	
	number of digits	7 (6.1 digits)
	digit height	4 mm
	digit width	1.2 mm
	LED test	1000 Imp/kWh (red)
	LED operation	status (red)
(option)	reactive energy	
		EEH3105xxxx
<b>Current range</b>	5 A	
	nominal current $I_N$	5 A
	max. current $I_{max}$	6 A
	consumption	< 0.02 VA/current path
	start current	0.002 $I_N$
(option)	nominal current $I_N$	1 A EEH3111xxxx
<b>Primary current</b>	0.5 A up to 2000 A	
	If not stated otherwise, the standard version 5 A or 1 A will be supplied	
<b>Technical data</b>		
construction	approbations	PTB approval applied for
	active energy	EN 61036 class 1
	reactive energy	EN 61268 class 2
	housing	PA6.6 in conformity with UL 94 V-0
ambient temperature	dimensions (mm)	108 x 90 x 72
	weight	0.6 kg
	mounting	DIN rail acc. to DIN DIN EN 50022
	climatic conditions	EN 61036 interior meter
ambient temperature	operation	-20 °C to +55 °C
	storage	-25 °C to +70 °C
	protection class	2
	current terminals	< 10 mm <sup>2</sup>
	control terminals	< 2.5 mm <sup>2</sup>

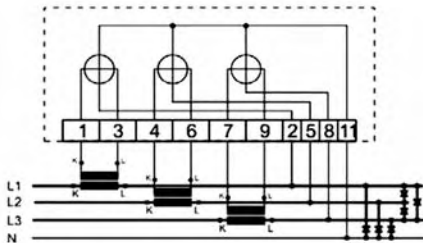


photo is similar to the original

drawing



diagram



# EEH4125

## Three-phase energy transformer meter

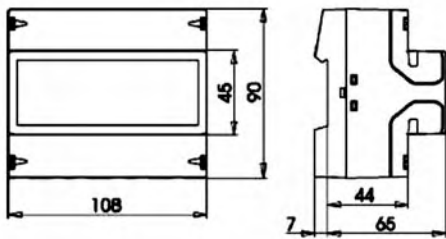
Calibrated AC energy transformer meter for dual tariff for clip-on to 35 mm DIN rail

<b>Type of energy meter</b>	EEH4125xxxx	
	xxxx declaring the primary current is absolutely necessary	
<b>Mains</b>	4-wire	L-N (230 V)
	rated voltage $U_N$	230 V
	tolerance value	-20 %...+15 %
	consumption	< 3.0 W/phase
	frequency	50 Hz
	frequency range	45 ... 65 Hz
<b>Output</b>	1 S0-impulse output	
	optocoupler	40 V / 27 mA max.
(S0)	impulse duration	100 ms +/-50 %
collector open	output impulse	1000 Imp/kWh
	connection terminal	40 / 41 / 42
(option)	communication	
	RS485	EEH4425xxxx
	connection	multi-drop
	cable type	screened, wound pair
	max. cable length	1000 m
	connection	terminal screw
	isolation	3.7 kV rms for 1 min. between all meters and other units
	transmission system	asynchronous
	format type	MODBUS RTU
	transmission time	1200 to 19200 bits/s
	terminal A and B	120 Ohm
	max. linked meters	32
<b>Counter</b>	2 counters for active energy HT-NT (kWh)	
	2 electro-mechanical counters	
	number of digits	7 (6.1 digits)
	digit height	4 mm
	digit width	1.2 mm
	LED test	1000 Imp/kWh (red)
	LED operation	status (tariffs) (red)
(option)	2 counters for active and reactive energy (kWh/kvarh) EEH4235xxxx	
	2 counters for active energy (import/export) (kWh) EEH4245xxxx	
<b>Current range</b>	5 A	
	nominal current $I_N$	5 A
	max. current $I_{max}$	6 A
	consumption	0.02 W/current path
	start current	0.002 $I_N$
(option)	nominal current $I_N$	1 A EEH4221xxxx
<b>Primary current</b>	0.5 A to 2000 A	
	If not stated otherwise, the standard version 5 A or 1 A will be supplied.	
<b>Technical data</b>		
	approbations	PTB approval applied for
	active energy	EN 61036 class 1
	reactive energy	EN 61268 class 2
construction	housing	PA6.6 in conformity with UL 94 V-0
	dimensions (mm)	108 x 90 x 72
	weight	0.6 kg
	mounting	DIN rail acc. to DIN EN 50022
	climatic conditions	EN 61036 interior meter
ambient temperature	operation	-20 °C to +55 °C
	storage	-25 °C to +70 °C
	protection class	2
	current terminals	< 10 mm <sup>2</sup>
	control terminals	< 2.5 mm <sup>2</sup>
	tariff start	230 V AC
	Tariff 2 is energized when terminals 13 and 15 are under load of 230 V AC.	

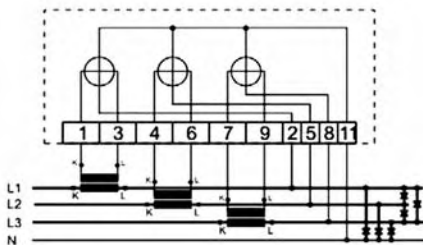


photo is similar to the original

drawing



diagram



# EEH4175

## Three-phase energy transformer meter

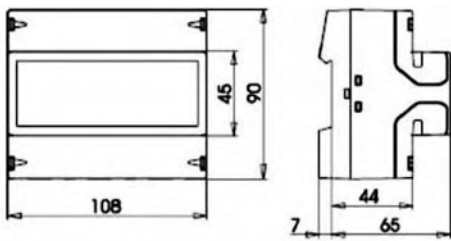
Calibrated AC energy transformer meter for clip-on to 35 mm DIN rail

<b>Type of energy meter</b>	EEH4175xxxx	
	xxxx declaring the primary current is absolutely necessary	
<b>Mains</b>	4-wire	L-N (230 V)
	rated voltage $U_N$	230 V
	tolerance value	-20 %...+15 %
	consumption	< 3.0 W
	frequency	50 Hz
	frequency range	45...65 Hz
<b>Output</b>	1 S0-impulse output	
	optocoupler	40 V / 27 mA max.
(S0) I	impulse duration	100 ms +/-50 %
collector open	output impulse	1000 Imp/kWh
	connection terminal	40 / 41
(option)	communication	
	RS485	EEH4475xxxx
	connection	multi-drop
	cable type	screened, wound pair
	max. cable length	1000 m
	connection	terminal screw
	isolation	3.7 kV rms for 1 min. between all meters and other units
	transmission system	asynchronous
	format type	MODBUS RTU
	transmission time	1200 to 19200 bits/s
	terminal A and B	120 Ohm
	max. linked meters	32
<b>Counter</b>	LCD counter meter for active energy HT-NT (kWh)	
	number of digits	2 x 9 (8.1 digits)
	digit height	4.86 mm
	digit width	2.96 mm
(option)	2 counters for active and reactive energy (kWh/kvarh) EEH4285xxxx	
	2 counters for active energy (import/export) (kWh) EEH4295xxxx	
<b>Current range</b>	5 A	
	nominal current $I_N$	5 A
	max. current $I_{max}$	6 A
	consumption	< 0.02 W/current path
	start current	0.002 $I_N$
(option)	nominal current $I_N$	1 A EEH4271xxxx
<b>Primary current</b>	0.5 A up to 2000 A	
	If not stated otherwise, the standard version 5 A or 1 A will be supplied	
<b>Technical data</b>		
	approbations	PTB approval applied for
	active energy	EN 61036 class 1
	reactive energy	EN 61268 class 2
construction	housing	PA.6.6 in conformity with UL 94 V-0
	dimensions (mm)	108 x 90 x 72
	weight	0.6 kg
	mounting	DIN rail acc. to DIN EN 50022
ambient temperature	climatic conditions	EN 61036 interior meter
	operation	-20 °C to +55 °C
	storage	-25 °C to +70 °C
	protection class	2
	current terminals	< 10 mm <sup>2</sup>
	control terminals	< 2.5 mm <sup>2</sup>
	tariff start	230 V AC
	Tariff 2 is energized when terminals 13 and 15 are under load of 230 V AC.	

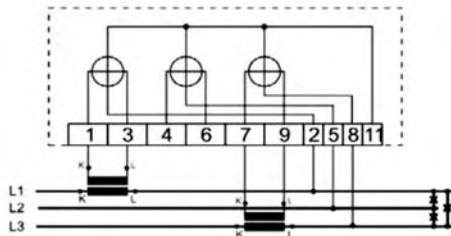


photo is similar to the original

drawing



diagram



# EEH3115

## Three-phase energy transformer meter

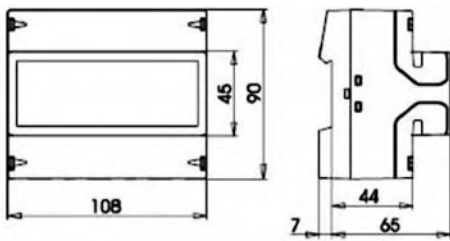
Calibrated AC energy transformer meter for clip-on to 35 mm DIN rail

<b>Type of energy meter</b>	EEH3115xxxx	
	xxxx declaring the primary current is absolutely necessary	
<b>Mains</b>	3-wire	L-L (400 V)
	rated voltage $U_N$	230 V
	tolerance value	-20 %...+15 %
	consumption	< 3.0 W/phase
	frequency	50 Hz
	frequency range	45 ... 65 Hz
<b>Output</b>	1 S0-impulse output	
	optocoupler	40 V / 27 mA max.
(S0)	impulse duration	100 ms +/-50 %
collector open	output impulse	1000 Imp/kWh
	connection terminal	40 / 41
(option)	communication	
	RS485	EEH3115xxxx
	connection	multi-drop
	cable type	screened, wound pair
	max. cable length	1000 m
	connection	terminal screw
	isolation	3.7 kV rms for 1 min. between all meters and other units
	transmission system	asynchronous
	format type	MODBUS RTU
	transmission time	1200 to 19200 bits/s
	terminal A and B	120 Ohm
	max. linked meters	32
<b>Counter</b>	1 counter meter for active energy (kWh)	
	electro-mechanical meter	
	number of digits	7 (6.1 digits)
	digit height	4 mm
	digit width	1.2 mm
	LED test	1000 Imp/kWh (red)
	LED operation	status (red)
(option)	reactive energy (kvarh)	EEH3105xxxx
<b>Current range</b>	5 A	
	nominal current $I_N$	5 A
	max. current $I_{max}$	6 A
	consumption	< 0.02 W/current path
	start current	0.002 $I_N$
(option)	nominal current $I_N$	1 A EEH3111xxxx
<b>Primary current</b>	0.5 A up to 2000 A	
	If not stated otherwise, the standard version 5 A or 1 A will be supplied.	
<b>Technical data</b>		
	approbations	PTB approval applied for
	active energy	EN 61036 class 1
	reactive energy	EN 61268 class 2
construction	housing	PA6.6 in conformity with UL 94 V-0
	dimensions (mm)	108 x 90 x 72
	weight	0.6 kg
	mounting	DIN rail acc. to DIN EN 50022
	climatic conditions	EN 61036 interior meter
ambient temperature	operation	-20 °C to +55 °C
	storage	-25 °C to +70 °C
	protection class	2
	current terminals	< 10 mm <sup>2</sup>
	control terminals	< 2.5 mm <sup>2</sup>

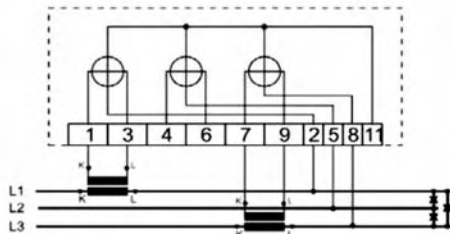


photo is similar to the original

drawing



diagram



# EEH3125

## Three-phase energy transformer meter

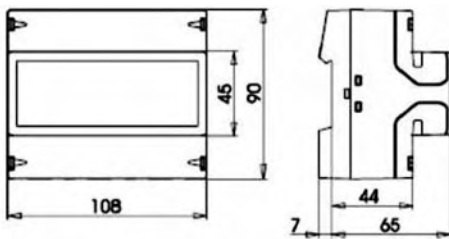
Calibrated AC energy transformer meter for dual tariff for clip-on to 35 mm DIN rail

<b>Type of energy meter</b>	EEH3125xxxx	
	xxxx declaring the primary current is absolutely necessary	
<b>Mains</b>	3-wire	L-L (400 V)
	rated voltage $U_N$	230 V
	tolerance value	-20 %...+15 %
	consumption	< 3.0 W/phase
	frequency	50 Hz
	frequency range	45 ... 65 Hz
<b>Output</b>	1 S0-impulse output	
	optocoupler	40 V / 27 mA max.
(S0)	impulse duration	100 ms +/-50 %
collector open	output impulse	1000 Imp/kWh
	connection terminal	40 / 41 / 42
(option)	communication	
	RS485	EEH3425xxxx
	connection	multi-drop
	cable type	screened, wound pair
	max. cable length	1000 m
	connection	terminal screw
	isolation	3.7 kV rms for 1 min. between all meters and other units
	transmission system	asynchronous
	format type	MODBUS RTU
	transmission time	1200 to 19200 bits/s
	terminal A and B	120 Ohm
	max. linked meters	32
<b>Counter</b>	2 counters for active energy HT-NT (kWh)	
	2 electro-mechanical counters	
	number of digits	7 (6.1 digits)
	digit height	4 mm
	digit width	1.2 mm
	LED test	1000 Imp/kWh (red)
	LED operation	status (tariffs) (red)
(option)	2 counters for active and reactive energy (kWh/kvarh) EEH3225xxxx	
	2 counters for active energy (import/export) (kWh) EEH3245xxxx	
<b>Current range</b>	5 A	
	nominal current $I_N$	5 A
	max. current $I_{max}$	6 A
	consumption	< 0.02 W/current path
	start current	0.002 $I_N$
(option)	nominal current $I_N$	1 A EEH3221xxxx
<b>Primary current</b>	0.5 A to 2000 A	
	If not stated otherwise, the standard version 5 A or 1 A will be supplied.	
<b>Technical data</b>		
	approbations	PTB approval applied for
	active energy	EN 61036 class 1
	reactive energy	EN 61268 class 2
construction	housing	PA6,6 in conformity with UL 94 V-0
	dimensions (mm)	108 x 90 x 72
	weight	0.6 kg
	mounting	DIN rail acc. to DIN EN 50022
	climatic conditions	EN 61036 interior meter
ambient temperature	operation	-20 °C to +55 °C
	storage	-25 °C to +70 °C
	protection class	2
	current terminals	< 10 mm <sup>2</sup>
	control terminals	< 2.5 mm <sup>2</sup>
	tariff start	230 V AC
	Tariff 2 is energized when terminal 13 and 15 are under load of 230 V AC.	

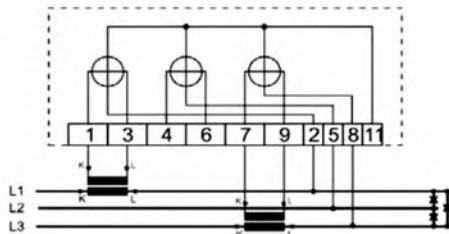


photo is similar to the original

drawing



diagram



# EEH3175

## Three-phase energy transformer meter

Calibrated AC energy transformer meter for dual tariff for clip-on to 35 mm DIN rail

<b>Type of energy meter</b>	EEH3175xxxx
-----------------------------	-------------

xxxx declaring the primary current is absolutely necessary

<b>Mains</b>	3-wire	L-L (400 V)
	rated voltage $U_N$	230 V
	tolerance value	-20 %...+15 %
	consumption	< 3.0 W
	frequency	50 Hz
	frequency range	45 ... 65 Hz

<b>Output</b>	1 S0-impulse output	
	optocoupler	40 V / 27 mA max.
(S0)	impulse duration	100 ms +/-50 %
collector open	output impulse	1000 Imp/kWh
	connection terminal	40 / 41

(option)	communication	RS485	EEH3475xxxx
	connection		multi-drop
	cable type		screened, wound pair
	max. cable length		1000 m
	connection		terminal screw
	isolation		3.7 kV rms for 1 min. between all meters and other units
	transmission system		asynchronous
	format type		MODBUS RTU
	transmission time		1200 to 19200 bits/s
	terminal A and B		120 Ohm
	max. linked meters		32

<b>Counter</b>	LCD counter meter for active energy HT-NT (kWh)	
	number of digits	2 x 9 (8.1 digits)
	digit height	4.86 mm
	digit width	2.96 mm

(option)	2 counters for active and reactive energy (kWh/kvarh)	EEH3285xxxx
	2 counters for active energy (import/export) (kWh)	EEH3295xxxx

<b>Current range</b>	5 A	
	nominal current $I_N$	5 A
	max. current $I_{max}$	6 A
	consumption	< 0.02 W/current path
	start current	0.002 $I_N$

(option)	nominal current $I_N$	1 A	EEH3271xxxx
----------	-----------------------	-----	-------------

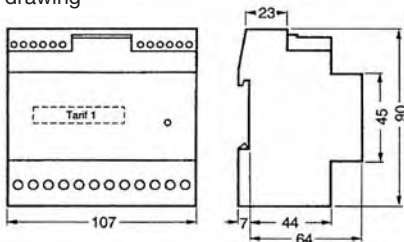
<b>Primary current</b>	0.5 A up to 2000 A
	If not stated otherwise, the standard version 5 A or 1 A will be supplied.

<b>Technical data</b>	approbations	PTB approval applied for EN 61036 class 1
	active energy	EN 61268 class 2
	reactive energy	
construction	housing	PA6.6 in conformity with UL 94 V-0
	dimensions (mm)	108 x 90 x 72
	weight	0.6 kg
	mounting	DIN rail acc. to DIN EN 50022
	climatic conditions	EN 61036 interior meter
ambient temperature	operation	-20 °C to +55 °C
	storage	-25 °C to +70 °C
	protection class	2
	current terminals	< 10 mm <sup>2</sup>
	control terminals	< 2.5 mm <sup>2</sup>
	tariff start	230 V AC
	Tariff 2 is energized when terminal 13 and 15 are under load of 230 V AC.	



photo is similar to the original

drawing



diagram

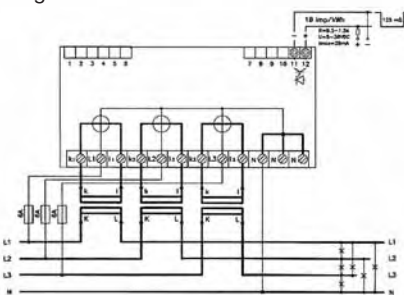


table 1

Encoder Pos.	5 A to	LED imp.-value
5	0.5 A	100 imp/Wh
4	1.0 A	50 imp/Wh
3	2.0 A	25 imp/Wh
2	2.5 A	20 imp/Wh
1	4.0 A	12.5 imp/Wh
0	5.0 A	10 imp/Wh
15	5.0 A	10 imp/Wh
14	10 A	5 imp/Wh
13	20 A	2.5 imp/Wh
12	25 A	2 imp/Wh
11	40 A	1.25 imp/Wh
10	50 A	1 imp/Wh
9	100 A	0.5 imp/Wh
8	125 A	0.4 imp/Wh
7	200 A	0.25 imp/Wh
6	250 A	0.2 imp/Wh

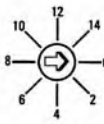
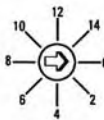


table 2

Encoder Pos.	5 A to	LED imp.-value
5	5 A	10 imp/Wh
4	10 A	5 imp/Wh
3	20 A	2.5 imp/Wh
2	25 A	2 imp/Wh
1	40 A	1.25 imp/Wh
0	50 A	1 imp/Wh
15	50 A	1 imp/Wh
14	100 A	0.5 imp/Wh
13	200 A	0.25 imp/Wh
12	250 A	0.2 imp/Wh
11	400 A	0.125 imp/Wh
10	500 A	0.1 imp/Wh
9	1000 A	0.05 imp/Wh
8	1250 A	0.04 imp/Wh
7	2000 A	0.025 imp/Wh
6	2500 A	0.02 imp/Wh



# EMU4115

## Three-phase energy transformer meter

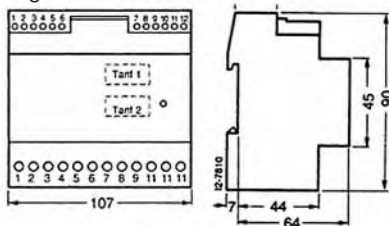
Calibrated AC energy transformer meter for clip-on to 35 mm DIN rail

<b>Type of energy meter</b>	EMU4115xxxx xxxx declaring the primary current is absolutely necessary	
<b>Mains</b>	4-wire rated voltage $U_N$ tolerance value consumption frequency frequency range	L-N (230 V) 230 V -20 %...+20 % 0.8 W/phase 50 Hz 45 ... 65 Hz
<b>Output</b>	1 S0-impulse output optocoupler impulse duration output impulse  impedance connection terminal	5-30 V DC / 20 mA max. approx. 125 ms 10 Imp/kWh 0.5 A to 250 A 1 Imp/kWh 400 A to 2500 A  0.5-1.5 kOhm 11 / 12
<b>Counter</b>	1 counter meter for active energy (kWh) 1 electro-mechanical counter number of digits  digit height digit width LED test LED operation	7 (6.1 digits) 0.5 A up to 250 A 7 (7.0 digits) 400 A up to 2500 A  5 mm 3 mm 10 Imp/Wh (invisible) status (green)
<b>Current range</b>	5 A nominal current $I_N$ max. current $I_{max}$ consumption start current	5 A 6 A 0.8 W/current path 0.002 $I_N$
<b>Primary current</b>	0.5 A up to 2000 A If not stated otherwise, the standard version 5 A will be supplied.	
<b>Technical data</b>	approbations accuracy class dimensions (mm) weight mounting climatic conditions ambient temperature operation storage protection class current terminals control terminals	PTB approval class 1, EN 61036, active energy 107 x 90 x 71 0.35 kg DIN rail acc. to DIN EN 50022-35 EN 61036 interior meter -10 °C to +50 °C -40 °C to +70 °C 2 4.2 x 6.5 mm 2.5 x 3 mm



photo is similar to the original

diagram



drawing

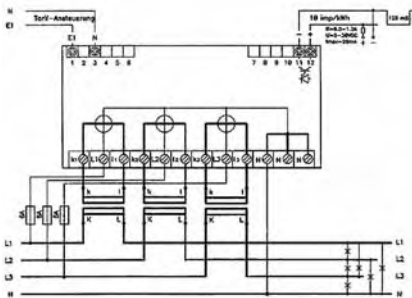


table 1

Current Transformer Table		
Encoder Pos.	5 A to	LED imp.-value
5	0.5 A	100 imp/Wh
4	1.0 A	50 imp/Wh
3	2.0 A	25 imp/Wh
2	2.5 A	20 imp/Wh
1	4.0 A	12.5 imp/Wh
0	5.0 A	10 imp/Wh
15	5.0 A	10 imp/Wh
14	10 A	5 imp/Wh
13	20 A	2.5 imp/Wh
12	25 A	2 imp/Wh
11	40 A	1.25 imp/Wh
10	50 A	1 imp/Wh
9	100 A	0.5 imp/Wh
8	125 A	0.4 imp/Wh
7	200 A	0.25 imp/Wh
6	250 A	0.2 imp/Wh

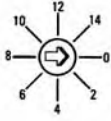
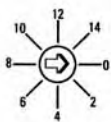


table 2

Current Transformer Table		
Encoder Pos.	5 A to	LED imp.-value
5	5 A	10 imp/Wh
4	10 A	5 imp/Wh
3	20 A	2.5 imp/Wh
2	25 A	2 imp/Wh
1	40 A	1.25 imp/Wh
0	50 A	1 imp/Wh
15	50 A	1 imp/Wh
14	100 A	0.5 imp/Wh
13	200 A	0.25 imp/Wh
12	250 A	0.2 imp/Wh
11	400 A	0.125 imp/Wh
10	500 A	0.1 imp/Wh
9	1000 A	0.05 imp/Wh
8	1250 A	0.04 imp/Wh
7	2000 A	0.025 imp/Wh
6	2500 A	0.02 imp/Wh



# EMU4125

## Three-phase energy transformer meter

Calibrated AC energy transformer meter for dual tariff for clip-on to 35 mm DIN rail

**Type of energy meter** EMU4125xxxx  
xxxx declaring the primary current is absolutely necessary

**Mains** 4-wire L-N (230 V)  
rated voltage  $U_N$  230 V  
tolerance value -20 %...+20 %  
consumption 0.8 W/phase  
frequency 50 Hz  
frequency range 45 ... 65 Hz

**Output** 1 S0-impulse output  
optocoupler 5-30 V DC / 20 mA max.  
impulse duration approx. 125 ms  
(S0) collector open output impulse 10 Imp/kWh 0.5 A up to 250 A  
1 Imp/kWh 400 A up to 2500 A  
impedance 0.5 – 1.5 kOhm  
connection terminal 11 / 12

**Counter** 2 counters for active energy HT-NT (kWh)  
2 electro-mechanical meters  
number of digits 7 (6.1 digits) 0.5 A up to 250 A  
number of digits 7 (7.0 digits) 400 A up to 2500 A  
digit height 4 mm  
digit width 1.2 mm  
LED test 10 Imp/Wh (invisible)  
LED operations status (tariffs) (green)

**Current range** 5 A  
nominal current  $I_N$  5 A  
max. current  $I_{max}$  6 A  
consumption 0.8 W/current path  
start current 0.002  $I_N$

**Primary current** 0.5 A up to 2000 A  
If not stated otherwise, the standard version 5 A will be supplied.

**Technical data**  
approbations PTB approval  
accuracy class class 1, EN 61036, active energy  
dimensions (mm) 107 x 90 x 71  
weight 0.35 kg  
mounting DIN rail acc. to DIN EN 50022-35  
climatic conditions EN 61036 interior meter  
ambient temperature operation -10 °C to +50 °C  
storage -40 °C to +70 °C  
protection class 2  
current terminals 4.2 x 6.5 mm  
control terminals 2.5 x 3 mm  
tariff start 230 V AC  
Tariff 2 is energized when terminals 1 and 3 are under load of 230 V AC.

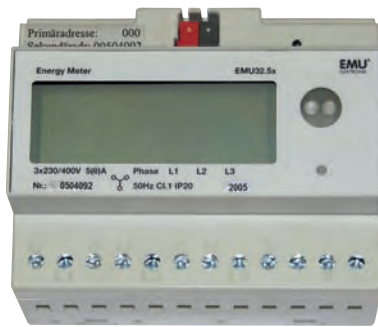
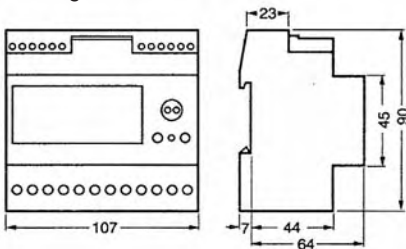
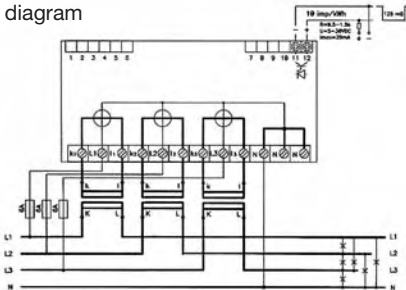


photo is similar to the original

drawing



diagram



# EMU4155

## Three-phase energy transformer meter

Calibrated AC energy transformer meter for clip-on to 35 mm DIN rail

### Type of energy meter EMU4155

Mains	4-wire	L-N (230 V)
rated voltage $U_N$		230 V
tolerance value		-20 %...+20 %
consumption		0.8 W/phase
frequency		50 Hz
frequency range		45 ... 65 Hz

### Output 1 S0-impulse output

(S0) optocoupler		5-30 V DC / 20 mA max.
collector open impulse duration		approx. 20 ms
output impulse		1000 Imp/kWh
impedance		0.5 – 1.5 kOhm
connection terminal		11 / 12

### Counter LCD-counter meter for active energy (kWh)

LCD display		rolling counter
counter indication kWh for T1		display duration 15 s
		number of digits 7 (6.1 digits)
		digit height 8 mm
		digit width 4.5 mm
unit no.		display duration 2 s
		customer specific data can be programmed at works
software version		display duration 2 s
segment test		display duration 2 s
energy flow		supply stopped two-way flow
operating display		3 arrows at lower end of LCD
LED test		10 Imp/Wh (invisible)

### Current range 5 A

nominal current $I_N$		5 A
max. current $I_{max}$		6 A
consumption		0.8 W/current path
start current		0.002 $I_N$

### Technical data

approbations		PTB approval applied for active energy
accuracy class		class 1, EN 61036
dimensions (mm)		107 x 90 x 71
weight		0.35 kg
mounting		DIN rail acc. to DIN EN 50022-35
climatic conditions		EN 61036 interior meter
operation		-10 °C to +50 °C
storage		-40 °C to +70 °C
protection class		2
current terminals		4.2 x 6.5 mm
control terminals		2.5 x 3 mm
interface		optical interface acc. to IEC 61107

ambient temperature

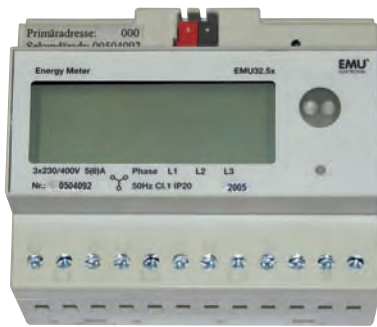
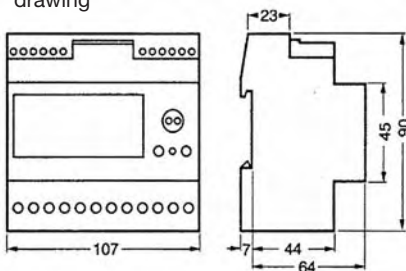
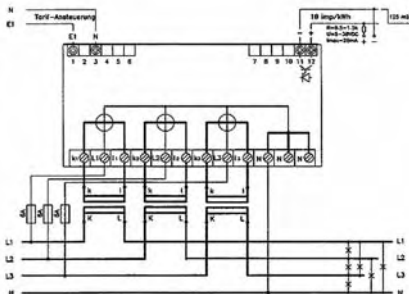


photo is similar to the original

drawing



diagram



# EMU4175

## Three-phase energy transformer meter

Calibrated AC energy transformer meter for dual tariff for clip-on to 35 mm DIN rail

**Type of energy meter** EMU4175

<b>Mains</b>	4-wire	L-N (230 V)
	rated voltage $U_N$	230 V
	tolerance value	-20 %...+20 %
	consumption	0.8 W/phase
	frequency	50 Hz
	frequency range	45 ... 65 Hz

<b>Output</b>	1 S0-impulse output	5-30 V DC / 20 mA max.
(S0)	optocoupler	
collector open	impulse duration	approx. 20 ms
	output impulse	1000 Imp/kWh
	impedance	0.5-1.5 kOhm
	connection terminal	11 / 12

<b>Counter</b>	LCD counter meter for active energy HT-NT (kWh)	
	LCD display	rolling counter
	counter indication kWh for T1	display duration 15 s
		number of digits 7 (6.1 digits)
		digit height 8 mm
		digit width 4.5 mm
	counter indication kWh for T2	display duration 15 s
	unit no.	display duration 2 s
		customer specific data can be programmed at works
	software version	display duration 2 s
	segment test	display duration 2 s
	energy flow	supply stopped two-way flow
	operating display	3 arrows at lower end of LCD
	LED test	10 Imp/Wh (invisible)

<b>Current range</b>	5 A
	nominal current $I_N$ 5 A
	max. current $I_{max}$ 6 A
	consumption 0.8 W/current path
	start current 0.002 $I_N$

<b>Technical data</b>	approbations	PTB approval applied for active energy
	accuracy class	class 1, EN 61036
	dimensions (mm)	107 x 90 x 71
	weight	0.35 kg
	mounting	DIN rail acc. to DIN EN 50022-35
	climatic conditions	EN 61036 interior meter
	operation	-10 °C to +50 °C
	storage	-40 °C to +70 °C
	protection class	2
	current terminals	4.2 x 6.5 mm
	control terminals	2.5 x 3 mm
	interface	optical interface
		acc. to IEC 61107
	tariff start	230 V AC
	Tariff 2 is energized when terminals 1 and 3 are under load of 230 V AC.	

ambient temperature

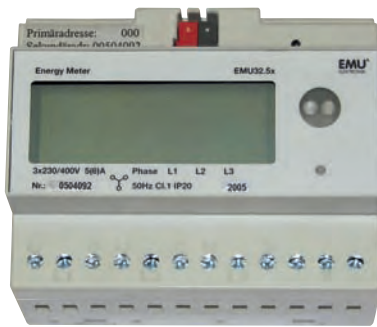
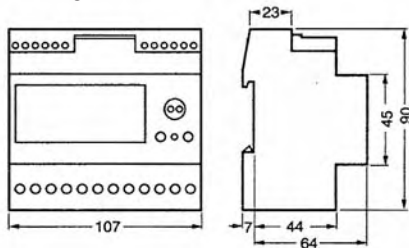
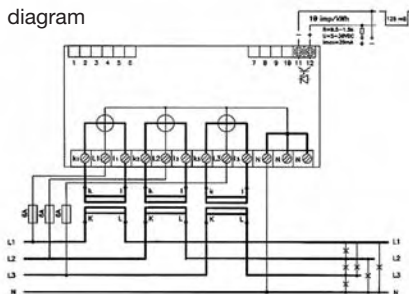


photo is similar to the original

drawing



diagram



# EMU4755

## Three-phase energy transformer meter M-BUS

Calibrated AC energy transformer meter for clip-on to 35 mm DIN rail

<b>Type of energy meter</b>		EMU4755
<b>Mains</b>		4-wire L-N (230 V) rated voltage $U_N$ 230 V tolerance value -20 %...+20 % consumption 0.8 VA frequency 50 Hz frequency range 45 ... 65 Hz
<b>Output</b>		1 impulse output and M-BUS output optocoupler 5-30 V DC / 20 mA max. impulse duration ca. 20 ms collector open output impulse 1000 Imp/kWh impedance 0.5 – 1.5 kOhm connection terminal 11 / 12 M-BUS data selection current system time of the meter operation hours of the meter total active energy actual active power number of voltage interruptions error flag/time indication of the last power cut
<b>Counter</b>		LCD counter meter for active energy (kWh) LCD display rolling counter counter indication kWh for T1 display duration 15 s number of digits 7 (6.1 digits) digit height 8 mm digit width 4.5 mm display duration 2 s unit no. customer specific data can be programmed at works software version display duration 2 s segment test display duration 2 s energy flow supply stopped two-way flow operating display 3 arrows at lower end of LCD LED test 10 Imp/Wh (invisible)
<b>Current range</b>		5 A nominal current $I_N$ 5 A max. current $I_{max}$ 6 A consumption 0.8 W/current path start current 0.002 $I_N$
<b>Technical data</b>		approbations PTB approval applied for active energy accuracy class class 1, EN 61036 dimensions (mm) 107 x 90 x 71 weight 0.35 kg mounting DIN rail acc. to DIN EN 50022-35 climatic conditions EN 61036 interior meter ambient operation -10 °C to +50 °C temperature storage -40 °C to +70 °C protection class 2 current terminals 4.2 x 6.5 mm control terminals 2.5 x 3 mm interface optical interface acc. to IEC 61107

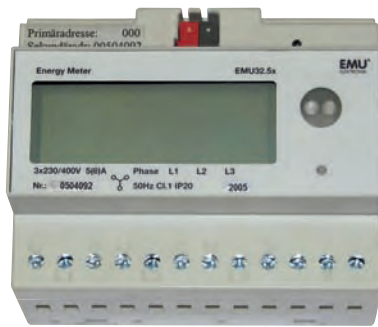
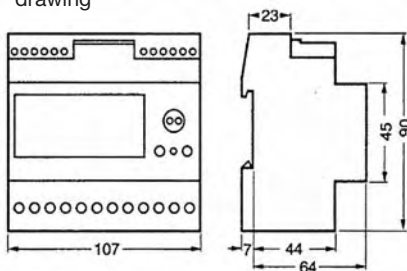
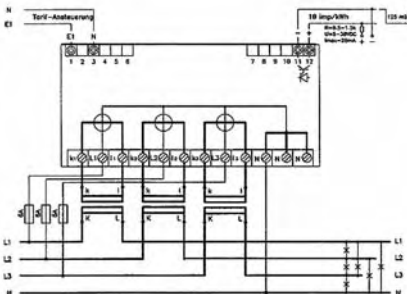


photo is similar to the original

drawing



diagram



# EMU4775

## Three-phase energy transformer meter M-BUS

Calibrated AC energy transformer meter for dual tariff for clip-on to 35 mm DIN rail

**Type of energy meter** EMU4775

<b>Mains</b>	4-wire	L-N (230 V)
	rated voltage $U_N$	230 V
	tolerance value	-20 %...+20 %
	consumption	0.8 W/phase
	frequency	50 Hz
	frequency range	45 ... 65 Hz

**Output** 1 impulse output and M-BUS output

(S0) collector open	optocoupler	5-30 V DC / 20 mA max.
	impulse duration	approx. 20 ms
	output impulse	1000 Imp/kWh
	impedance	0.5 – 1.5 kOhm
	connection terminal	11 / 12
	M-BUS data selection	current system time of the meter operation hours of the meter total active energy actual active power number of voltage interruptions error flags/time indication of the last power cut

**Counter** LCD counter meter for active energy HT-NT (kWh)

LCD display	rolling counter	
counter indication kWh for T1	display duration	15 s
	number of digits	7 (6.1 digits)
	digit height	8 mm
	digit width	4.5 mm
counter indication kWh for T2	display duration	15 s
unit no.	display duration	2 s
	customer specific data can be programmed at works	
software version	display duration	2 s
segment test	display duration	2 s
energy flow	supply stopped two-way flow	
operating display	3 arrows at lower end of LCD	
LED test	10 Imp/Wh	(invisible)

**Current range** 5 A

nominal current $I_N$	5 A
max. current $I_{max}$	6 A
consumption	0.8 W/current path
start current	0.002 $I_N$

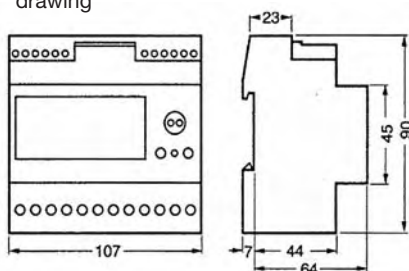
**Technical data**

approbations	PTB approval applied for active energy
accuracy class	class 1, EN 61036
dimensions (mm)	107 x 90 x 71
weight	0.35 kg
mounting	DIN rail acc. to DIN EN 50022-35
climatic conditions	EN 61036 interior meter
operation	-10 °C to +50 °C
storage	-40 °C to +70 °C
protection class	2
current terminals	4.2 x 6.5 mm
control terminals	2.5 x 3 mm
interface	optical interface acc. to IEC 61107
tariff start	230 V AC
	Tariff is energized when terminals 1 and 3 are under load of 230 V AC.

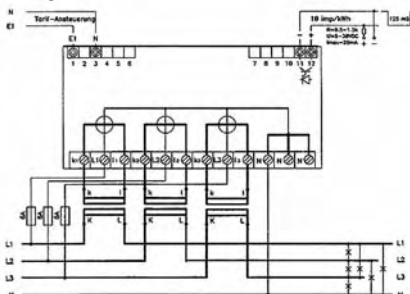


photo is similar to the original

drawing



diagram



# EMU4165

## Three-phase energy transformer meter

Calibrated AC energy transformer meter for dual tariff for clip-on to 35 mm DIN rail

<b>Type of energy meter</b>		EMU4165xxxx
		xxxx declaring the primary current is absolutely necessary
<b>Mains</b>		4-wire
	rated voltage $U_N$	L-N (230 V)
	tolerance value	230 V
	consumption	-20 %...+20 %
	frequency	0.8 W/phase
	frequency range	50 Hz
		45 ... 65 Hz
<b>Output</b>		1 S0-impulse output
(S0)	optocoupler	5-30 V DC / 20 mA max.
collector open	impulse duration	approx. 125 ms
	output impulse	10 Imp/kWh
	impedance	0.5 – 1.5 kOhm
	connection terminal	11 / 12
<b>Counter</b>		LCD counter meter for active energy/active power HT-NT (kWh)
	LCD display	counter (push black button to operate)
	active energy (T1)	kWh, price/kWh, total price
		7 (6.1) digits 4.5 x 8 mm
	active energy (T2)	kWh, price/kWh total price
	present active power	kW total, kW L1-L2-L3
	present voltage	V L1-L2-L3
	present current	A total, A L1-L2-L3
	current transformer factor	FA e.g. 100A, FA 20 (100/5)
	unit no.	5 digits
	LED test	10 Imp/Wh (invisible)
<b>Current range</b>		5 A
	nominal current $I_N$	5 A
	max. current $I_{max}$	6 A
	consumption	0.8 W/current path
	start current	0.002 $I_N$
<b>Primary current</b>		5 A up to 1275 A
		If not stated otherwise, the standard version of 5 A will be supplied.
<b>Technical data</b>		
	approbations	PTB approval
	accuracy class	class 1, EN 61036, active energy
	dimensions (mm)	107 x 90 x 71
	weight	0.35 kg
	mounting	DIN rail acc. to DIN EN 50022-35
	climatic conditions	EN 61036 interior meter
ambient temperature	operation	-10 °C to +50 °C
	storage	-40 °C to +70 °C
	protection class	2
	current terminals	4.2 x 6.5 mm
	control terminals	2.5 x 3 mm
	interface	optical interface
		acc. to IEC 61107
	tariff start	230 V AC
		Tariff 2 is energized when terminals 1 and 3 are under load of 230 V AC.

## Electro-mechanical energy meter for tariff applications

### Single-phase energy meter, direct measuring

EMZ70110040	2-wire	230 V		kWh	10 (40) A
EMZ70110060	2-wire	230 V		kWh	10 (60) A

### Three-phase energy meter, direct measuring

EMZ40110040	4-wire	3x230/400 V		kWh	10 (40) A
EMZ40210040	4-wire	3x230/400 V	2 tariffs, HT-NT	kWh	10 (40) A
EMZ40115060	4-wire	3x230/400 V		kWh	15 (60) A
EMZ40215060	4-wire	3x230/400 V	2 tariffs, HT-NT	kWh	15 (60) A
EMZ40110060	4-wire	3x230/400 V		kWh	10 (60) A
EMZ40210060	4-wire	3x230/400 V	2 tariffs, HT-NT	kWh	10 (60) A

### Electronic three-phase energy meter, direct measuring for three point counter mounting

EMZ40120100	4-wire	3x230/400 V		kWh	20 (100) A
EMZ40125100	4-wire	3x230/400 V		kWh	25 (100) A

### Three-phase energy transformer meter

EMZ4015	4-wire	3x230/400 V		kWh	5 A
EMZ4025	4-wire	3x230/400 V	2 tariffs, HT-NT	kWh	5 A



## Code

Code	article no.										
Code	E	X	X	*	*	*	*	X	X	X	X
<b>Type of energy meter</b>											
AAD1D5F	E	A	A								
ECP***	E	C	P								
EM1000	E	E	M								
EMU****	E	M	U								
EMU****	E	M	U								
EEH****	E	E	H								
EMU****	E	M	U								
WS****	E	W	S								
WQ****	E	W	Q								
Electro mechanical meter	E	M	Z								
<b>Mains</b>											
4-wire											1
3-wire											2
4-wire (calibrated)											4
3-wire (calibrated)											3
4-wire (equally loaded phases)											5
2-wire											6
2-wire (calibrated)											7
3-wire (equally loaded phases)											8
special configurations upon request											9
<b>Output</b>											
without S0-Impulse output											0
1 S0-impulse output											1
2 S0-impulse outputs											2
1 impulse output and RS485 output											3
2 S0-impulse outputs and RS485 output											4
cable connection											5
socket											6
1 impulse output and M-BUS output											7
1 relay impulse output (only for EWS****, EWQ****)											9
<b>Counter</b>											
1 counter for reactive energy (kvarh)											0
1 counter for active energy (kWh)											1
2 counters for active energy HT-NT (kWh)											2
2 counters for active and reactive energy (kWh)/(kvarh)											3
2 counters for active energy import/export (kWh)											4
LCD counter for active energy (kWh)											5
LCD counter for active energy/active power HT-NT (kWh)/(kW)											6
LCD counter for active energy HT-NT (kWh)											7
LCD counter for active and reactive energy (kWh)/(kvarh)											8
LCD counter for active energy import/export (kWh)											9
<b>Current range</b>											
1 A											1
5 (32) A											2
26 (30) A											3
5 (63) A											4
5 A											5
10 (30) A								1	0	0	3
10 (40) A								1	0	0	4
15 (60) A								1	5	0	6
10 (60) A								1	0	0	6
10 (100) A								1	0	1	0
10 (63) A								6			
16 A								7			
<b>Primary current (only for current transformer meters)</b>											
<b>Example: Secondary 1 A, primary 125 A</b>									x	x	x
									1	0	1
										2	5



## 10 reasons to be associated with products from MBS

- ✓ customer oriented solutions
- ✓ individual consultancy
- ✓ satisfied customers in all continents
- ✓ a product range in excess of 20000 units
- ✓ supreme technical quality
- ✓ a multiple of international licences and certificates,  
DIN EN ISO 9001-2000
- ✓ official calibration of current transformers and measuring units
- ✓ reliability
- ✓ fast deliveries
- ✓ 30 years of success



**MBS AG**  
(the Company)

**CONDITIONS OF SALE**

**1. INTERPRETATION**

1.1 In these Conditions:

**Customer** means the person who accepts a quotation of the Company for the sale of the goods or whose order for the Goods is accepted by the Company

**Goods** means the goods (including any instalment of the goods or any parts for them) which the Company is to supply in accordance with these Conditions

**Conditions** means the standard terms and conditions of sale set out in this document and (unless the context otherwise requires) includes any special terms and conditions agreed in writing between the Customer and the Company

**Contract** means the contract for the purchase and sale of the Goods

**Incoterms** means the international rules for the interpretation of trade terms of the International Chamber of Commerce as in force at the date when the Contract is made. Unless the context otherwise requires, any term or expression which is defined in or given a particular meaning by the provisions of Incoterms shall have the same meaning in these Conditions, but if there is any conflict between the provisions of Incoterms and these Conditions, the latter shall prevail.

**Writing** includes facsimile transmission, e-mail and comparable means of communication

**Export** means for transport outside the Federal Republic of Germany

- 1.2 A reference to a particular legal concept includes any analogous act or concept in any part of the world where the context so admits and if rights of the Company as provided in these Conditions cannot be validly exercised or retained in another jurisdiction, provided that the laws of such other jurisdiction are applicable, then the Customer shall fully cooperate with the Company and shall do or omit to do any acts or things or execute such documents or deeds as may be required by the Company to give effect to those rights of the Company.
- 1.3 A reference to a particular law is a reference to it as it is in force for the time being.
- 1.4 Words in the singular include the plural and in the plural include the singular.
- 1.5 A reference to one gender includes a reference to the other gender.
- 1.6 Condition headings do not affect the interpretation of these conditions.

**2. BASIS OF THE SALE**

- 2.1 The Company sells and the Customer purchases the Goods in accordance with any written quotation of the Company which is accepted by the Customer, or any written order of the Customer which is accepted in writing by the Company, subject in either case to these Conditions, which govern the Contract to the exclusion of any other terms and conditions subject to which any quotation is accepted or purported to be accepted, or any order is made or purported to be made, by the Customer. Written confirmation of any verbal order or quotation shall be deemed as the Company's written quotation or written acceptance of order as appropriate.
- 2.2 No variation of these Conditions is binding on the Company unless agreed in writing between the authorised representatives of the Customer and the Company. The Company's employees or agents are not authorised to make any representations about the Goods or the Contract unless confirmed by the Company in Writing. In entering into the Contract the Customer acknowledges that it does not rely on, and waives any claim for breach of, any representations which are not so confirmed.
- 2.3 Any typographical, clerical or other error or omission in any sales literature, quotation, price list, acceptance of offer, invoice or other document or information issued by the Company may be corrected without any liability on the Company.
- 2.4 All samples, drawings, descriptive matter, specifications and advertising issued by the Company and any descriptions or illustrations contained in the Company's catalogues or brochures are issued or published only to give an approximate idea of the Goods described in them. They shall not form part of the Contract and this is not a sale by sample.
- 2.5 The Customer confirms that provision of any personal data (as defined in the Data Protection Act 1998 – "the Act") is in accordance with the

Act and that the Customer gives all consents necessary in order for the Company to lawfully process such data and to pass the data to third parties for the proper business purposes of the Company, and in each case the data may pass outside the European Economic Area.

**3. ORDERS AND SPECIFICATIONS**

- 3.1 The Customer is responsible to the Company for ensuring the completeness and accuracy of the terms of any order or request for quotation and any other information submitted by the Customer, within a sufficient time for the Company to perform the Contract in accordance with its terms.
- 3.2 The Goods are designed and manufactured in accordance with the legal requirements of the Federal Republic of Germany. Any variations from these requirements requested by the Customer are at the cost and risk of the Customer who shall indemnify the Company for any actual or potential liability arising in consequence plus associated costs. If the Goods are to be manufactured or processed in accordance with a specification of the Customer, the Customer shall indemnify the Company against all liability of the Company for loss, damages, costs and expenses any claim for infringement of any industrial or intellectual property rights of any other person which results from the Company's use of the Customer's specification and any claim against the Company in respect of any alleged defect in the Goods.
- 3.3 The Company reserves the right to change the specification of the Goods to conform with any applicable safety or other statutory or EU requirements or, where the Goods are to be supplied to the Customer's specification, which do not materially affect their quality or performance.
- 3.4 No order which has been accepted by the Company or quotation accepted by the Customer may be amended or cancelled by the Customer except with the agreement of the Company and on terms that the Customer fully indemnifies the Company against all loss costs, damages, charges and expenses incurred by the Company as a result of the amendment or cancellation.
- 3.5 Samples may be provided at the discretion of the Company free of charge for a period of four weeks from delivery of the sample to the Customer, subject to return in good condition. Any postal or freight charges for the delivery or return of samples shall be at the cost of the Customer. A charge will be made for late return or non return of samples or damage to samples.
- 3.6 The Company shall retain the exclusive intellectual property rights in any original works or inventions, intellectual property created by or on behalf of the Company in respect of any order, quotation or Contract and it shall be a condition of any supply or production of the same to the Customer that details of such the same are kept strictly confidential.

**4. PRICE OF THE GOODS**

- 4.1 The price of the Goods shall be the price listed in the Company's published price list current at the date of delivery or deemed delivery subject to variation as set out below. Unless otherwise specified by the Company all quotations are valid for eight weeks.
- 4.2 The Company may, by giving notice to the Customer at any time before delivery, increase the price of the Goods to reflect any increase in cost to the Company which is due to any factor beyond its reasonable control, any change in delivery dates, quantities or specifications for the Goods which is requested by the Customer, or any delay caused by any instructions of the Customer or failure of the Customer to give the Company adequate information or instructions. In particular but without limitation the Company may vary prices to reflect increases in the price of raw materials (including metals trading on the London Metal Exchange ("LME")), energy costs and climate change levies, provided always that (except in the case of the daily LME copper price) if the increase is in excess of 10 % above the original quoted price the Customer may by notice request the alteration or cancellation of the Contract by notifying the Company of the same [by return] upon receipt of notice of the relevant price increase. The Company reserves the right to withdraw from any tender or cancel any Contract in case of failure to agree any price change.

- 4.3 Except as otherwise stated in any quotation or price list of the Company or agreed in writing between the Customer and the Company, all prices given by the Company are on an ex-works basis. If delivery is otherwise than at the Company's premises, the Customer will be charged additionally for transport, packaging and insurance on orders below the minimum order value as specified by the Company from time to time, in the case of deliveries in Germany.
- 4.4 Export orders not less than the minimum order value specified by the Company will be made FCA Incoterms to German sea port or airport or German border. The Company shall be under no obligation to give notice under Section 32(3) of the Sale of Goods Act 1979.
- 4.5 All prices and other charges are quoted in euros exclusive of VAT or other applicable excise duty or sales tax, costs of packaging and customs clearance, which is payable in addition. The Customer shall provide all identification, VAT, or other information reasonably required by the Company and the Company may claim reimbursement from the Customer for any liability to tax, levy or other charges and costs due to any omission or error of such information. Any certification by government authorities or otherwise required shall be charged to the Customer at cost. The Customer shall be responsible for arranging for any testing and inspection of the Goods at the Company's premises before placing his order.
- 4.6 Calibration charges as provided under the respective current Eichgebuhenverordnung regulation on calibration charges of the Physikalisch Technische Bundesanstalt ("PTB" or National Institute of Natural and Engineering Sciences) at Braunschweig shall apply to tariff current transformers. These charges shall apply in addition to the sales price and shall not be trade discountable or cash discountable.
- 5. TERMS OF PAYMENT**
- 5.1 The Company may invoice the Customer for the price of the Goods on or at any time after delivery of the Goods, unless the Goods are to be called off in instalments as required or collected by the Customer or the Customer wrongfully fails to take delivery of the Goods in which event the Company may invoice the Customer for the price at any time after the Goods are ready for calling off or collection or (as the case may be) the Company has tendered delivery of the Goods.
- 5.2 Payment is due in euros (without deduction whether by way of set off counterclaim, discount, abatement or otherwise) within 30 days of the Company's invoice, notwithstanding that delivery may not have taken place and title to the Goods has not passed to the Customer. The time of payment of the price is of the essence of the Contract. Upon termination of the Contract all payments to the Company will immediately become due.
- 5.3 If the Customer fails to make any payment on the due date (or commits any other breach of the Contract) then, without prejudice to any other right or remedy available to the Company, the Company may:
- 5.3.1 cancel the Contract or suspend any further deliveries to the Customer under the Contract or any other Contracts with the Customer;
- 5.3.2 appropriate any payment made by the Customer to such of the Goods (or the goods supplied under any other contract between the Customer and the Company) as the Company thinks fit; and
- 5.3.3 charge the Customer interest (both before and after any judgement) on the amount unpaid, at the rate of 8% p.a. above European Central Bank base rate from time to time accruing daily until payment in full is made;
- 5.3.4 disapply any agreed discount in which case the payment due shall be increased accordingly.
- 5.4 No payment shall be deemed received until the Company has received cleared funds.
- 6. DELIVERY**
- 6.1 Delivery of the Goods shall be made on an Ex Works basis. Assistance with loading Goods at the Company's premises will be provided free of charge at the Company's discretion and at the Customer's risk.
- 6.2 Any dates quoted for delivery of the Goods are approximate only and the Company shall not be liable for any delay in delivery of the Goods howsoever caused. Time for delivery shall not be of the essence unless previously agreed by the Company in writing. The Goods may be delivered before the quoted delivery date on giving reasonable notice to the Customer.
- 6.3 No partial deliveries are permitted but the Company may at its discretion deliver the Goods by separate instalments, in which case each delivery shall constitute a separate contract. Failure by the Company to deliver any one or more of the instalments in accordance with those Conditions or any claim by the Customer in respect of any one or more instalments shall not entitle the Customer to cancel or treat the Contract as a whole as repudiated.
- 6.4 If the Customer fails to take delivery or call off the Goods within the time agreed or fails to give the Company adequate delivery instructions or requisite documents or authorisations for delivery (otherwise than due to any cause beyond the Customer's reasonable control or the Company's fault) then, without prejudice to any other right or remedy available to the Company:
- 6.4.1 the Goods shall be deemed delivered and risk shall pass to the Customer (including for loss or damage caused by the Company's negligence); and
- 6.4.2 the Company may store the Goods until actual delivery without liability at the cost and risk of the Customer and charge the Customer for the reasonable costs (including insurance) of storage or sell the Goods at the best price readily obtainable and (after deducting all reasonable storage and selling expenses) account to the Customer for the excess over the price under the Contract or charge the Customer for any shortfall below the price under the Contract.
- 6.5 Claims for damage in transit, short delivery or non-delivery or loss in transit must be made in writing to the Company [and carrier] within seven days of the actual or anticipated date of delivery whichever is the earlier. Any additional information must be provided at the request of the Company and the expense of the Customer.
- 6.6 The Customer shall not be entitled to object to or reject the Goods or part of the Goods by reason of delivery of a surplus or shortfall of up to 10% of the quantity stated in the Contract and shall pay for such Goods at the pro rata Contract rate.
- 6.7 Any liability of the Company for non-delivery of the Goods shall be limited to replacing the Goods within a reasonable time or issuing a credit note at the pro rata Contract rate against any invoice raised for such Goods.
- 7. OWNERSHIP OF GOODS**
- 7.1 Notwithstanding delivery and passing of risk in the Goods or any other provision of these Conditions, ownership of the Goods shall not pass to the Customer until the Company has received in full (in cash or cleared funds) all sums due to it in respect of:
- 7.1.1 the Goods; and
- 7.1.2 all other sums which are or which become due to the Company from the Customer on any account.
- 7.2 Without prejudice to any common law or statutory rights of the Company as unpaid seller, until ownership of the Goods has passed to the Customer, the Customer shall:
- 7.2.1 hold the Goods on a fiduciary basis as the Company's bailee;
- 7.2.2 store the Goods (at no cost to the Company) separately from all other goods of the Customer or any third party in such a way that they remain readily identifiable as the Company's property;
- 7.2.3 not destroy, deface or obscure any identifying mark or packaging on or relating to the Goods; and
- 7.2.4 maintain the Goods in satisfactory condition and keep them insured on the Company's behalf for their full price plus 10% against all risks to the reasonable satisfaction of the Company. On request the Customer shall produce the policy of insurance to the Company.
- 7.3 The Customer may resell the Goods before ownership has passed to it solely on the following conditions:
- 7.3.1 any sale shall be effected in the ordinary course of the Customer's business at full market value; and
- 7.3.2 any such sale shall be a sale of the Company's property on the Customer's own behalf and the Customer shall deal as principal when making such a sale.

- 7.4 Until such time as the title in the Goods passes to the Customer (and provided the Goods are still in existence and have not been resold), the Company shall be entitled at any time to require the Customer to deliver up the Goods to the Company and, if the Customer fails to do so forthwith, the Customer grants the Company its agents and employees an irrevocable licence to enter at any time any vehicles or premises owned or occupied by the Customer or in its possession or control to inspect, repossess and remove the Goods. The Customer will indemnify the Company against any liability for damages caused in such repossession which could not reasonably have been avoided.
- 7.5 The Customer's right to possession of the Goods shall terminate immediately if:
- 7.5.1 the Customer has a bankruptcy order made against him or makes an arrangement or composition with his creditors, or otherwise takes the benefit of any statutory provision for the time being in force for the relief of insolvent debtors, or (being a body corporate) convenes a meeting of creditors (whether formal or informal), or enters into liquidation (whether voluntary or compulsory) except a solvent voluntary liquidation for the purpose only of reconstruction or amalgamation, or has a receiver and/or manager, administrator or administrative receiver appointed of its undertaking or any part thereof, or documents are filed with the court for the appointment of an administrator of the Customer or notice of intention to appoint an administrator is given by the Customer or its directors or by a qualifying floating charge holder (as defined in paragraph 14 of Schedule B1 to the Insolvency Act 1986), or a resolution is passed or a petition presented to any court for the winding-up of the Customer or for the granting of an administration order in respect of the Customer, or any proceedings are commenced relating to the insolvency or possible insolvency of the Customer; or
- 7.5.2 the Customer suffers or allows any execution, whether legal or equitable, to be levied on his/its property or obtained against him/it, or fails to observe or perform any of his/its obligations under the Contract or any other contract between the Company and the Customer, or is unable to pay its debts within the meaning of section 123 of the Insolvency Act 1986 or the Customer ceases to trade; or
- 7.5.3 the Customer encumbers or in any way charges any of the Goods.
- 7.6 The Customer may not pledge or in any way charge by way of security for any indebtedness any of the Goods which remain the property of the Company, but if the Customer does so (or does or fails to do anything and the provisions of Clause 7.5.1 or 7.5.2. may or do apply), all sums owing by the Customer to the Company shall (without prejudice to any other right or remedy of the Company) immediately be due and payable.
- 7.7 The Company shall be entitled to recover payment for the Goods notwithstanding that ownership of any of the Goods has not passed from the Company.
- 7.8 Where the Company is unable to determine whether any Goods are the goods in respect of which the Customer's right to possession has terminated, the Customer shall be deemed to have sold all goods of the kind sold by the Company to the Customer in the order in which they were invoiced to the Customer.
- 7.9 If any of the events mentioned in Clause 7.5 above shall occur or the Company reasonably apprehends that any of those events is about to occur in relation to the Customer and notifies the Customer accordingly, then, without prejudice to any other right or remedy available to the Company, the Company may cancel the Contract or suspend any further deliveries under the Contract without any liability to the Customer, and if the Goods have been delivered but not paid for the price shall become immediately due and payable notwithstanding any previous agreement or arrangement to the contrary.
- 7.10 On termination of the Contract, howsoever caused, the Company's (but not the Customer's) rights contained in this condition 7 shall remain in effect.

## 8. WARRANTIES

- 8.1 Subject to the conditions set out below the Company warrants that the Goods will be free from defects in material and workmanship for a period of 1 year from delivery.

- 8.2 This warranty is given subject to the following conditions:

- 8.2.1 the Company is not liable for any defect in the Goods arising from any drawing, design or specification supplied by the Customer or for any defect arising from fair wear and tear, wilful damage, negligence, abnormal working conditions, failure to follow the Company's instructions oral or in writing, misuse or alteration or repair of the Goods without the Company's approval;
- 8.2.2 no warranty is given as to the length of working life of the Goods or that they will be suitable for any specific purpose or conditions, notwithstanding that such purpose and conditions have been made known to the Company;
- 8.2.3 the Company is not liable under this warranty (or any other warranty, condition or guarantee) if the total price for the Goods has not been paid by the due date for payment;
- 8.2.4 this warranty does not extend to parts, materials or equipment not manufactured by the Company, in respect of which the Customer is only entitled to the benefit of such warranty or guarantee of the manufacturer to the Company as the Company is able to pass on to the Customer;
- 8.2.5 Defects claims are notified to the Company within [7] days from delivery or (where the defect was not apparent on reasonable inspection) within 14 days after discovery of the defect. If delivery is not refused, and the Customer does not notify the Company within this time, the Customer will be deemed to have accepted the Goods as complying with the Contract and must pay the price for the Goods accordingly;
- 8.2.6 the Company must be given a reasonable opportunity after receiving notice of defect for examining such Goods and the Customer (if asked to do so by the Company) must return such Goods to the Company's place of business at the Customer's cost for the examination to take place there;
- 8.3 Subject to condition 8.2, if any of the Goods do not conform with the warranty in condition 8.1 the Company shall at its option repair or replace such Goods (or the defective part) or refund the price of such Goods at the pro rata Contract rate provided that, if the Company so requests, the Customer shall return the Goods or the part of such Goods which is defective to the Company at their own expense. The Company shall refund the expenses incurred by the customer if the complaint is proven.

## 9. LIMITATION OF LIABILITY

- 9.1 Subject to condition 8 – warranty, the following provisions set out the entire financial liability of the Company (including any liability for the acts or omissions of its employees, agents and sub-contractors) to the Customer in respect of:
- 9.1.1 any breach of these conditions including (without limitation) any delay or failure in the delivery of the Goods;
- 9.1.2 any use made or resale by the Customer of any of the Goods, or of any product incorporating any of the Goods; and
- 9.1.3 any representation, statement or tortious act or omission including negligence arising under or in connection with the Contract.
- 9.2 All warranties, conditions and other terms implied by statute or common law or other analogous laws are, to the fullest extent permitted by law, excluded from the Contract.
- 9.3 Nothing in these conditions excludes or limits the liability of the Company for any matter which it would be illegal for the Company to exclude or attempt to exclude its liability including, if applicable:
- 9.3.1 for death or personal injury caused by the Company's negligence; or
- 9.3.2 under section 2(3), Consumer Protection Act 1987; or
- 9.3.3 for fraud or fraudulent misrepresentation.
- 9.4 Subject to condition 9.2 and condition 9.3:
- 9.4.1 the Company's total liability in contract, tort (including negligence or breach of statutory duty), misrepresentation, restitution or otherwise, arising in connection with the performance or contemplated performance of the Contract shall be limited to the lesser of the value of the Goods supplied under the Contract to which any claim relates; or
- 9.4.2 the amount received by the Company in relation to the Contract under any relevant liability insurance currently held by the Company; [and]

9.4.3 the Company shall not otherwise be liable for any loss (including, without limitation pure economic loss, loss of profit, loss of business, or depletion of goodwill) in each case whether direct, indirect or consequential, or any claims for consequential compensation whatsoever (howsoever caused) cost, damages, charges or expenses which arise directly or indirectly out of or in connection with the Contract.

9.5 The Customer recognises that the limitation of liability contained in this clause is reasonable in that the prices quoted by us are dependent upon such limitation being incorporated in the Contract, and that we may have insurance cover which covers some or all of the losses purported to be excluded herein, but that there are legitimate business reasons for still excluding such liability, including (but not limited to) the maintenance of a clean insurance claims record.

#### 10. FORCE MAJEURE

The Company shall not be liable to the Customer or in breach of the Contract due to any delay in performing, or any failure to perform or any variation in performance of, any of the Company's obligations if the delay or failure was due to any cause beyond the Company's reasonable control. [Provided that if the event in question continues for a continuous period in excess of [one hundred and eighty (180) days, the Customer shall be entitled to give notice in writing to the Company to terminate the Contract].

#### 11. ADDITIONAL EXPORT TERMS

11.1 Unless otherwise agreed in writing by the Company, all Goods are supplied on the strict condition that:

- 11.1.1 they are solely for civil use;
- 11.1.2 they are not to be supplied to any country or for any application prohibited by any law or regulation binding or effective in the European Union and United States;
- 11.1.3 they will not in any way be installed used or applied in or in connection with the operation of any nuclear facilities such as but not limited to nuclear power plants, nuclear fuel manufacturing plants, uranium enrichment plants, spent nuclear fuel stores or research reactors.

11.2 The Customer undertakes not to offer the Goods for resale in any country notified by the Company to the Customer at or before the time the Customer's order is placed, or to sell the Goods to any person if the Customer knows or has reason to believe that that person intends to resell the Goods in any such country. The Customer agrees to abide by any governmental regulations of any relevant country which may exist preventing or restricting the export of the Goods to certain countries and to indemnify the Company against any actions costs demands or expenses resulting from any failure by the Customer to do so.

11.3 The Contract may be subject to United States and European Union laws and requirements to obtain a validated export licence as well as to similar laws in other applicable jurisdictions. If applicable the Company shall file for the export licence only after appropriate documentation for the licence application has been provided by the Customer, within a reasonable time after order acceptance. If an export licence is not granted or is revoked by the appropriate authorities, the Contract may be cancelled by the Company without liability.

11.4 In the case of Export contracts:

- 11.4.1 the provisions of this clause 11 shall (subject to any special terms agreed in writing between the Customer and the Company) apply notwithstanding any other provision of these Conditions.
- 11.4.2 the Customer shall be responsible for complying with any legislation or regulations governing the importation of the Goods into the country of destination and for the payment of any duties on them.
- 11.4.3 payment of all amounts due to the Company shall be made by irrevocable confirmed letter of credit payable in Germany subject to UCP (Uniform Customs and Practice for documentary credits – current revision) opened by the Customer at the Customer's expense in favour of the Company and confirmed by a recognised German Clearing Bank acceptable to the Company negotiable at sight against documents valid 90 days.
- 11.4.4 the United Nations Convention on Contracts for the International Sale of Goods shall apply to Contracts made under these Conditions to the extent that they are not inconsistent with these provisions. In the case of any conflict these Conditions shall prevail.

#### 12. GENERAL

12.1 The Company may perform any of its obligations or exercise any of its rights under the Contract, through any associated companies, agents or sub-contractors appointed by it in its absolute discretion for the purpose.

12.2 Any notice to be given by either party to the other under these Conditions shall be in Writing.

12.3 Service of notices may be by hand, pre-paid special delivery or recorded delivery post, fax or email (with written confirmation of fax or email signed by an authorised representative posted or delivered the same day). Service is deemed effected: by hand at the time of delivery; by inland first class post on the second day after posting; by fax at the time of dispatch provided confirmation of receipt from the machine of the other party is received and by email within 12 hours provided that within that time no notice of delivery failure has been received.. Service, or confirmation of service by post to persons overseas must be by air-mail post, and is deemed effected on the fourth day after posting. Failure to confirm service of any notice sent by fax will render the notice invalid.

12.4 No waiver by the Company of any breach of or default under the Contract by the Customer shall be considered as a waiver of any subsequent breach of the same or any other provision. Any waiver shall in no way affect the other terms of the Contract. Failure or delay by the Company in enforcing or partially enforcing any provision of the Contract shall not be construed as a waiver of any of its rights under the Contract.

12.5 The Company may assign the Contract or any part of it to any person, firm or company. The Customer shall not be entitled to assign the Contract or any part of it without the prior written consent of the Company.

12.6 Each right or remedy of the Company under the Contract is without prejudice to any other right or remedy of the Company whether under the Contract or not.

12.7 If any provision of the Contract is found by any court, tribunal or administrative body of competent jurisdiction to be wholly or partly illegal, invalid, void, voidable, unenforceable or unreasonable it shall to the extent of such illegality, invalidity, voidness, voidability, unenforceability or unreasonableness be deemed severable and the remaining provisions of the Contract and the remainder of such provision shall continue in full force and effect.

12.8 The parties to the Contract do not intend that any term of the Contract shall be enforceable by virtue of the Contracts (Rights of Third Parties) Act 1999 by any person that is not a party to it.

12.9 The Contract shall be governed by the laws of Germany, subject only to the Company's right to bring a claim to the German courts.

12.10 Subject only to the Company's right to bring a claim in the German courts, any disputes connected with this contract or the single business actions performed under its conditions shall be ruled by German Law excluding the Convention on the International Sales of Goods (CISG). Place of jurisdiction is Heilbronn/Germany.

12.10.1 The number of arbitrators shall be one.

12.10.2 The language to be used in the arbitral proceedings shall be German. In the event that the Company's option is deemed to be ineffective for any reason, the language to be used in the arbitral proceedings shall be English.

12.11 The Company reserves the right to refer any dispute arising out of or in connection with this contract, including any question regarding its existence, validity or termination that has not already been referred to arbitration, to the German courts. Once the Company has exercised this option, by issuing a claim in any German court, it shall thereafter not be possible for either party to refer the same dispute to arbitration.

12.12 In case of any conflict the English language version of these Conditions shall prevail.



**MBS AG**

'Sulzbach Messwandler'

Eisbachstr. 51

74429 Sulzbach-Laufen

Germany

Telefon: +49 7976 9851 - 0

Telefax: +49 7976 9851 - 90

E-Mail: [info@mbs-ag.com](mailto:info@mbs-ag.com)

Web: [www.mbs-ag.com](http://www.mbs-ag.com)

**Works 2:**

Eisbachstraße 33

74429 Sulzbach-Laufen

**Works 3:**

Eugen-Hahn-Straße 35

73565 Spraitbach

